

PCB connector for THR

970-THR(-DS)

Screw connection

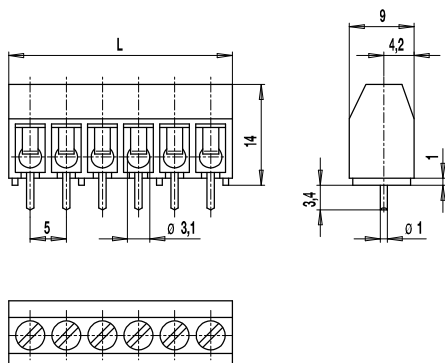

PCB Layout

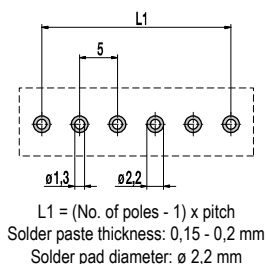

The products based on our established 970 series have been designed for the soldering process in Through-Hole-Reflow technology. The soldering paste is applied to the plated through holes and the pins are placed in the circuit board and soldered by a reflow oven. The terminal mouldings are made of heat-resistant material. The stand-offs on the base ensures there is enough room for the soldering paste and facilitates good heat circulation for optimum soldering and enables the soldering joint to be visually inspected. The solder pin projects very slightly with a circuit board thickness of 1,6 mm and creates a solder point on both sides and thus guarantees a secure mounting. The position of the solder pins enables an equally minimal allocation area on the circuit board as with wave soldering. This PCB connector with a pitch of 5 mm is for a conductor cross sections of 2,5 mm² and available in 2 to 12 pole lengths, with or without wire protector. This connector is also available with enlarged clamping size.

Part Numbers

No. of poles	970-THR	970-THR-DS	Length	Pcs
2	10.879.202	20.879.202	11,00	250
3	10.879.203	20.879.203	16,00	250
4	10.879.204	20.879.204	21,00	200
5	10.879.205	20.879.205	26,00	100
6	10.879.206	20.879.206	31,00	100
8	10.879.208	20.879.208	41,00	100
10	10.879.210	20.879.210	51,00	100
12	10.879.212	20.879.212	61,00	100

further number of poles on request

General Information

Pitch	5 mm
No. of poles	2 - 12

Technical Data

Clamping Range	<i>solid / flexible / AWG</i>		
	<i>without wire protector</i> 1 - 6 mm ² / 1 - 2,5 mm ² / 16 - 12 AWG		
	<i>with wire protector</i> 0,75 - 4 mm ² / 0,75 - 2,5 mm ² / 18 - 12 AWG		
Rated Cross Section	2,5 mm ²		
Wire Stripping Length	6,5 mm \pm 0,5 mm		
Overvoltage Category	III	III	II
Pollution Severity Level	3	2	2
Rated Voltage	250 V	320 V	630 V
Rated Impulse Voltage	4 kV	4 kV	4 kV
Rated Insulation Voltage	250 V acc. to EN 60998-1		
Rated Current	24 A		
Soldering process	Wave solder & reflow solder		
Hole in PCB	\varnothing 1,3 mm		
PCB thickness	Wave solder max. 1,6 mm; reflow solder 1,6 - 3,2 mm		
Torque	0,5 Nm		

Material

Moulding	PA HT, black, V-0
Comparative Tracking Index	CTI \geq 600
Insulating Group	I
Temperature Range	-40°C up to 150°C; reflow solder temperature (Peak) max. 260°C (15-30 s)
Terminal body	Tin plated brass
Screw	M3; zinc plated steel, blue passivated
Solder pin	\varnothing 1 mm; tin plated copper
Wire protector	Tin plated tin bronze

Approvals

	Current	Voltage	Group	AWG	Nm
	20	300	B	22-12 [1]	0,51
	10	300	D	22-12 [1]	0,51
	20	300	B	26 - 12	0,51
	10	300	D, E	26 - 12	0,51

Options / Accessories

- Consecutive numbering / Special marking according to drawing
- Self-adhesive marking strip BST-5,00 [2]
- Other P.C. pin lengths on request

Part Numbers: Tape-on-Reel

No. of poles	970-THR	970-THR-DS	Tape Width	Tape Height	Pcs
2		20.879.202.A00	32 mm	18,8 mm	225
4		20.879.204.A00	32 mm	18,8 mm	225

further number of poles on request

- [1] No. 26 AWG min for factory-wiring only
 [2] To be fitted after reflow soldering process