

Energy
saving by Pilz



Drive technology PMC

pilz
the spirit of safety

- ▶ Motion control systems ▶ Servo amplifiers ▶ Motors
- ▶ Safe motion monitoring on vertical axes





Pilz is your solution supplier for all automation tasks. Including standard control functions. Pilz developments protect man, machine and the environment.

Pilz has a tradition as a family-run company stretching back over 60 years. Real proximity to customers is visible in all areas, instilling confidence through individual consultation, total flexibility and reliable service. Worldwide, round the clock, in 31 subsidiaries and branches, as well as 15 sales partners on every continent.

More than 1 800 staff, each one of them an ambassador for safety, make sure that your company's most valuable asset – your staff – can work safely and free from injury.



Further information:
www.pilz.com +
Webcode 0837

S
ems

ical
ergy-efficient
and environmentally-
lications

SERVICES

Consulting, engineering
and training

Economical

Count on efficient production and
the security of investment provided
by our system solutions

pilz
the spirit of safety

Automation
solutions from Pilz –
at home in every
industry.





Pilz drive technology – Safe, open,
energy efficient, productive

► Individual solutions

As market and technology leader, Pilz offers overall solutions for safety and automation.

Part of these solutions is Pilz drive technology. Pilz motion control (PMC) provides overall solutions for automating your machine. From control systems to servo amplifiers, right up to servo motors.

At Pilz you can buy everything from one source. Embedded within the respective system environment, including all safety aspects plus the relevant accessories.

The focus is always on your application. Whether it's individual components or the complete solution: with Pilz drive technology, there are no limits.

Contents

Automation: complete and simple!	6	Software: Pilz Motion Control Tools	38
Product area: Drive technology PMC	8	Product group: Motors	40
► Applications and industries	10	► Selection guide	40
		► Technical details PMCTendo SZ	42
Product group:			
Motion control systems	12	Safe motion monitoring on vertical axes	48
► Selection guide	12	► Applications on safe vertical axes	48
► Product range PMCprimo DriveP	14	► Protective measures on vertical axes	50
► Technical details PMCprimo DriveP	16	► Safe motion product range – PMCprotego DS	52
► Technical details PMCprimo Drive3	18	► Safety relay product range PNOZ s50	54
► Technical details PMCprimo 16+	20		
		Accessories for drive technology PMC	56
Product group: Servo amplifier	22		
► Selection guide	22	Energy efficiency: Drive technology PMC	60
► Technical details PMCprotego D	24		
► Technical details PMCTendo DD5	26	Safety services, consulting, engineering and training	64
Product range:			
Safety card PMCprotego S	28	Index	65
► Technical details PMCprotego S	30		
► Risk assessment PMCprotego S	32		



Scan the QR code with your smartphone to see the 3D animation for drive technology PMC.



Automation solutions for your plant and machinery – complete and simple.

Pilz offers you solutions for complete automation. From sensor technology to control and drive technology – with safety and automation included. On all components and systems, simple commissioning, simple handling

and simple diagnostics play an important role!

Profit from flexible automation solutions for small machines or even large, networked plants. Regardless of whether you want to standardise your safety, implement safety and automation in the periphery or are looking for the solution for complete automation.

Pilz solutions are embedded into the relevant system environment – whether a new structure or a retrofit – and open for a variety of interfaces and functionalities.

The perfect combination:

Control technology enables numerous application options, including monitoring of electrical



Programming IEC 61131-3

Rapid Installation

Automation: complete and simple!

- ▶ Full diagnostic options for reduced machine downtimes
- ▶ Open communication for high flexibility
- ▶ Innovative software solutions for easy configuration and programming
- ▶ High scalability for individual solutions
- ▶ One system for safety and automation



and functional safety, through to complete machine control.

In combination with the various control systems, safe **sensors** and **decentralised modules** guarantee the efficient use of plant and machinery in compliance with standards. Ready-to-install systems and universally compatible solutions offer high potential savings.

In the area of **drive technology**, the offer includes drive-integrated safety functions, safe logic functions and the connection of visualisation, sensor and actuator technology.

Your plant or machinery are completed with **operator and graphics devices** from Pilz.

Design, programming, configuration, commissioning and diagnostics can be achieved quickly and simply using Pilz **automation software**.

Pilz offers scalable solutions to suit each requirement – from sensor technology to control and drive technology.

► Pilz drive technology – Safe, energy efficient, open, productive



Pilz Motion Control provides overall, energy-efficient solutions for your machine automation. The portfolio comprises both individual components and complete solutions: from motion control systems and servo amplifiers to servo motors, including all safety aspects. Pilz drive technology is embedded into the relevant system environment – whether a new structure or a retrofit – and is open for a variety of interfaces and functionalities.

Expert advice on all issues relating to your drive

From planning to implementation, Pilz is right there beside you as your competent partner. The range of services extends from risk assessment to drive configuration, hardware and software design through to commissioning. Regular safety checks and a comprehensive range of training measures complete our range.

Your benefits at a glance

- Safe: up to PL e of EN ISO 13849-1 for each piece of feedback
- Energy efficient: high energy savings thanks to efficient servo technology
- Open: highly flexible because various fieldbus/ feedback systems and functionalities can be used
- Productive: short cycle times enable high performance
- Simple parameter setting and diagnostics thanks to intuitive commissioning tools

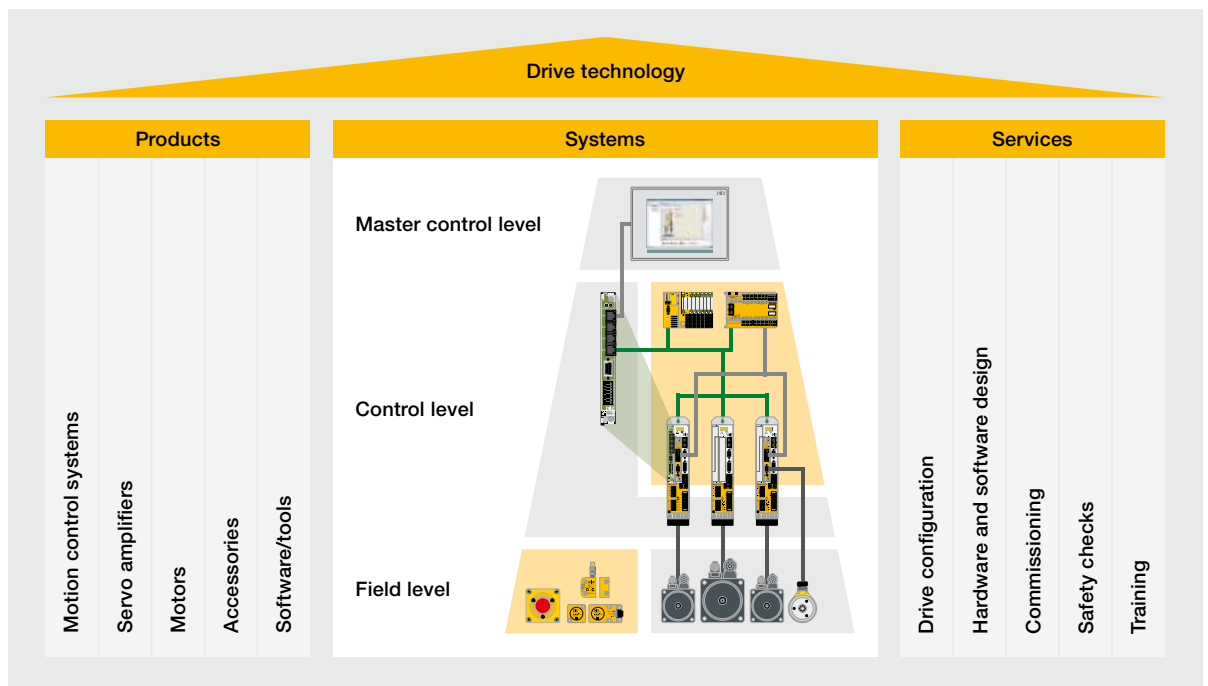

Pilz drive technology: Products, services, systems – the one stop shop.

Minimise downtimes

Thanks to the PVIS diagnostic concept, system messages from the PMC control systems and servo amplifiers can be displayed in plain text. Remedy messages are displayed for each event. PVIS significantly reduces downtimes in the case of a fault. Thanks to pre-defined messages, even project configuration is child's play.

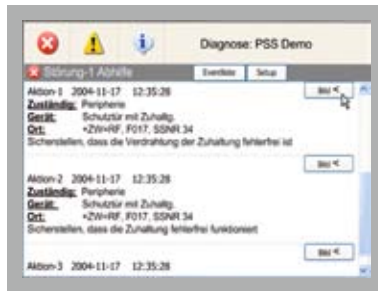

Your benefits at a glance





- ▶ For simple to high end applications
- ▶ Solution is always expandable thanks to the modular design
- ▶ Fast to commission and simple to service thanks to universal programming in accordance with IEC 61131-3
- ▶ Complete automation solution or individual components – depending on your requirement
- ▶ Customised solutions incorporating all safety aspects
- ▶ Individual advice and customer care



Open and flexible connection

Safe drive technology – Safe Motion – is open for connection to all standard PLC and motion control systems. Benefit from the high flexibility of our solutions, e.g. if only part of the machine is renovated during a retrofit.

Overview of control systems and servo amplifiers

	Control systems			Servo amplifiers	
	Controller-based	Safe drive-based	Drive-based		
	 PMCprimo 16+	 PMCprimo DriveP	 PMCprimo Drive3	 PMctendo DD5	 PMCprotego DS
Programming Soft PLC in accordance with IEC 61131-3	◆	◆	◆		
Motion control	◆	◆	◆		
Servo amplifiers		◆	◆	◆	◆
Safe Torque Off		◆	◆	◆	◆
Additional safety functions		◆			◆

Keep up-to-date on drive technology PMC:



Webcode 5261

Online information at www.pilz.com

► For a wide range of applications

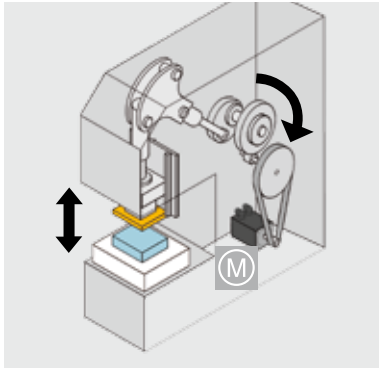

Servo press

Presses with servo drive increase the output rate compared with conventional presses and provide maximum flexibility. The safe motion solution is suitable for implementation of the necessary safety level PL e of EN ISO 13849-1 and SIL CL 3 of EN/IEC 62061. Functions such as “Safely Limited Speed” in setup mode, “Safe Direction” during the light grids' muting phase and “Safe Brake Control” enable operators to work safely within the danger zone.

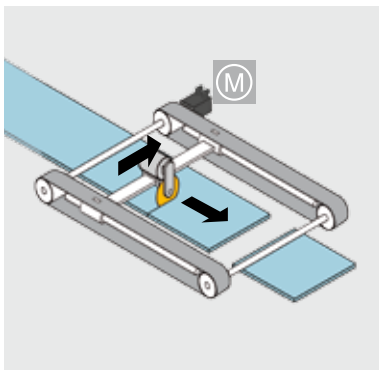

Flying saw

When cutting endless material such as wood or sheet metal for example, the flying saw moves synchronously with the material to be cut, so that the machining process does not need to be stopped. Once machining is finished, the cycle is restarted. If you add a safety aspect to this classic motion control function, the flying saw can be set up without risk at “Safely Reduced Speed”, for example.

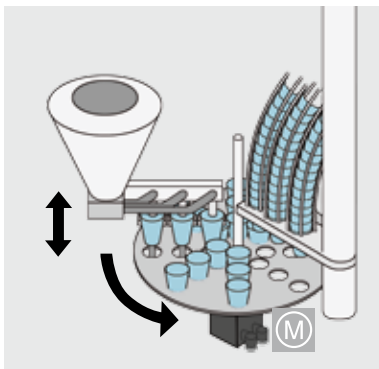

Filling

When filling liquid or paste products, axis movements are precisely co-ordinated. Motion sequences for setting dosing plungers and lifters can be set individually. Filling is so accurate that no material is spilt. The packaging size and associated fill volume can be modified. Recipes can also be incorporated for different fillings or weights. With Pilz motion control, the challenges of filling operations are like child's play.



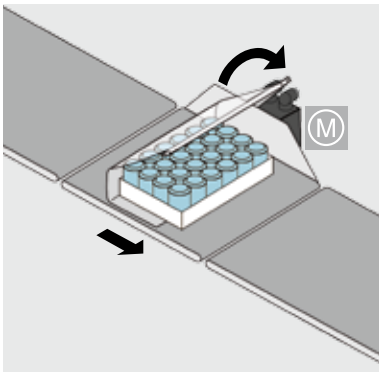

Wraparound

The wraparound application places high demands on precision and on the synchronicity of axis movements. The position of the product to be wrapped is identified first, then the film is unwound and the imprint is positioned precisely in the designated place. Plus the film is cut before the product is fully wrapped. An intelligent motion control system is a prerequisite for synchronising the relevant axes.

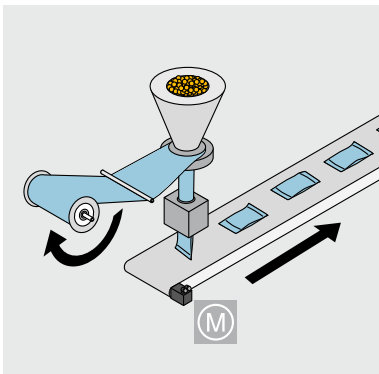

Flow wrapping machine

When flow wrap bags are filled, various motion sequences are synchronised, such as unwinding the flow wrap bags, packing the product and transporting it to the end packing station. The motion control system with its functions and reaction times has considerable influence on process quality. Fast inputs for print mark sensors enable a rapid reaction to print marks on the overwrap film and the necessary adjustment of the motion curves.

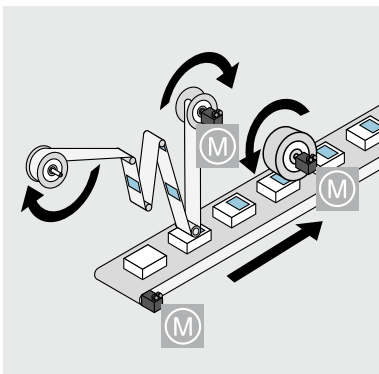

Labelling

The unwind shaft and conveyor must be synchronised in order to position labels precisely. A sensor detects the label and sends a signal to the motion control system, in order to compensate for the tolerances that occur by adapting the motion paths. Short cycle times and fast digital inputs on the motion control system guarantee optimum synchronisation of the relevant axes and precision label placement.



► Motion control systems PMCprimo®

Control systems PMCprimo 16+ and PMCprimo Drive are used for all types of motion and control functions. They consist of PLC and motion technology. They perform the automation within a plant, including management of all the movements for a large number of physically separate servo axes.

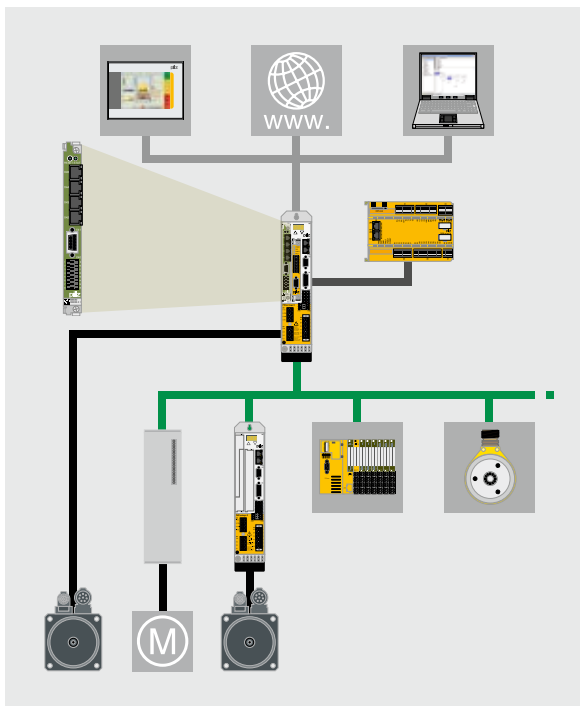

Safe drive-based control system PMCprimo DriveP.

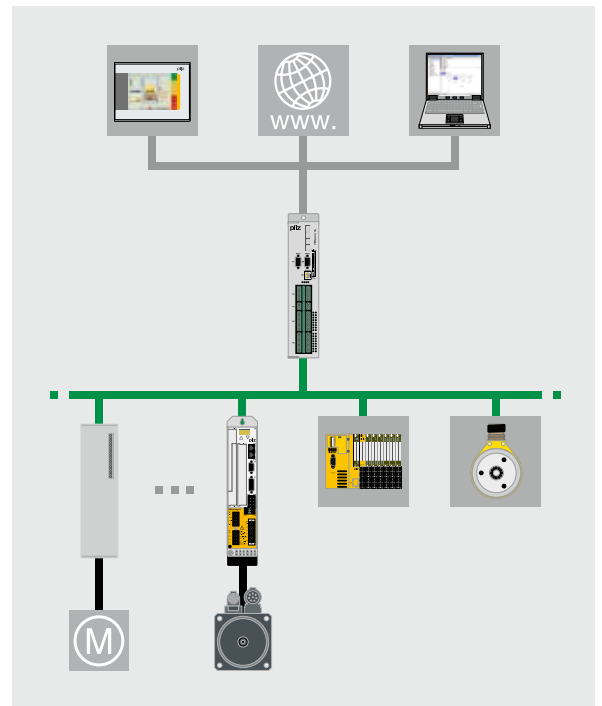

Open, controller-based control system PMCprimo 16+.

Universal programming under IEC 61131-3 in one project, covering standard PLC to motion control functionality, provides the basis for a wide range of functions:

- (Shock-free) positioning
- Virtual main shaft
- Electrical gearbox
- Cam mechanism
- Integral "flexible cam"
- Register control
- Web tension control
- PLC functionality
- Linear and circular interpolation
- Electronic camshaft
- Fast inputs to detect print marks

Selection guide – Motion control systems PMCprimo

Type	Bus systems
PMCprimo DriveP	PROFIBUS-DP Slave, CANopen; SafetyNET p RTFL in preparation ¹⁾
PMCprimo Drive3 ³⁾	Modbus, PROFIBUS-DP Small Slave, CANopen
PMCprimo 16+	Modbus, PROFIBUS-DP Small Slave, PROFIBUS-DP Master, PROFIBUS-DP Slave, CANopen

Combining economy with safety

A compact and cost-effective solution is available with the drive-based control systems PMCprimo Drive. From the second axis onwards, the servo amplifiers are simply connected to the drive bus. This reduces the space requirement in the control cabinet, plus you have an economical solution for your application. The servo amplifiers PM Ctendo DD5 have the "Safe Torque Off" (STO) function and are connected to the drive-based control system PMCprimo Drive3.

All-in-one motion control

The safe drive-based control system PMCprimo DriveP is suitable when the demand is for control tasks with a particularly high performance level. Incorporate the motion control card PMCprimo C into the servo amplifier PMCprotego D and the result is an extremely compact, high-performance system. Compared with the PMCprimo Drive3, the number of axes is almost doubled, i.e. up to 16, at the same cycle time. As an option, safety functions can also be expanded using the safety card PMCprotego S.

Flexibility through openness

PMCprimo 16+ offers a flexible solution because the control system can be used centrally or as part of a network. The controller-based hardware platform provides the basis for an open system. The controller is cascadable, so PMCprimo 16+ can also be used for large-scale applications.

Your benefits at a glance

- ▶ Solution is always expandable thanks to the modular design
- ▶ Two hardware platforms, providing the optimum hardware basis for each application
- ▶ Combination of PLC and power element (PMCprimo Drive) provides an economical solution
- ▶ Open for house standards and customer requirements thanks to a wide range of interfaces
- ▶ Fast to commission and simple to service thanks to universal programming in accordance with IEC 61131-3
- ▶ Suitable for simple to complex applications

Number of axes	Hardware platform	Safety functions
1 to 16	Safe drive-based	(SLS, SDI, SBT, SBC, SOS, SS1, SS2, SSR, STO, SLI, SLP) ²⁾
1 to 9	Drive-based	STO
1 to > 100 ⁴⁾	Controller-based	-

¹⁾ Additional bus systems on request

²⁾ When using PMCprotego S

³⁾ PMCprimo Drive2 and PM Ctendo DD4 are available on request

⁴⁾ Networking of several control systems PMCprimo 16+

Keep up-to-date on control systems PMCprimo:

 Webcode 5531

Online information at www.pilz.com

► Control system PMCprimo DriveP: All-in-one mo

The motion control system PMCprimo DriveP can resolve all control tasks relating to your motion control application at the highest performance level. Plug the motion control card PMCprimo C into the servo amplifier PMCprotego D and the result is an extremely compact, high-performance motion control system.

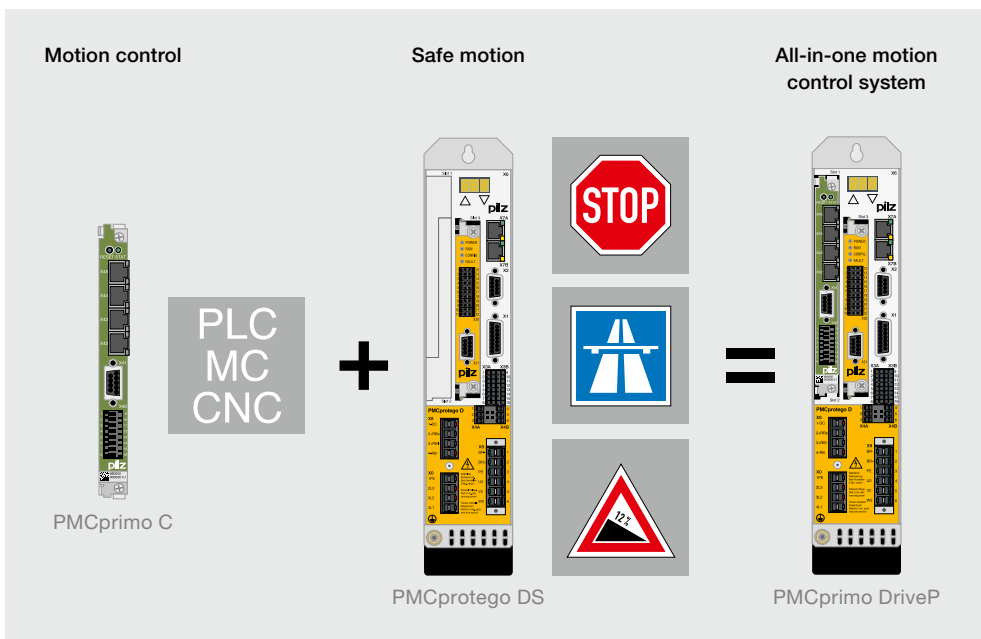

Compact solution

Due to the compact dimensions, motion control, PLC and safety functions can be combined in one unit – making it the most compact solution on the market. Clear, user-friendly software tools simplify commissioning of the motion control system and can save time through clear project documentation.

Technology leader

The motion control system uses the Intel x86 Atom processor, enabling short cycle times plus high performance, as well as increasing the process quality of your application. This processor is the very latest available on the market, guaranteeing your investment and assuring long-term availability of spares.

All-in-one with safe motion

The servo amplifier is used in safety-related applications up to PL e of EN ISO 13849-1 and SIL 3 of EN/IEC 62061. The safety card PMCprotego S can also be used as an option to expand the PMCprotego D with drive-integrated safety functions in accordance with EN 61800-5-2 – thus completing the all-in-one motion control system from Pilz. Further information on Pilz safe motion is available from page 28.

Fieldbus communication lightens the load on the processor thanks to the FPGA chip, enabling the implementation of more complex plants with multiple axes. The integration of multiple communication stacks reduces the number of product types as well as storage costs. High performance communication between processor and FPGA also reduces the system reaction times.



tion control

The high processing power of the motion control system PMCprimo DriveP also enables low process tolerances. Thanks to the parallel operation of two CANopen networks, short cycle times with up to 16 axes can be achieved. This increases the process quality due to shorter bus cycle times.

Economical due to additional inputs and outputs

The inputs and outputs on the servo amplifier can be evaluated and controlled by the servo amplifier PMCprimo C as well as the six digital input and outputs on the motion control system. The additional inputs and outputs offer an economical solution and provide the highest flexibility for your application. The wide range of interfaces also offer openness to suit individual requirements. The use of fast inputs on the motion control card PMCprimo C in the servo amplifier also enables print mark detection on each axis. As a result, faster system reaction times are achieved, enabling more axes and therefore larger machines and systems to be controlled at the same time.

All the configuration data is stored on the SD memory card, so no additional components such as PC, software or cables are required when exchanging units or expanding the system. The memory card can simply be inserted into the new device.

Your benefits at a glance

- ▶ Short cycle times and high performance
- ▶ Long availability through use of the latest Intel processors
- ▶ Higher performance thanks to shorter scan times:
- ▶ More space in the control cabinet thanks to the compact, drive-integrated solution
- ▶ Simple, fast commissioning
- ▶ High productivity thanks to the short reaction times
- ▶ Fast digital inputs (5 µs) enable higher material speed
- ▶ Fast, user-friendly introduction and project documentation as a result of clear software tools

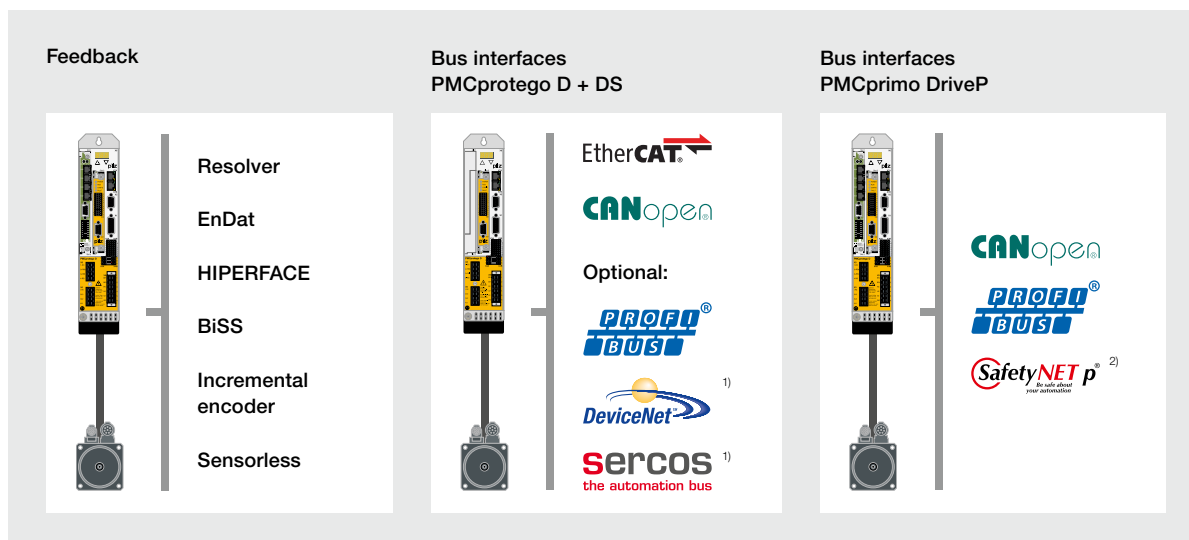

¹⁾ On request ²⁾ SafetyNET p RTFL in preparation

► Technical details – PMCprimo DriveP

Safe drive-based motion control system PMCprimo DriveP



PMCprimo DriveP

Technical details		Options
<p>Motion control card PMCprimo C</p> <ul style="list-style-type: none"> ▶ CPU 0.6 GHz ▶ 1 Ethernet port for Modbus TCP/IP (communication/programming) ▶ 2 ports for SafetyNET p (linear structure) ▶ 2 interfaces <ul style="list-style-type: none"> - CANopen/CANopen - CANopen/PROFIBUS-DP-S ▶ 6 digital inputs and outputs ▶ Ability to use I/O on the servo amplifier ▶ Encoder input incremental/SSI ▶ Memory: remanent (512 KB), RAM (128 MB), mass storage (512 MB) ▶ Up to 30 subscribers available ▶ Freely definable synchronisation between axes and encoder <ul style="list-style-type: none"> - Electronic gearing (linear/non-linear) - Master/Slave mode ▶ Print mark detection ▶ Freely programmable ▶ Unlimited number of target positions 	<p>Servo amplifier PMCprotego D</p> <ul style="list-style-type: none"> ▶ Position controller with max. 200 motion tasks ▶ Electronic gearing ▶ Master/Slave mode ▶ Encoder emulation ▶ Universal voltage range ▶ Intermediate circuits can be connected in parallel ▶ Encoder: up to 2 encoder inputs, 3 encoder inputs with additional card, 1 encoder output if one encoder input is omitted ▶ Digital inputs: 2 x 5 µs, 2 x 250 µs, 2 x STO Enable ▶ Analogue inputs: 2 x 16 Bit, ±10 V ▶ CANopen profiles (DS301, DS402) ▶ Serial interface RS 232 ▶ Read/write device for SD card (SD Memory Card 512 MB, order number: 313 100) ▶ Safe Torque Off (STO) up to SIL 3 of EN/IEC 62061, PL e of EN ISO 13849-1 ▶ Integrated mains filter ▶ Internal brake resistor (size 01 ... 24) ▶ Protection type: IP20 ▶ Vertical mounting position ▶ CE certification and UL approval ▶ TÜV-approved safety 	<ul style="list-style-type: none"> ▶ Dynamic curve calculation ▶ Soft PLC in accordance with IEC 61131-3 ▶ Path interpolation ▶ As an option, slot 3 of the servo amplifier PMCprotego D can be configured with: <ul style="list-style-type: none"> - PMCprotego S1-2 - PMCprotego S2-2 - PosI/O with fast bidirectional 5 V I/O for position encoder emulation (ROD or SSI) or RS 485 signals for encoder control or Master/Slave - PosI/O-AIO for PosI/O functions; analogue input ±10 V, 16 Bit; analogue output ±10 V, 16 Bit

Type code

Type/Order number	Mains voltage
PMCprimo DriveP: __/_/___/_/_/_/	208 ... 480 VAC

Current A	Size	Slot configuration									
1.5	01										
3	03										
6	06										
12	12 ¹⁾										
24	24 ¹⁾										
48	48										
72	72										

		Hardware: PMCprimo C	AA0	AA1	AA2	AAC	AAD	AB0	AB1	AB2	ABC	ABD
Slot 1/2	A	CPU 0.6 GHz										
	Hardware: Bus system											
Slot 1	A	CANopen/CANopen										
	B	CANopen/PROFIBUS-DP-S										
Slot 3	0	None										
	1	PosI/O ³⁾										
	2	PosI/O-AIO ⁴⁾										
	C	PMCprotego S1-2										
	B	PMCprotego S2-2										

Standard bus systems: CANopen

We reserve the right to amend technical details

Features	Unit	Size (other sizes in preparation)									
		01	03	06	12	12P	24	24P	48	72	
Nominal data											
Mains voltage (power)	VAC	3 x 208 ... 3 x 480 V ±10 %									
Frequency range	Hz	50 ... 60									
Max. motor voltage	VAC	Mains voltage less 4 V					Mains voltage less 6 V				
Continuous output current (at 400 VAC)	A _{eff}	1.5	3	6	12		24		48	72	
Peak output current (max. 2 s)	A _{eff}	4.5	9	18	24	30	48	72	96	140	
Peak output current (max. 5 s)	A _{eff}	3	6	12	24	24	48		96	140	
Power consumption in S1 mode	kVA	1.1	2.2	4.5	9		18		35	50	
Output stage clock frequency at I _{rms}	kHz	8/16 (50% I _{rms})									
Supply voltage (electronics/with brake)	VDC	24 0 ... +15% (approx. 1 A/max. 3 A)							(approx. 2 A/ max. 5 A)		
Power dissipation at I _{rms}	W	40	70	100	160		330		635	1005	
Ballast circuit											
Internal brake resistor:											
Continuous output	W	50		75	100		200		-		
Max. peak output for max. 1 s	kW	15					23		-		
External brake resistor:											
Max. continuous output	Ω	33					23		15	10	
Max. continuous output	kW	0.3	1		1.5		4		6	6	
Max. peak output for max. 5 s	kW	4 ... 21					6 ... 30		16 ... 70	16 ... 70	
Environmental conditions											
Ventilation											
Ambient temperature	°C	Forced ventilation through built-in fans 0 ... +40 at rated power, +40 ... +55 with power derating 2.5%/K									
Rel. humidity during operation	%	85, non-condensing									
Storage temperature	°C	-25 ... +55									
Installation height	m above sea level	Up to 1000 at rated power, 1 000 ... 2500 with current reduction of around 1.5%/100 m									
Mechanics											
Weight	kg	4.4					5.5		13		
Dimensions (excl. connector)	Height	345					348		385		
	Width	70					100		190		
	Depth	243									



Further technical details in the installation manual

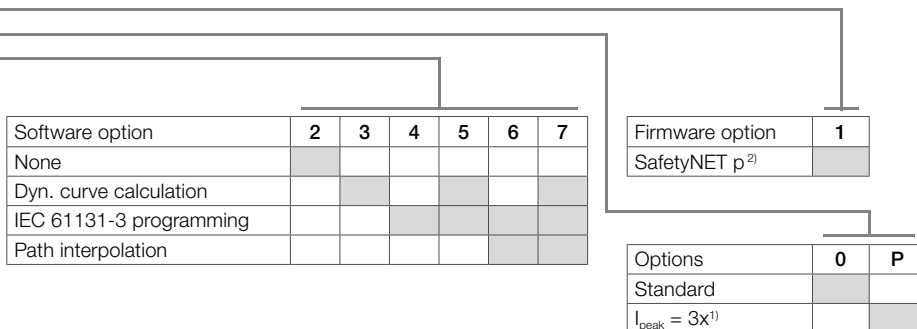

¹⁾ With increased peak output current as an option
²⁾ In preparation
³⁾ Expansion card without analogue outputs
⁴⁾ Expansion card with analogue inputs/outputs

► Technical details – PMCprimo Drive3

Drive-based motion control system PMCprimo Drive3



PMCprimo Drive3

Technical details

- ▶ 10 axes available
- ▶ 9 real axes
- ▶ Intermediate circuits can be connected in parallel
- ▶ 1 master encoder input
- ▶ Up to 10 virtual axes
- ▶ Cycle time in position control loop 1 ms
- ▶ 12 digital inputs and 8 digital outputs
- ▶ 2 analogue inputs
- ▶ Up to 8 electrical cams
- ▶ 8 KByte variable memory, battery-buffered in combination with expansion card
- ▶ 2 MByte Flash memory for user program
- ▶ Programming port RS 232
- ▶ CANopen
- ▶ Safe Torque Off (STO) up to SIL 2 of EN/IEC 62061, PL d of EN ISO 13849-1
- ▶ Integrated mains filter
- ▶ Internal brake resistor
- ▶ Serial interface RS 422 (Modbus)
- ▶ Auxiliary voltage 24 VDC
- ▶ Protection type: IP20
- ▶ Mounting position: vertical
- ▶ CE certification and UL approval

Options

- ▶ Fieldbuses:
 - PROFIBUS-DP Small Slave
 - CANopen (second CANopen)
- ▶ Internal cam editor
- ▶ Soft PLC programming in accordance with IEC 61131-3
- ▶ Expansion card with:
 - CANopen interface
 - CompactFlash, up to 1 GByte, plug-in
 - 8 KByte variable memory, battery-buffered
 - Ethernet up to 100 MBit/s

Type code

Type/Order number	Mains voltage
PMCprimo Drive3. _ _ / _ _ / _ _ / 0 / 0 /	_ _ _ _ VAC

	Current A	Size
230 V series	3	03
	6	06
	10	10
480 V series	1.5	01
	3	03
	6	06

Hardware option	11	21	23	25
None				
Expansion ⁴⁾				
PROFIBUS-DP-S ⁵⁾				

Standard bus systems:
CANopen, Modbus

Software option	2	3	4	5	6	7
None						
Dyn. curve calculation						
IEC 61131-3 programming						
Path interpolation						

We reserve the right to amend technical details

Features	Unit	Size					
		03	06	10	01	03	06
Nominal data							
Supply voltage (power)	VAC	1 x 110 ... 1 x 230 V ±10%, 3 x 110 ... 3 x 230 V ±10%			3 x 208 ... 3 x 480 V ±10%		
Frequency range	Hz	50 ... 60					
Max. motor voltage	VAC	Supply voltage less 5 V					
Continuous output current (at 3 x 230 V)	A _{eff}	3	6	10	-		
Peak output current (max. 5 s at 3 x 230 V)	A _{eff}	9	15	20	-		
Continuous output current (at 3 x 400 V)	A _{eff}	-			1.5	4	6
Peak output current (max. 5 s at 3 x 400 V)	A _{eff}	-			4.5	7.5	12
Power consumption in S1 mode	kVA	1.1	2.4	4	1.2	2.5	5
Output stage clock frequency at I _{rms}	kHz	8					
Supply voltage (electronics/with brake)	VDC	24 0 ... +15% (1.3 A/max. 2.8 A)					
Power dissipation at I _{rms}	W	35	60	90	40	60	90
Ballast circuit							
Internal brake resistor:							
Continuous output	W	20	50		20	50	
Max. peak output for max. 1 s	kW	3 ¹⁾			7 ²⁾		
External brake resistor:	Ω	66			91		
Max. continuous output	kW	0.3	1		0.3	1	
Max. peak output for max. 5 s	kW	3 ¹⁾			7 ²⁾		
Environmental conditions							
Ventilation ³⁾		Without	With		Without	With	
Ambient temperature	°C	0 ... +40 at rated power, +40 ... +55 with power derating 2.5%/K					
Rel. humidity during operation	%	85, non-condensing					
Storage temperature	°C	-25 ... +55					
Installation height	m above sea level	Up to 1000 at rated power, 1 000 ... 2 500 with current reduction of around 1.5%/100 m					
Mechanics							
Weight	kg	2.6			2.7		
Dimensions (excl. connector)	Height	279					
	Width	70					
	Depth	171					

Further technical details in the installation manual

230 V series	110 ... 230 VAC
480 V series	208 ... 480 VAC

¹⁾ at 230 V

²⁾ at 400 V

³⁾ Forced ventilation through built-in fans

⁴⁾ Expansion card with:

- ▶ CompactFlash slot
- ▶ Ethernet
- ▶ Second CANopen
- ▶ Real-time clock
- ▶ Battery-buffered RAM

⁵⁾ Modbus has no function when PROFIBUS-DP-S is activated

► Technical details – PMCprimo 16+

Controller-based motion control system PMCprimo 16+



PMCprimo 16+

Technical details

- ▶ 20 axes available
 - 18 real axes (+/-10 V)
 - and 2 virtual axes
- ▶ Each axis can be operated virtually
- ▶ 3 master encoder inputs
- ▶ Up to 20 virtual axes
- ▶ Modular, ability to network up to 60 PMCprimo 16+
- ▶ Cycle time in position control loop 1 ms
- ▶ 16 digital inputs and 16 digital outputs
- ▶ 2 analogue inputs and 2 analogue outputs
- ▶ Up to 16 electrical cams
- ▶ 128 KByte variable memory, battery-buffered
- ▶ 2 MByte Flash memory for user program
- ▶ Programming port RS 232
- ▶ 2 x CANopen
- ▶ Ethernet up to 100 MBit/s
- ▶ Serial interface RS 422 (Modbus)
- ▶ 2 x expansion slots for fieldbus systems
- ▶ Supply voltage: 24 VDC
- ▶ Protection type: IP20
- ▶ Mounting position: vertical

Options

- ▶ Fieldbuses:
 - PROFIBUS-DP (Master and Slave)
 - PROFIBUS-DP-S Small
 - CANopen (third and fourth CANopen)
- ▶ Internal cam editor
- ▶ Soft PLC programming in accordance with IEC 61131-3
- ▶ CompactFlash, up to 1 GByte, plug-in

Type code

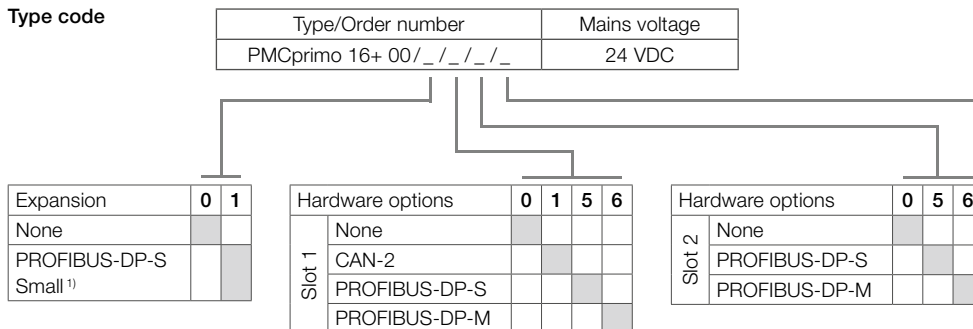

Standard bus systems: Ethernet, 2 x CANopen, Modbus
 Standard hardware: CompactFlash slot

We reserve the right to amend technical details

Features		Unit	Performance data
Nominal data			
CPU supply voltage		VDC	24
I/O supply voltage		VDC	24
Rotary encoder supply voltage		VDC	5 ... 24 (external feed)
CAN supply voltage			Internal
Power dissipation		W	Max. 16
Environmental conditions			
Ventilation			Natural convection
Ambient temperature		°C	0 ... +45
Rel. humidity during operation		%	0... 95, non-condensing
Storage temperature		°C	-25 ... +70, max. 20 K/hour variation
Storage humidity		%	Max. 95 rel. humidity, non-condensing
Pollution degree			2 in accordance with VDE 0100
Overtoltage category			II
Max. installation height		m above sea level	3000
Mechanics			
Dimensions (excl. connector)	Height	mm	317
	Width	mm	64
	Depth	mm	185

Further technical details in the installation manual

Software options	2	3	4	5	6	7
None						
Dyn. curve calculation						
IEC 61131-3 programming						
Path interpolation						



¹⁾ Modbus has no function when PROFIBUS-DP-S Small is activated

▶ Servo amplifiers PMCprotego D and PM Ctendo DD

Intelligent servo amplifiers from Pilz are used as drive controllers for the widest range of motor technologies. You can use it to operate all common types of motor, from servo motors to asynchronous and linear motors. Plus rotary direct drives, linear servo motors and applications with special motors. Take advantage of the benefits of these servo amplifiers: during design, control, application and operation.

These modern servo amplifiers do much more than drive the motor:

- ▶ Positioning
(driven via bus or inputs)
- ▶ Ability to store up to 200 motion tasks
- ▶ Ability to run small motion sequences
- ▶ Speed control
- ▶ Torque control
- ▶ Electric gear function

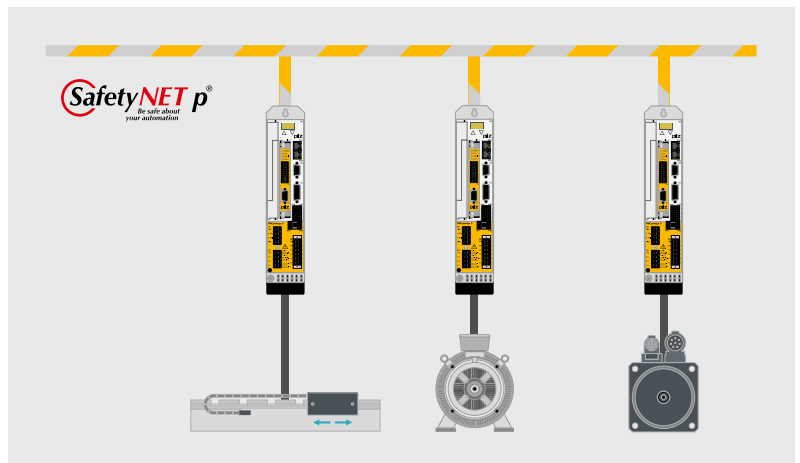

Servo amplifiers PMCprotegoD and PM CtendoDD can be used with the widest range of motor technologies.

Universal application

The servo amplifiers PMCprotego D and PM Ctendo DD are designed for stand alone operation. Even the basic version provides all the functions necessary to operate a brushless motor in asynchronous or synchronous technology. More than 20 different feedback systems can be connected directly for operating the widest range of motor technologies. The servo amplifiers are compatible with a wide range of control systems thanks to the optional bus cards.

Selection guide – Servo amplifiers PMCprotego D and PM Ctendo DD

Type	Rated current	Peak current (2 s)	Power supply
PMCprotego D	1.5 ... 72 A	4.5 ... 140 A (up to max. 3x rated current)	208 ... 480 VAC
PM Ctendo DD5 ¹⁾	3.0 ... 10 A 1.5 ... 6 A	9.0 ... 20 A 4.5 ... 12 A	110 ... 230 VAC 208 ... 480 VAC

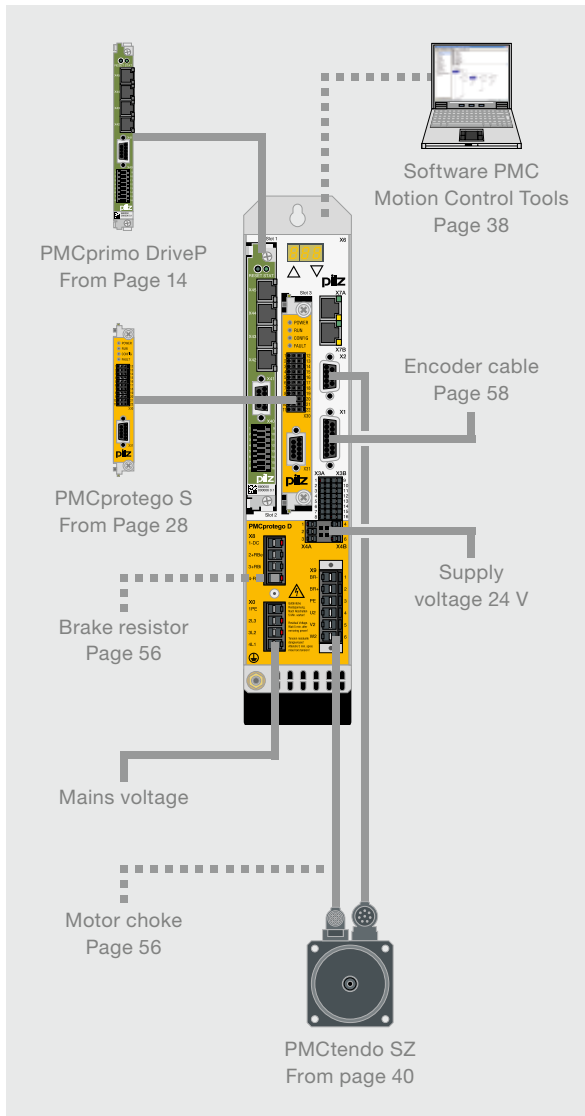

Selection guide PMcprtego D

Open for option cards

Expansion cards for almost all relevant fieldbus systems or PLCs can simply be plugged into the option slot on the servo amplifier. As a result, all amplifier functions can be accessed directly. The intermediate circuit connection with intelligent ballast circuit enables an optimum energy balance. So frequently there is no need for external brake resistors, even on critical axes.

Safe motion and motion control can be integrated

All servo amplifiers include the “Safe Torque Off” function, even in their basic configuration. The safety card PMcprtego S is used for additional safety functions (from page 28).

The motion control system PMcprimo C can also be integrated into the servo amplifier as a plug-in card, creating the all-in-one motion control solution from Pilz (from page 14).

PMctendo DD

The compact series of the servo amplifier PMctendo DD includes the “Safe Torque Off” function. Additional safe drive functions are implemented externally.

Keep up-to-date on:
 ▶ SafetyNET p

Webcode 6548

▶ Servo amplifiers PMcprtego D and PMctendo DD

Webcode 5270

Online information at www.pilz.com

Current loop update rate	Size	Safe Torque Off	Additional safe drive functions	
			External solution	Drive-integrated solution
62.5 μs (31.25 μs) ²⁾	Standard	◆	◆	◆
62.5 μs (31.25 μs) ²⁾	Compact	◆	◆	

¹⁾ PMctendo DD4 and PMcprimo Drive2 are available on request ²⁾ Parameters can be set

► Technical details – PMCprotego D

Servo amplifier PMCprotego D



PMCprotego D
(size 01 ... 12)



PMCprotego D
(size 48/72)

Technical details

- ▶ Position controller with max. 200 motion tasks
- ▶ Electronic gearing
- ▶ Master-Slave mode
- ▶ Encoder emulation
- ▶ Universal voltage range
- ▶ Intermediate circuits can be connected in parallel
- ▶ 2 encoder inputs
- ▶ 1 encoder output
- ▶ 2 digital inputs, STO Enable
- ▶ 2 digital inputs, 5 µs
- ▶ 2 digital inputs, 250 µs
- ▶ 2 digital inputs or outputs, 250 µs
- ▶ 2 analogue inputs ±10 V, 16 Bit
- ▶ CANopen
 - DS301 communication profile
 - DS402 drive profile
- ▶ Ethernet-based bus communication EtherCAT
- ▶ Serial interface RS 232
- ▶ Read/write device for SD card
(SD Memory Card 512 MB, order number: 313100)
- ▶ Safe Torque Off (STO) up to
SIL 3 of EN/IEC 62061,
PL e of EN ISO 13849-1
- ▶ Integrated mains filter
- ▶ Internal brake resistor (size 01 ... 24)
- ▶ Protection type: IP20
- ▶ Mounting position: vertical
- ▶ CE certification and UL approval
- ▶ TÜV-approved safety

Options

- ▶ As an option, slot 1 can be configured with:
 - DI I/O expansion card
with 14 inputs and 8 outputs
 - Fieldbus: PROFIBUS-DP-S
- ▶ As an option, slot 2 can be configured with:
 - Posl/O with fast bidirectional 5 V I/O
for position encoder emulation (ROD or SSI)
or RS 485 signals for encoder control
or Master/Slave
 - Posl/O monitor for Posl/O-AIO functions;
2 analogue inputs ±10 V, 16 Bit;
2 analogue outputs ±10 V, 16 Bit
- ▶ As an option, slot 3 can be configured
with safety card:
 - PMCprotego S1-2
 - PMCprotego S2-2
 - Posl/O with fast bidirectional 5 V I/O
for position encoder emulation (ROD or SSI)
or RS 485 signals for encoder control
or Master/Slave
 - Posl/O monitor for Posl/O functions;
analogue input ±10 V, 16 Bit;
analogue output ±10 V, 16 Bit

Type code

Type/Order number	Mains voltage
PMCprotego D. _ _ / _ _ _ / 0 / _ / _ /	208 ... 480 VAC

Current A	Size
1.5	01
3	03
6	06
12	12 ¹⁾
24	24 ¹⁾
48	48
72	72

Hardware option		000	100	200	101	201	102	202	10C	20C	10D	20D	001	002	00C	00D
Slot 1	0 None															
	1 I/O expansion															
Slot 2	0 None															
	1 Posl/O ³⁾															
Slot 3	0 None															
	1 Posl/O ³⁾															
	2 Posl/O-AIO ⁴⁾															
	C PMCprotego S1-2															
	D PMCprotego S2-2															

Standard bus systems: CANopen

We reserve the right to amend technical details

Features	Unit	Size (other sizes in preparation)									
		01	03	06	12	12P	24	24P	48	72	
Nominal data											
Supply voltage (power)	VAC	3 x 208 ... 3 x 480 V ±10 %									
Frequency range	Hz	50 ... 60									
Max. motor voltage	VAC	Mains voltage less 4 V					Mains voltage less 6 V				
Continuous output current (at 400 VAC)	A _{eff}	1.5	3	6	12		24		48	72	
Peak output current (max. 2 s)	A _{eff}	4.5	9	18	24	30	48	72	96	140	
Peak output current (max. 5 s)	A _{eff}	3	6	12	24	24	48		96	140	
Power consumption in S1 mode	kVA	1.1	2.2	4.5	9		18		35	50	
Output stage clock frequency at I _{rms}	kHz	8/16 (50% I _{rms})									
Supply voltage (electronics/with brake)	VDC	24 0 ... +15% (approx. 1 A/max. 3 A)							(approx. 2 A/ max. 5 A)		
Power dissipation at I _{rms}	W	40	70	100	160		330		635	1005	
Ballast circuit											
Internal brake resistor:											
Continuous output	W	50		75	100		200		-		
Max. peak output for max. 1 s	kW	15					23		-		
External brake resistor:	Ω	33					23		15	10	
Max. continuous output	kW	0.3	1		1.5		4		6	6	
Max. peak output for max. 5 s	kW	4 ... 21					6 ... 30		16 ... 70	16 ... 70	
Environmental conditions											
Ventilation		Forced ventilation through built-in fans									
Ambient temperature	°C	0 ... +40 at rated power, +40 ... +55 with power derating 2.5%/K									
Rel. humidity during operation	%	85, non-condensing									
Storage temperature	°C	-25 ... +55									
Installation height	m above sea level	Up to 1000 at rated power, 1000 ... 2500 with current reduction of around 1.5%/100 m									
Mechanics											
Weight	kg	4.4					5.5		13		
Dimensions (excl. connector)	Height	345					348		385		
	Width	70					100		190		
	Depth	243									



Further technical details in the installation manual

	010	01C	01D	020	02C	02D
Firmware option						
SafetyNET p ²⁾						
EtherCAT						
Options						
Standard						
I _{peak} = 3x ¹⁾						

¹⁾ With increased peak output current as an option

²⁾ In preparation

³⁾ Expansion card without analogue inputs and outputs

⁴⁾ Expansion card with analogue inputs and outputs

► Technical details – PM Ctendo DD5

Servo amplifier PM Ctendo DD5



PM Ctendo DD5

Technical details

- ▶ Position controller with max. 180 motion tasks
- ▶ Universal voltage range
- ▶ Intermediate circuits can be connected in parallel
- ▶ Supply voltage for control element 24 VDC
- ▶ 1 master encoder input
- ▶ 1 rotary encoder output
- ▶ CANopen
- ▶ Safe Torque Off (STO) up to SIL 2 of EN/IEC 62061, PL d of EN ISO 13849-1
- ▶ Integrated mains filter
- ▶ Internal brake resistor
- ▶ 4 digital inputs and 2 digital outputs
- ▶ 2 analogue inputs
- ▶ Protection type: IP20
- ▶ Mounting position: vertical
- ▶ CE certification and UL approval

Options

- ▶ D1 I/O expansion card with 14 inputs and 8 outputs
- ▶ Fieldbuses:
 - EtherCAT
 - PROFIBUS-DP-S

Type code

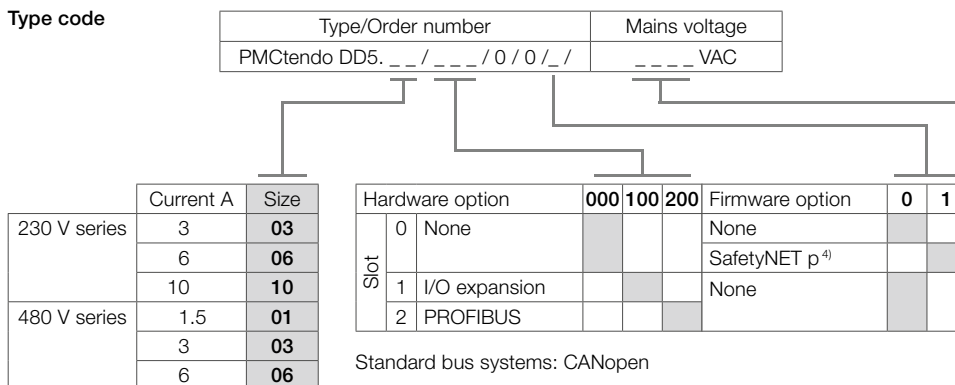

We reserve the right to amend technical details

Features	Unit	Size					
		03	06	10	01	03	06
Nominal data							
Mains voltage (power)	VAC	1 x 110 ... 1 x 230 V $\pm 10\%$, 3 x 110 ... 3 x 230 V $\pm 10\%$			3 x 208 ... 3 x 480 V $\pm 10\%$		
Frequency range	Hz	50 ... 60					
Max. motor voltage	VAC	Mains voltage less 5 V					
Continuous output current (at 3 x 230 V)	A _{eff}	3	6	10	-		
Peak output current (max. 5 s at 3 x 230 V)	A _{eff}	9	15	20	-		
Continuous output current (at 3 x 400 V)	A _{eff}	-			1.5	4	6
Peak output current (max. 5 s at 3 x 400 V)	A _{eff}	-			4.5	7.5	12
Power consumption in S1 mode	kVA	1.1	2.4	4	1.2	2.5	5
Output stage clock frequency at I _{rms}	kHz	8/16 (50% I _{rms})					
Supply voltage (electronics/with brake)	VDC	24 0 ... +15% (approx. 1 A/max. 2.5 A)					
Power dissipation at I _{rms}	W	35	60	90	40	60	90
Ballast circuit							
Internal brake resistor:							
Continuous output	W	20	50		20	50	
Max. peak output for max. 1 s	kW	3 ¹⁾			7 ²⁾		
External brake resistor:	Ω	66			91		
Max. continuous output	kW	0.3	1		0.3	1	
Max. peak output for max. 5 s	kW	3 ¹⁾			7 ²⁾		
Environmental conditions							
Ventilation ³⁾		None	With		None	With	
Ambient temperature	$^{\circ}\text{C}$	0 ... +40 at rated power, +40 ... +55 with power derating 2.5%/K					
Rel. humidity during operation	%	85, non-condensing					
Storage temperature	$^{\circ}\text{C}$	-25 ... +55					
Installation height	m above sea level	Up to 1 000 at rated power, 1 000 ... 2 500 with current reduction of around 1.5%/100 m					
Mechanics							
Weight	kg	2.6			2.7		
Dimensions (excl. connector)	Height	279					
	Width	70					
	Depth	171					

Further technical details in the installation manual

230 V series	110 ... 230 VAC
480 V series	208 ... 480 VAC

¹⁾ at 230 V

²⁾ at 400 V

³⁾ Forced ventilation through built-in fans

⁴⁾ In preparation

▶ Safe motion – Safety card PMCprotego S

The combination of the safety card PMCprotego S and the servo amplifier PMCprotego D produces the safe drive solution – safe motion. It is open for all standard PLC and motion control systems. Benefit from the high flexibility of our solution.

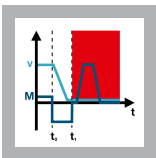
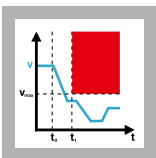
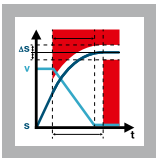

Protection of man and machine

Safe motion describes the implementation of safety functions for one or more drive axes. This is necessary to prevent uncontrollable movements. At the same time it guarantees the safety of personnel during operation, setup, format change or maintenance.

Open for individual requirements

The PMCprotego DS provides safe inputs and outputs to activate the safety functions. It also provides a variety of encoder interfaces plus a connection to all common bus systems.

Economical operation

Safe motion opens up new possibilities for co-operation between man and machine. For example, it's possible to set up machinery at "Safely Reduced Speed". This reduces the setup time and increases the availability of the process.

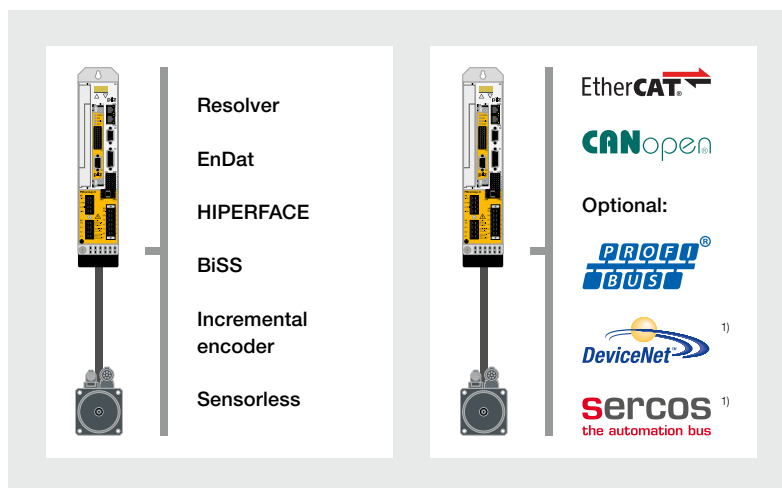

Complete one-stop automation solution

With the safety card PMCprotego S, the automation solution from Pilz is complete. You benefit from a complete one-stop solution. Compatible products and tools reduce the work involved in training and documentation. Optimum integration of the safety card PMCprotego S brings significant cost savings.

Openness thanks to a variety of encoder interfaces and bus systems.

¹⁾ On request

Safety with a standard encoder

Safety on the servo amplifier PMCprotego DS is based on the evaluation of internal system variables. The servo motor's existing standard feedback system is all that's needed for implementation. A second encoder is not required in order to achieve SIL 3, PL e, which reduces the overall costs.

Safe networking

Safe, sophisticated multi-axis applications are the result when the PMCprotego DS is connected to a control system with the real-time Ethernet SafetyNET p as the safe drive bus.

Simple diagnostics

Thanks to the PVIS diagnostic concept, system messages from the safe servo amplifiers PMCprotego DS are displayed in plain text on the diagnostic device PMI via the motion controller PMCprimo. Remedy messages are displayed for each event. PVIS significantly reduces downtimes in the case of a fault. Thanks to pre-defined messages, even project configuration is child's play.

Reduced reaction times

The servo amplifiers PMCprotego DS have integrated safety functions, opening up new possibilities for safe drive solutions. Motion is monitored precisely where it arises. Reaction times are reduced considerably as a result. This is very significant for safety, particularly with highly dynamic drives. Costs are reduced at the same time, as there are fewer external safety components.

Your benefits at a glance

- ▶ Highly dynamic, short reaction times
- ▶ Costs are reduced because the highest safety category PL e is achieved with one encoder (standard feedback system)
- ▶ Simple, fast commissioning
- ▶ Easy-to-use software tool
- ▶ Devices are easy to exchange thanks to the SD memory card (standard and safety configuration)
- ▶ Integrated diagnostics PVIS
- ▶ Less wiring
- ▶ Greater functionality and convenience, as internal system variables can be used
- ▶ Integrated mains filter enables costs to be reduced as the wiring work is no longer required (EMC standards are met)

Centralised view of decentralised safety –**One tool covers every axis**

The parameters for several safety cards are set centrally via a software tool. The cards that are used are displayed in a tree structure. Thanks to the clear graphical interface, parameters can be set simply and quickly. The current status of the safety card can be displayed online. This means that the operating status, error stack and other data can be monitored continuously.

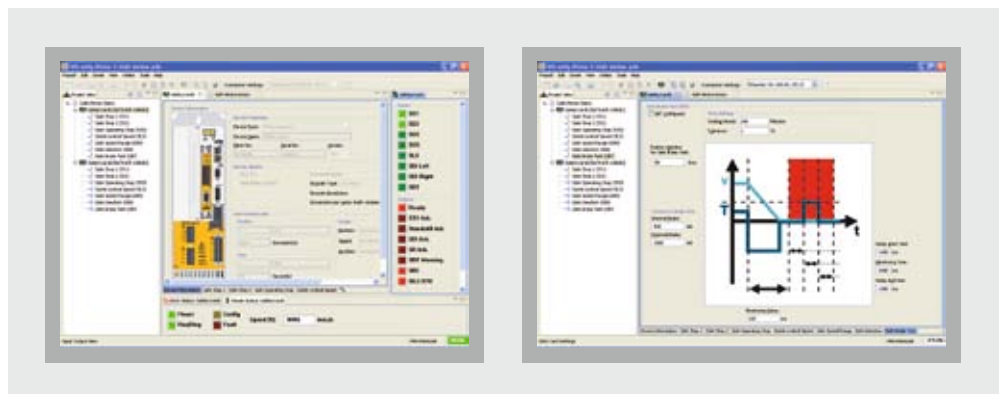

Clear user interface for simple parameter setting.

Keep up-to-date on the servo amplifier PMCprotego DS:

 **Webcode** 5263

Online information at www.pilz.com

► Technical details – PMCprotego S

Safety cards PMCprotego S

Common features

- ▶ Electrical data
 - External supply voltage U_B : 24 VDC
 - Power consumption (with no load): approx. 3 W
- ▶ Inputs
 - Galvanic isolation: Yes
 - Signal level at "0": -3 ... 5 V
 - Signal level at "1": 15 ... 30 V
- ▶ Single-pole/dual-pole outputs
 - Galvanic isolation: Yes
 - Electronic short circuit protection: Yes
 - Signal level at "0": 0 VDC
 - Signal level at "1": 24 VDC
- ▶ Environmental data
 - Protection type: IP20
 - Ambient temperature: 0 ... 40 °C
 - Storage temperature: -25 ... +55 °C
- ▶ Mechanical data
 - Dimensions in mm (H x W x D): 142 x 103 x 18.5
 - Installation: in PMCprotego D, Slot 3
 - Weight: 150 g



PMCprotego S

Features
Reaction times
Inputs/outputs (single-pole)
Output to control an external brake (dual-pole)
Brake
Encoder input
Standards
Safety functions
Order number

We reserve the right to amend technical details





	PMCprotego S1-2	PMCprotego S2-2
Error reaction time in ms	2	3
Response time of the safety functions in ms	4	5
Number of inputs	9	8
Number of single-pole outputs 0.5 A	7	5
Number of dual-pole outputs 2 A	1	-
Galvanic isolation	Yes	-
Control external brake < 2 A	via PMCprotego S1	-
Control external brake > 2 A	via external brake module	-
Number of external encoders	1 ¹⁾	-
Encoder type	SSI/incremental encoder	-
	SIL CL 3 of EN/IEC 62061 PL e of EN ISO 13849-1	SIL CL 2 of EN/IEC 62061 PL d of EN ISO 13849-1
Safe Torque Off (STO)	◆	◆
Safe Stop 1 (SS1)	◆	◆
Safe Stop 2 (SS2)	◆	◆
Safe Operating Stop (SOS)	◆	◆
Safely Limited Speed (SLS)	◆	◆
Safe Speed Range (SSR)	◆	◆
Safe Direction (SDI)	◆	◆
Safely Limited Increment (SLI)	◆	◆
Safely Limited Position (SLP)	◆	
Safe Brake Control (SBC)	◆	
Safe Brake Test (SBT)	◆	
	680004	680006

¹⁾ The Pilz solution is already safe with the servo motor's feedback system. If the risk assessment of the mechanical drive train requires a second encoder, a second, external encoder can be connected.

► Risk assessment

Risk assessments are the key to machinery safety. They pave the way for risk reduction that is both effective and economical. Many activities carried out by operators and maintenance staff represent a high risk. Pilz supports you in issues of risk assessment and machine safety based on applicable standards and directives.

1. Risk estimation

Determination of the required performance level (PL)

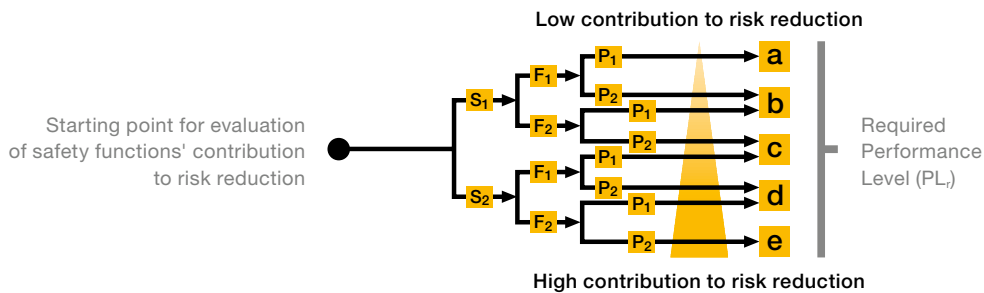

► S – Severity of injury

- S1 = Slight (normally reversible injury)
- S2 = Serious (normally irreversible injury or death)

► F – Frequency and/or exposure to hazard

- F1 = Seldom to less often and/or exposure time is short
- F2 = Frequent to continuous and/or exposure time is long

► P – Possibility of avoiding hazard or limiting harm

- P1 = Possible under specific conditions
- P2 = Scarcely possible

Product standards

EN 61496

Safety on electro-sensitive protective equipment

EN 61800-5-2

Safety functions for drives

Design specifications

EN ISO 13855

- Safety of machinery
- Layout of safety devices

EN ISO 12100

- Safety of machinery
- Principles for design and risk analysis
- General principles for design – Risk assessment and risk reduction

Application standards

EN 60204-1

Safety of electrical equipment

EN 62061

Functional safety for machinery (electrical incl. EMC)

EN ISO 13849

Safety-related parts of control systems (electrical and non-electrical)

EN 61326-3

EMC and functional safety

EN 61508

Functional safety, generic standards

EN 61511

Safety systems for the process industry

Drive-integrated safety

According to the Machinery Directive, the risks caused by the drive need to be considered when drive functions are designed, as well as the operating functions. The basis for this is IEC 61800-5-2. All the safety functions available on the PMCprotego DS meet the safety requirements stipulated by this standard. All the functions can be divided into safe stop, motion and brake functions.

Servo amplifiers PMCprotego D are also designed for SIL 3 of EN/IEC 62061 and PL e of EN ISO 13849-1.

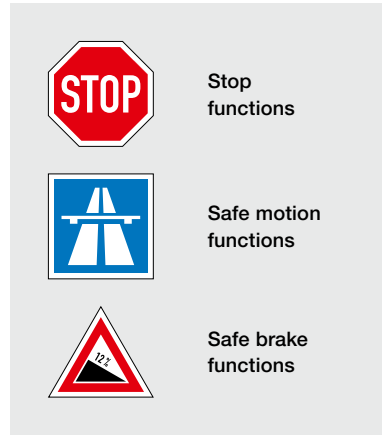

2. Selection of the measures required to minimise risk

In accordance with the Machinery Directive, every machine manufacturer is obliged to carry out a risk assessment. DIN EN ISO 12100 provides general guidelines for performing the risk assessment and identifying the hazards. Safe stop functions are used to prevent an unexpected start-up or to stop the plant safely in hazardous situations.

All the safety functions and standards' classifications are on the "Safe drive technology" poster:

Webcode 5263

Online information at www.pilz.com

Safe stop functions – Overview

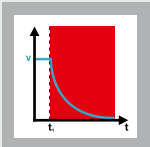

Safe Torque Off (STO)

With the "Safe Torque Off" function, the power to the motor is safely removed directly within the servo amplifier. The drive cannot generate any hazardous movements. If the STO is activated when the drive is moving, the motor will run down in an uncontrolled manner.

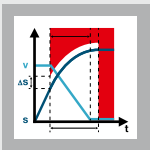

Safe Stop 1 (SS1)

With a "Safe Stop 1" function, the drive is brought to a controlled stop and then the power to the motor is safely removed. Once at a standstill, the drive cannot generate any hazardous movements. On gravity-loaded axes, the drive must also be secured by a mechanically-based braking concept.

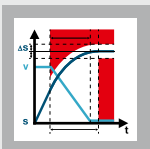

Safe Stop 2 (SS2)

With a "Safe Stop 2" function, the drive is brought to a controlled stop and then a "Safe Operating Stop" is initiated. In a "Safe Operating Stop", the drive's control functions are maintained in full.

M = Torque, s = Distance, t = Time, v = Velocity

Various requirements from the Machinery Directive concern operating modes that necessitate human intervention on the machine. This intervention can also take place while safeguards are partially disconnected. Various solutions are allowed, depending on the design or the duration of exposure. While in many applications switching off a motor is usually a safe solution, in the case of vertical axes switching off could present a danger.

► Risk reduction measures

Risk

Suspended loads/vertical axes

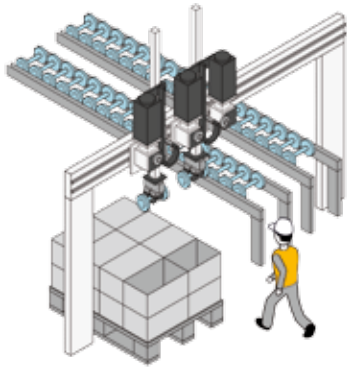

Measures

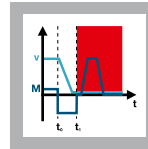

Safe Brake Test (SBT)

The “Safe Brake Test” function checks the function of the brake. This test can be used to identify any faults in the brake’s control and mechanics. The brake test may be carried out in each production cycle or only every 24 hours, depending on the specific application and the requirement from the risk analysis.

Setup

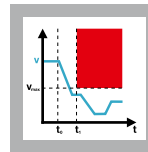
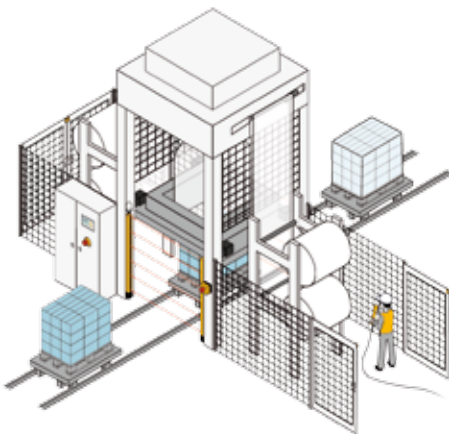

Safely Limited Speed (SLS)

The “Safely Limited Speed” function monitors the drive to check that a defined maximum speed is not exceeded. If the speed limit value is exceeded, the drive is shut down safely.

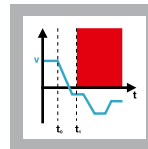

Safe Direction (SDI)

The “Safe Direction” function guarantees that a drive can only move in one (defined) direction. If the specified direction is violated, the drive is shut down safely.

Intervention in the process

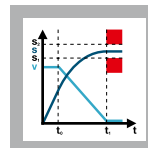
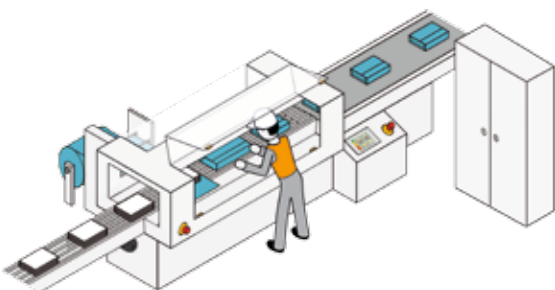

Safe Operating Stop (SOS)

The “Safe Operating Stop” function monitors the stop position reached by the axis and prevents any deviation from the position window. The drive’s control functions are maintained in full. If the position strays outside of the monitored window, the drive is shut down safely. On gravity-loaded axes, the drive must also be secured by a mechanically-based braking concept.

Additional possible measures for risk reduction are the safe stop functions: Safe Torque Off (STO), Safe Stop 1 (SS1), Safe Stop 2 (SS2). More information on page 33.

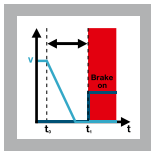

Safe Brake Control (SBC)

The “Safe Brake Control” function enables brakes to be controlled safely, thereby preventing suspended loads from falling.

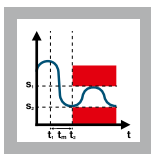

Safely Limited Position (SLP)

The “Safely Limited Position” function monitors the end positions of previously defined ranges. If a limit value is violated, the drive is shut down safely.

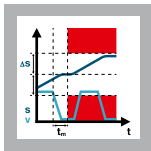

Safely Limited Increment (SLI)

The “Safely Limited Increment” function monitors the movements of the drive for compliance with a defined increment. The reference position is defined when monitoring is activated. If a limit value is violated, the drive is shut down safely.

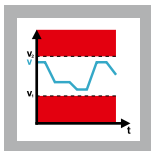

Safe Speed Range (SSR)

The “Safe Speed Range” function adds minimum speed monitoring to the SLS function. In other words, the maximum speed must not exceed a certain value, and the minimum speed must not drop below a certain value. If either of these limits is violated, the drive is shut down.

Benefits

Maintenance work

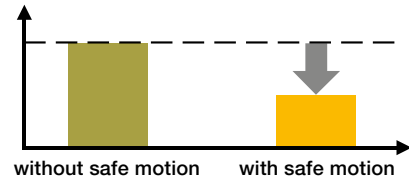

By automatically testing the braking action, safe brake functions lead to:

- ▶ Reduced maintenance
- ▶ Increased productivity and availability
- ▶ Higher level of safety

Time

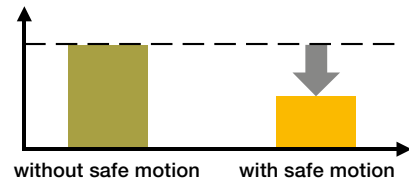

Working safely with the guards open leads to

- ▶ Reduced setup times as there is a better insight into the setup area
- ▶ Greater work safety by guaranteeing that the direction of movement corresponds to the selected jog function
- ▶ Greater work safety due to safely limited setup speeds

Productivity

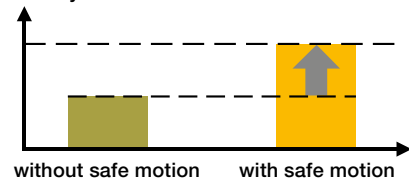

Safe Operating Stop (SOS and SSR) leads to higher productivity because

- ▶ Axis synchronisation is maintained
- ▶ Plants are restarted quickly and more simply
- ▶ Safety level is higher as the plant is protected against unexpected restart

M = Torque, s = Distance, t = Time, v = Velocity

► Retrieve and calculate safety performance data

3. Evaluation of the safety functions

There are different device types because each manufacturer uses different parameters, due to technological differences. The safety performance data is defined by the application.

- Device type 1: Safety-related devices with evaluation of the integrated diagnostics. The classification is specified by the device manufacturer.
- Device type 2: Devices with a failure mode that is time-dependent. Additional application data is required in order for the user to evaluate a safety function.
- Device type 3: Devices with a failure mode that depends on the switching frequency. Additional application data is required in order for the user to evaluate a safety function.
- Device type 4: Special form of device type 1, but without random, dangerous failures ($PFH_D = 0$).

Further information on assessment and verification of safety functions

Webcode 0820

Online information at www.pilz.com

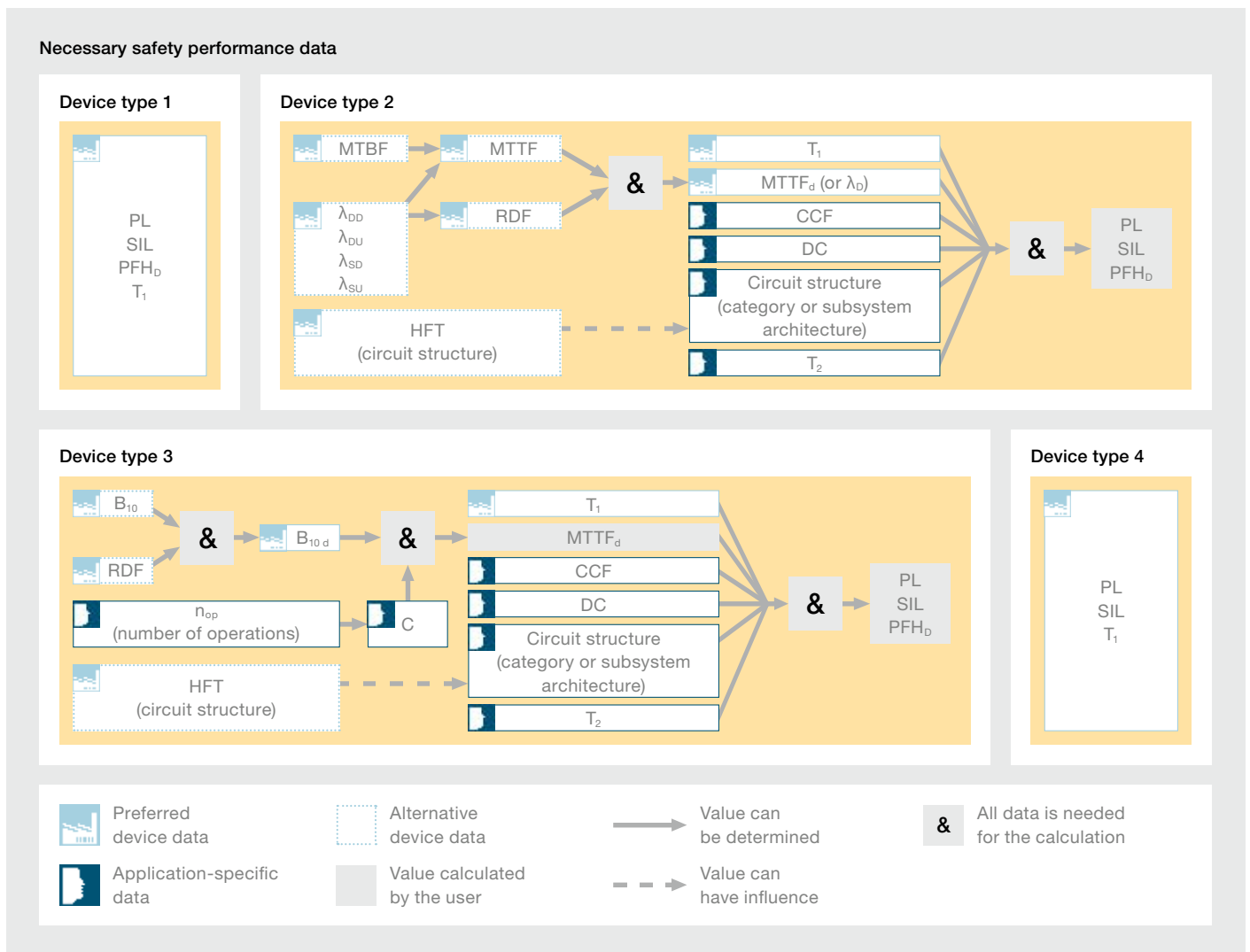

The calculation is performed in accordance with EN ISO 13849-1 (e.g. with the calculation tool PAScal).

4. Verification of safety functions

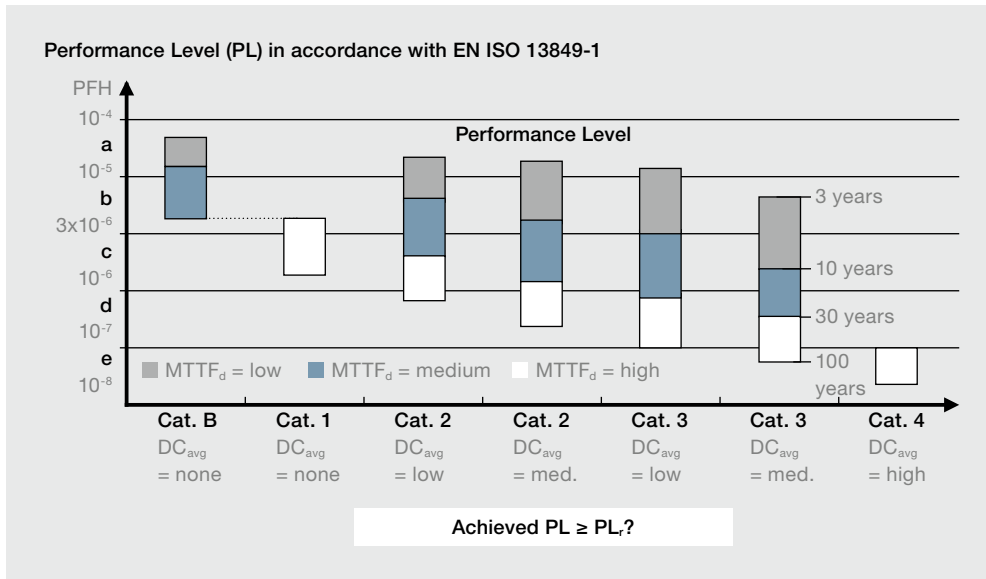

Relationship between the categories DC, MTTFd_d and PL.

To produce a safety concept, the life phases, operating modes, user tasks, actions and the associated hazards and risks must all be considered. In addition to the emergency stop and automatic mode, the machine should also be considered more closely in setup mode and during maintenance work. The following consideration is given as an example for lifting equipment.

Emergency operation: Active in all operating modes

If the emergency stop button is pressed, a “Safe Stop 1” (SS1) must be initiated and then the brakes activated.

Setup mode

If the operating mode selector switch is turned to Setup, this mode's safety functions will be active, so movements even while the safeguard is open are possible under reduced risk with a guard locking device and active enabling function. Speed is safely monitored during this process; if a limit value is violated, a “Safe Stop 1” (SS1) will result and the holding brake will be activated when the axis comes to a standstill.

Automatic mode

As long as the operating mode selector switch is turned to Automatic, all movements are only possible if the guard is closed and interlocked using a a guard locking device. If the locked guard (safety gate) is opened, a “Safe Stop 2” (SS2) is triggered. In addition, the minimum and maximum speed of the vertical axis is monitored thanks to “Safe Speed Range” (SSR). If the limit is exceeded, the “Safe Stop 1” (SS1) is triggered and the brakes are activated at standstill.

A prolonged stay under the gravity-loaded axis is essential in the case of maintenance, repair and cleaning. This means that the axis must be supported from underneath or locked mechanically.

You can order posters on functional safety EN 12100, EN ISO 13849-1, EN/IEC 62061 from:

Webcode 3301

Online information at www.pilz.com

► PMCtools – Professional tools

Motion control made simple – professional tasks require professional tools. Use our comprehensive software to configure, program and monitor your machine.

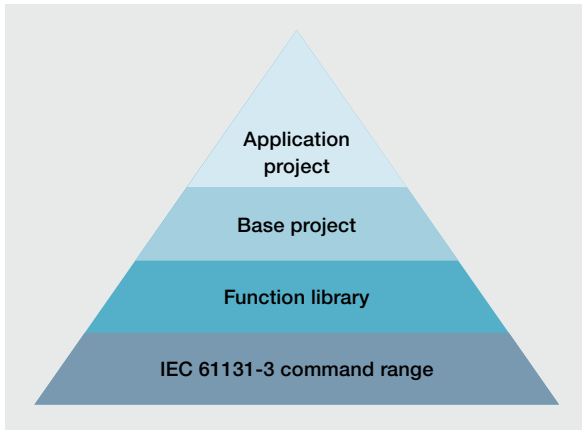

Universal programming in accordance with IEC 61131-3 guides you through an application, from planning to production. All the key components for commissioning an automation system are integrated.

From the rapid generation of motion curves through to simple drive parameterisation. Nothing presents a problem thanks to the integrated commissioning tools.

Programming environment under IEC 61131-3

The basis for the entire programming is a soft PLC under IEC 61131-3. Individual programming requirements are considered thanks to the five editors. The system is compatible on both Pilz control platforms PMCprimo 16+ and PMCprimo Drive. External devices are easy to integrate via various bus systems thanks to the resource manager.

Function libraries

A large number of standard libraries provide all common PLC and motion control functions. The function libraries for curve and drive parameterisation are a particular feature. They form the interface to the graphical auxiliary programs and act as a memory cell for the calculated data.

Software with integrated motion control functions (base project)

The base project's ready-made program structures simplify the implementation of the application considerably, as the motion part is pre-programmed and fully functional. All that's left is to adapt the specific parameters and program the calls for the various operating states.

Parameterisation instead of programming (application project)

Ready-made application projects can be employed if common functions such as cross cutting, flying saw, synchronisation or similar are used on your machine, whether individually or in combination. You can dispense with time-consuming programming; all you need to do is adapt the application-specific parameters on the operator terminal.

PMC software



Software PMC

Type	Application	Order number
Motion Control Tools	Configuration software for motion control devices	1 802 959 ¹⁾
CoDeSys Target	Software to enable CoDeSys functionality, incl. motion control tools	¹⁾
PASconfig SDrive	Parameter software for safety cards PMCprotego S (Safe Motion)	¹⁾

¹⁾ Free to download from www.pilz.com/support/downloads/

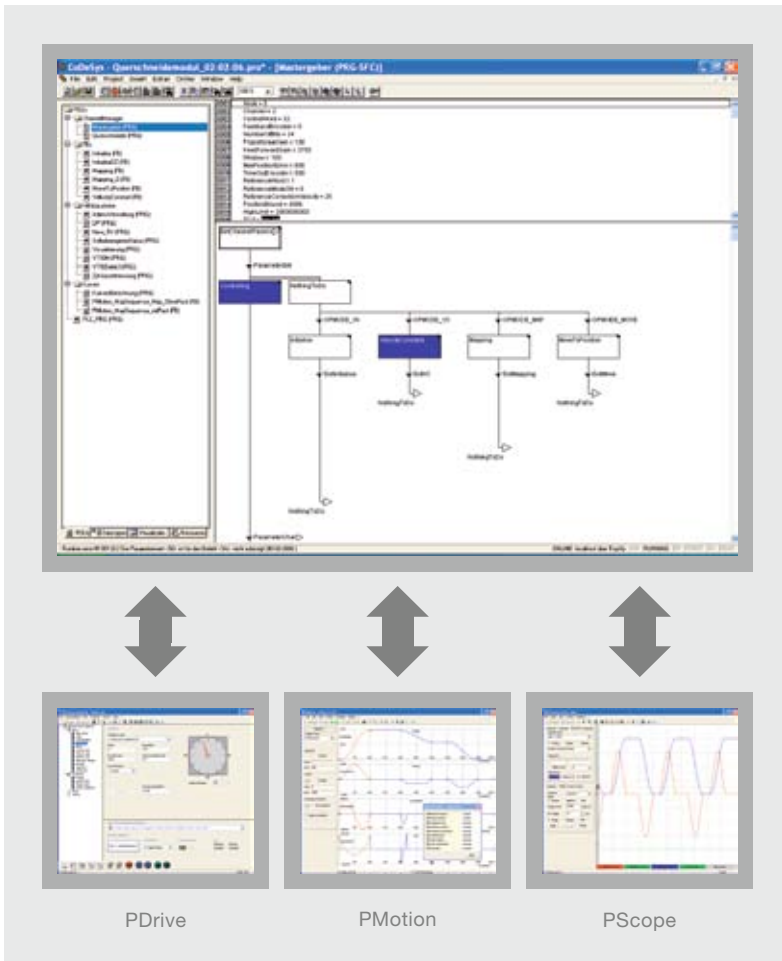

Your benefits at a glance

- ▶ Parameterisation instead of programming thanks to base projects/application projects
- ▶ Safe handling of all automation data and programs, as everything is combined in one project
- ▶ Save time thanks to simple operation and ready-made function blocks
- ▶ Your drives can be commissioned quickly and easily thanks to graphic tools and a storage oscilloscope
- ▶ From planning to production: Everything in one project file thanks to universal programming in accordance with IEC 61131-3

Setting parameters for the servo amplifier with PDrive

A complete parameter database is available for all common servo amplifier/motor combinations.

Curve generation with PMotion

Master-slave relationships can be created quickly and easily using the sophisticated plotting program PMotion. It is possible to display the angle assignment, as well as speed, acceleration and shock for the motor and mechanical design. The Master-Slave relationships created graphically with PMotion can be influenced by offsets in the PLC program at runtime. It is also possible to switch between the various Master-Slave tables during operation.

Graphical diagnostics with PScope

PScope is a powerful diagnostic tool. All relevant analogue and digital processes in the control system and drives are displayed graphically on the PC.

Parameter software for safe motion

Thanks to the clear, graphical interface of the PASConfig SDrive tool, parameters for the safety cards PMCprotego S can be set simply and quickly.

Keep up-to-date on Pilz Motion Control Tools software:

 Webcode 8636

Online information at www.pilz.com

▶ Servo motors PMCtendo SZ



PMCtendo SZ servo motors represent a modern range of servo motor. Here you'll find the right motor for each specific application. Whether the focus is on dimensions, dynamics, controllability or feedback systems.



PMCtendo SZ (convection-cooled)



PMCtendo SZ (forced air-cooled)



PMCtendo SZ (water-cooled)

Good controllability

The excellent controllability of the PMCtendo SZ motors is achieved using the high resolution absolute encoder as a feedback system. Through this you can read out the absolute position of the motors during operation. Even when the machine has been switched off or there is a power failure, the absolute position will still be available.

More than just motors

All motors are available with a range of gear units. Special versions, forced air fans, water coolers etc. are also available.

Support with your motor design

Three different motor sizes are available in the standard product range. On request we can also supply customised solutions. And of course, Pilz application engineers will provide support with the motor design and definition of the power transmission.

Compact design, high performance

Thanks to their high power density, the servo motors PMCtendo SZ have an extremely short overall length and are also lightweight. As a result they are particularly suitable where conditions are cramped and for on-board axes. Precise motor synchronisation, due to low cogging torques, provides constantly high process quality.

Selection guide – Servo motors PMCtendo S

Type
PMCtendo SZ3x
PMCtendo SZ4x
PMCtendo SZ5x
PMCtendo SZ7x
PMCtendo SZ8x

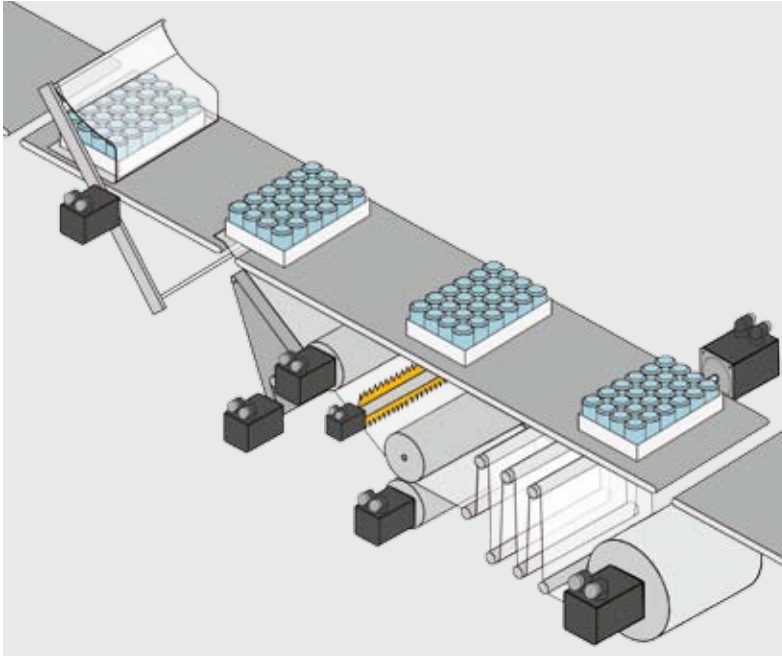

Your benefits at a glance

- ▶ High dynamics and torque stability
- ▶ Excellent ratio between torque/moment of inertia
- ▶ Extremely quiet operation in all speed ranges
- ▶ Smooth operation at low speed
- ▶ High reliability even in extreme working conditions
- ▶ High resolution absolute value encoder systems for highest performance and absolute positioning
- ▶ Competent support with your motor design

The appropriate, decentralised drive for every detail.

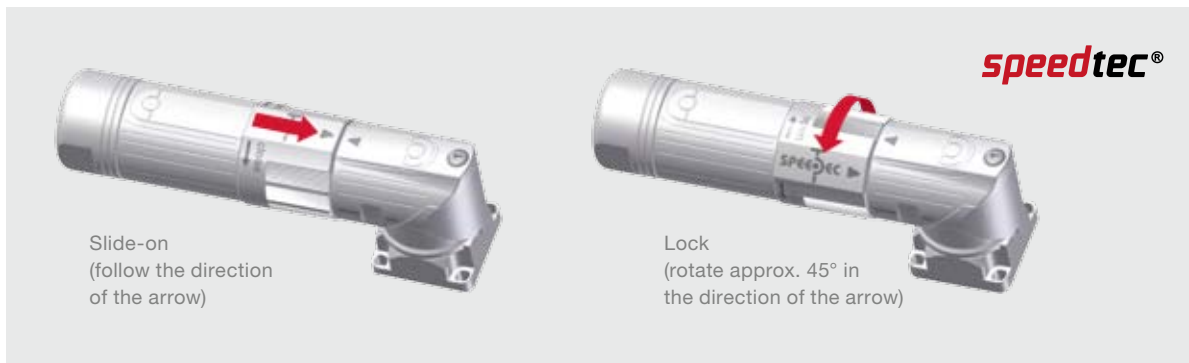

Servo motors PMCtendo can be commissioned quickly using quick-lock speedtec connectors.

SZ

Standstill torque Convection M_0 in Nm	Forced air fan M_0 in Nm	Water cooling M_0 in Nm	Rated speed n_N in U/min	Flange in mm
0.95 ... 2.25	-	-	3000, 6000	60
2.80 ... 8.60	3.5 ... 11.2	3.35 ... 11.3	3000, 6000	95
4.40 ... 16.00	5.7 ... 23.4	5.55 ... 21.5	3000, 4500	110
7.90 ... 30.20	10.2 ... 41.8	10.40 ... 39.4	3000, 4500	130
34.50 ... 66.10	47.4 ... 94.0	46.90 ... 90.1	2000, 3000, 4500	180

Keep up-to-date on servo motors PMCtendo SZ:

 Webcode 5284

Online information at www.pilz.com

► Technical details – PMCtendo SZ

Servo motors PMCtendo SZ



PMCtendo SZ



General technical details

- ▶ Extremely short overall length
- ▶ Smooth shaft
- ▶ High dynamics due to low inertia
- ▶ Rotary speedtec connector
- ▶ Therm. winding protection PTC
- ▶ Protection type: IP56
- ▶ Surface: black, matt RAL 9005
- ▶ EnDat absolute encoder: single-turn or multi-turn
- ▶ UL and CSA approval for the motor insulation system

The performance data in the tables below refers to the following boundary conditions:

- ▶ Rated voltage: 400 V
- ▶ Operating mode: S1 at rated operation
- ▶ Maximum heating: 100 K
- ▶ Cooling: Convection in accordance with IC410
- ▶ Ambient temperature: +5 ... +40 °C
- ▶ Heat class: F
- ▶ Installation height: 1 000 m above sea level

Options

- ▶ Holding brake: 24 VDC
- ▶ Increased inertia
- ▶ Resolver
- ▶ Protection type: IP66
- ▶ Hiperface feedback system
- ▶ External IP44 fan to IC416
- ▶ Water cooling, A-side motor flange

Motor size

Common dimensions in mm

Motor size	Common dimensions in mm				
	øb1 ¹⁾	øe1 ²⁾	ød ³⁾	l	a
41	95j6	115	14k6	30	98
42	95j6	115	19k6	40	98
44	95j6	115	19k6	40	98
51	110j6	130	19k6	40	115
52	110j6	130	19k6	40	115
53	110j6	130	24k6	50	115
55	110j6	130	24k6	50	115
71	130j6	165	24k6	50	145
72	130j6	165	24k6	50	145
73	130j6	165	24k6	50	145
75	130j6	165	32k6	58	145

Convection-cooled:

PMCtendo SZ:
convection-cooled, without brake

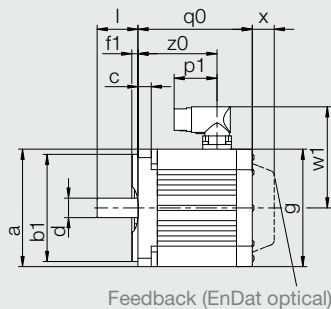

PMCtendo SZ:
convection-cooled, with brake

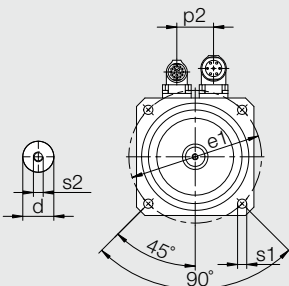
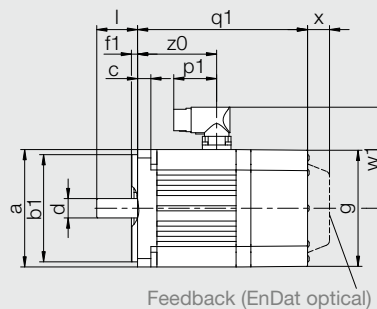

Forced air-cooled:

PMCtendo SZ:
forced air-cooled, without brake

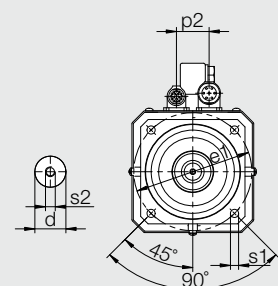
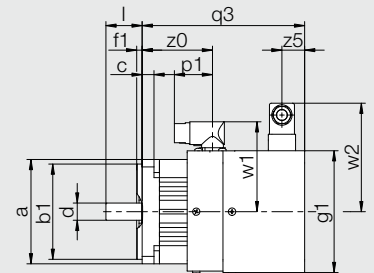

We reserve the right to amend technical details

c	f1	p1	p2	øS1	øS2	w1	z0	Convection-cooled				Forced air-cooled				Water-cooled		
								g	q0	q1	x	g1	q3	q4	w2	z5	w3	z7
9.5	3.5	40	32	9	M5	91	76.5	98	118.5	167.0	22	118	175	224	111	25	49	12.5
9.5	3.5	40	32	9	M5	91	101.5	98	143.5	192.0	22	118	200	249	111	25	49	12.5
9.5	3.5	40	32	9	M5	91	151.5	98	193.5	242.0	22	118	250	299	111	25	49	12.5
10.0	3.5	40	36	9	M6	100	74.5	115	109.0	163.5	22	135	179	234	120	25	70	10.5
10.0	3.5	40	36	9	M6	100	99.5	115	134.0	188.5	22	135	204	259	120	25	70	10.5
10.0	3.5	40	36	9	M6	100	124.5	115	159.0	213.5	22	135	229	284	120	25	70	10.5
10.0	3.5	40	36	9	M6	100	174.5	115	209.0	263.5	22	135	279	334	120	25	70	10.5
10.0	3.5	40	42	11	M8	115	83.0	145	121.0	180.0	22	165	213	272	134	40	72	10.5
10.0	3.5	40	42	11	M8	115	108.0	145	146.0	205.0	22	165	238	297	134	40	72	10.5
10.0	3.5	40	42	11	M8	115	133.0	145	171.0	230.0	22	165	263	322	134	40	72	10.5
10.0	3.5	71	42	11	M8	134	184.0	145	226.0	285.0	22	165	318	377	134	40	72	10.5

1) Centering 2) Bolt hole 3) Shaft

PMctendo SZ:
forced air-cooled, with brake

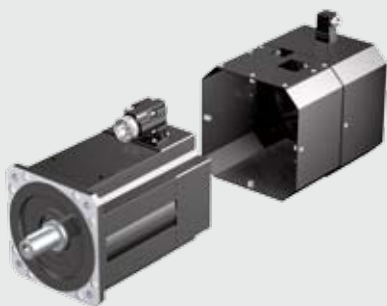
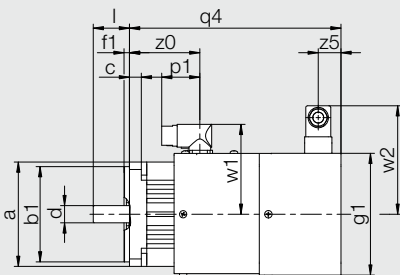

Water-cooled:

PMctendo SZ4x and
PMctendo SZ5x: water-cooled

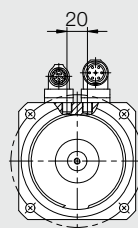
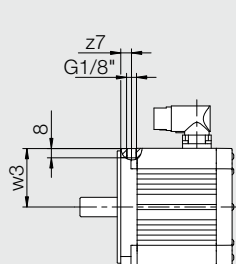

PMctendo SZ7x:
water-cooled

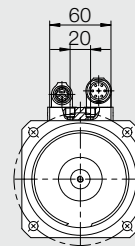
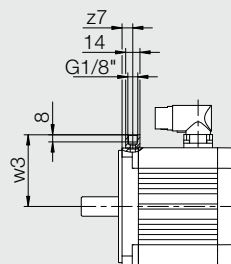

Further dimensions are the same as for the "convection-cooled" version.

► Technical details – PMCtendo SZ

Performance data PMCtendo SZ convection-cooled

Motor size	Rated speed	Constant standstill torque	Rated torque	Peak torque	Moment of inertia without brake	Torque constant	Constant standstill current (eff.)	Peak current (eff.)	Rated output	EMF voltage constant	Weight without brake
	n_N min ⁻¹	M_0 Nm	M_N Nm	M_{max} Nm	J 10 ⁻⁴ kgm ²	K_M Nm/A	I_0 A	I_{max} A	P_N kW	K_E V/1000 min ⁻¹	m kg
41	6000	2.8	2.3	8.5	0.93	0.530	5.36	33.0	1.40	47	4.0
	3000	3.0	2.8	8.5	0.93	1.056	2.88	16.5	0.88	96	4.0
42	6000	4.9	3.5	16.0	1.63	0.665	7.43	43.5	2.20	60	5.1
	3000	5.2	4.7	16.0	1.63	1.092	4.80	26.5	1.50	94	5.1
44	6000	8.4	5.8	29.0	2.98	0.863	9.78	51.0	3.60	78	7.2
	3000	8.6	6.9	29.0	2.98	1.309	6.60	35.0	2.20	116	7.2
51	6000	4.4	3.4	16.0	2.90	0.769	5.80	31.0	2.10	68	5.0
	3000	4.7	4.3	16.0	2.90	1.190	4.00	22.0	1.40	97	5.0
52	6000	7.8	5.2	31.0	5.20	0.802	9.80	59.0	3.30	72	6.5
	3000	8.0	7.4	31.0	5.20	1.399	5.76	33.0	2.30	121	6.5
53	6000	10.6	6.2	43.0	7.58	0.921	11.60	63.5	3.90	84	8.0
	3000	11.1	9.7	43.0	7.58	1.455	7.67	41.0	3.10	119	8.0
55	4500	15.3	9.5	67.0	12.20	1.148	13.40	73.0	4.50	103	10.9
	3000	16.0	13.5	67.0	12.20	1.606	10.00	52.0	4.20	141	10.9
71	6000	7.9	5.2	20.0	8.50	0.868	9.38	31.0	3.30	76	8.3
	3000	8.3	7.4	20.0	8.50	1.068	8.00	25.0	2.30	95	8.3
72	6000	14.3	7.2	41.0	13.70	0.879	16.50	60.5	4.50	82	10.8
	3000	14.4	12.0	41.0	13.70	1.525	9.60	36.0	3.80	133	10.8
73	4500	20.0	12.1	65.0	21.60	1.137	17.80	78.0	5.70	99	12.8
	3000	20.8	16.5	65.0	21.60	1.503	14.00	62.0	5.20	122	12.8
75	4500	30.0	16.4	104.0	34.00	1.200	25.20	114.0	7.70	106	18.3
	3000	30.2	21.3	104.0	34.00	1.561	19.50	87.0	6.70	140	18.3

Performance data PMCtendo SZ forced air-cooled

41	6000	3.5	2.9	8.5	0.93	0.518	6.83	33.0	1.8	47	5.4
	3000	3.7	3.4	8.5	0.93	1.039	3.60	16.5	1.1	96	5.4
42	6000	6.4	5.1	16.0	1.63	0.690	9.34	43.5	3.2	60	6.5
	3000	6.3	5.9	16.0	1.63	1.093	5.80	26.5	1.9	94	6.5
44	6000	10.5	8.0	29.0	2.98	0.878	12.00	51.0	5.0	78	8.6
	3000	11.2	10.2	29.0	2.98	1.292	8.70	35.0	3.2	116	8.6
51	6000	5.7	4.5	16.0	2.90	0.768	7.50	31.0	2.8	68	7.0
	3000	5.8	5.4	16.0	2.90	1.172	5.00	22.0	1.7	97	7.0
52	6000	10.5	8.2	31.0	5.20	0.788	13.40	59.0	5.2	72	8.5
	3000	11.2	10.3	31.0	5.20	1.380	8.16	33.0	3.2	121	8.5

All technical details are values for the dynamic version of motors. Technical details for increased inertia can be found on page 46. All the stated details apply to motors with a rated voltage of 400 V. We reserve the right to amend technical details.

Performance data PMctendo SZ forced air-cooled

Motor size	Rated speed	Constant standstill torque	Rated torque	Peak torque	Moment of inertia without brake	Torque constant	Constant standstill current (eff.)	Peak current (eff.)	Rated output	EMF voltage constant	Weight without brake
	n_N min ⁻¹	M_0 Nm	M_N Nm	M_{max} Nm	J 10 ⁻⁴ kgm ²	K_M Nm/A	I_0 A	I_{max} A	P_N kW	K_E V/1000 min ⁻¹	m kg
53	6000	14.8	10.4	43.0	7.58	1.068	15.9	63.5	6.5	84	10.0
	3000	15.9	14.4	43.0	7.58	1.353	11.8	41.0	4.5	119	10.0
55	4500	22.0	16.4	67.0	12.20	1.138	19.4	73.0	7.7	103	12.9
	3000	23.4	20.2	67.0	12.20	1.596	14.7	52.0	6.4	141	12.9
71	6000	10.2	7.5	20.0	8.50	0.842	12.4	31.0	4.7	76	13.3
	3000	10.5	9.7	20.0	8.50	1.074	10.0	25.0	3.1	95	13.3
72	6000	19.3	12.5	41.0	13.70	0.886	22.1	60.5	7.9	82	15.8
	3000	19.3	16.6	41.0	13.70	1.515	12.9	36.0	5.2	133	15.8
73	4500	27.2	19.8	65.0	21.60	1.134	24.2	78.0	9.3	99	17.8
	3000	28.0	24.0	65.0	21.60	1.412	20.0	62.0	7.5	122	17.8
75	4500	39.4	27.7	104.0	34.00	1.209	32.8	114.0	13.0	106	23.3
	3000	41.8	33.8	104.0	34.00	1.586	26.5	87.0	11.0	140	23.3

Performance data PMctendo SZ water-cooled

41	6000	3.35	2.55	8.5	0.93	0.488	6.95	33.0	1.6	47	4.0
	3000	3.55	3.30	8.5	0.93	0.921	3.90	16.5	1.0	96	4.0
42	6000	6.45	5.00	16.0	1.63	0.669	9.70	43.5	3.1	60	5.1
	3000	6.35	5.85	16.0	1.63	1.065	6.00	26.5	1.8	94	5.1
44	6000	10.60	7.70	29.0	2.98	0.865	12.30	51.0	4.8	78	7.2
	3000	11.30	10.40	29.0	2.98	1.274	8.90	35.0	3.3	116	7.2
51	6000	5.55	4.30	16.0	2.90	0.774	7.25	31.0	2.7	68	5.0
	3000	5.65	5.40	16.0	2.90	1.177	4.85	22.0	1.7	97	5.0
52	6000	10.30	8.10	31.0	5.20	0.803	12.90	59.0	5.1	72	6.5
	3000	11.00	10.20	31.0	5.20	1.409	7.85	33.0	3.2	121	6.5
53	6000	14.20	9.95	43.0	7.58	0.938	15.20	63.5	6.3	84	8.0
	3000	15.20	13.50	43.0	7.58	1.350	11.30	41.0	4.2	119	8.0
55	4500	20.20	14.20	67.0	12.20	1.178	17.20	73.0	6.7	103	10.9
	3000	21.50	17.90	67.0	12.20	1.655	13.10	52.0	5.6	141	10.9
71	6000	10.40	7.00	20.0	8.50	0.834	12.70	31.0	4.4	76	8.3
	3000	10.40	10.20	20.0	8.50	1.064	10.00	25.0	3.2	95	8.3
72	6000	19.30	12.00	41.0	13.70	0.856	22.50	60.5	7.5	82	10.8
	3000	19.30	17.10	41.0	13.70	1.470	13.10	36.0	5.4	133	10.8
73	4500	26.70	19.10	65.0	21.60	1.139	23.70	78.0	9.0	99	12.8
	3000	27.50	22.50	65.0	21.60	1.415	19.60	62.0	7.1	122	12.8
75	4500	37.20	24.10	104.0	34.00	1.185	31.60	114.0	11.0	106	18.3
	3000	39.40	30.30	104.0	34.00	1.561	25.40	87.0	9.5	140	18.3

► Technical details – PMCtendo SZ

Technical details: increased inertia and brake

Motor size	Additional values for motors with increased inertia		Brake			
			Static torque	Brake current	Mass moment of inertia	Weight of brakes
	ΔJ 10^{-4} kgm^2	Δm kg	M_{BS} Nm	I_B A	J_B 10^{-4} kgm^2	m_B kg
41	0.2	0.08	4.0	0.75	0.192	0.76
42	0.4	0.15	8.0	0.75	0.566	0.97
44	0.8	0.31	8.0	0.75	0.566	0.97
51	-	-	8.0	0.75	0.571	1.19
52	1.1	0.22	8.0	0.75	0.571	1.19
53	2.0	0.43	15.0	1.00	1.721	1.62
55	4.1	0.87	15.0	1.00	1.721	1.62
71	-	-	15.0	1.00	1.743	1.94
72	4.4	0.41	15.0	1.00	1.743	1.94
73	6.3	0.81	32.0	1.10	5.68	2.81
75	13.6	1.60	32.0	1.10	5.68	2.81

Type code

Type/Order number	Size	Brake	Feedback	Design	Connection	Cooling	Voltage	Speed	Option
PMCtendo SZ	--	-	-	-	-	-	-	--	--

Dimensions/overall length	
PMCtendo SZ3x	3x
PMCtendo SZ4x	4x
PMCtendo SZ5x	5x
PMCtendo SZ7x	7x
PMCtendo SZ8x	8x

Without brake	0
With brake	1
Without brake/increased mass inertia	2
With brake/increased mass inertia	3

EnDat 2.2 induct. single-turn ECI 1118 ¹⁾	1
EnDat 2.2 optical multi-turn EQN 1135 ²⁾	2

B5, smooth shaft	2
------------------	----------

¹⁾ EnDat 2.2 inductive single-turn: 18 bit resolution per revolution

²⁾ EnDat 2.2 optical multi-turn: 23 bit resolution per revolution, each with 12 Bit

Technical details: fan

Motor size	Connection voltage	Frequency	Current	Rated power	Fresh air flow rate	Noise	Weight without brake
	U_F V	F Hz	I_F A	P_F W	Q_F m ³ /h	G_F dBA	m_F kg
4x	230 +6 %/-10 %	50/60 Hz	0.07	10	59	41	1.4
5x	230 +6 %/-10 %	50/60 Hz	0.10	14	160	45	1.9
7x	230 +6 %/-10 %	50/60 Hz	0.10	14	160	45	2.9



00 Standard

- 20 2 000 min⁻¹
- 30 3 000 min⁻¹
- 45 4 500 min⁻¹
- 60 6 000 min⁻¹

H 400 V

- K Convection-cooled
- F Forced air-cooled
- W Water-cooled

7 Angled swivel connector for motor and feedback

We reserve the right to amend technical details

► Safe motion monitoring on vertical axes

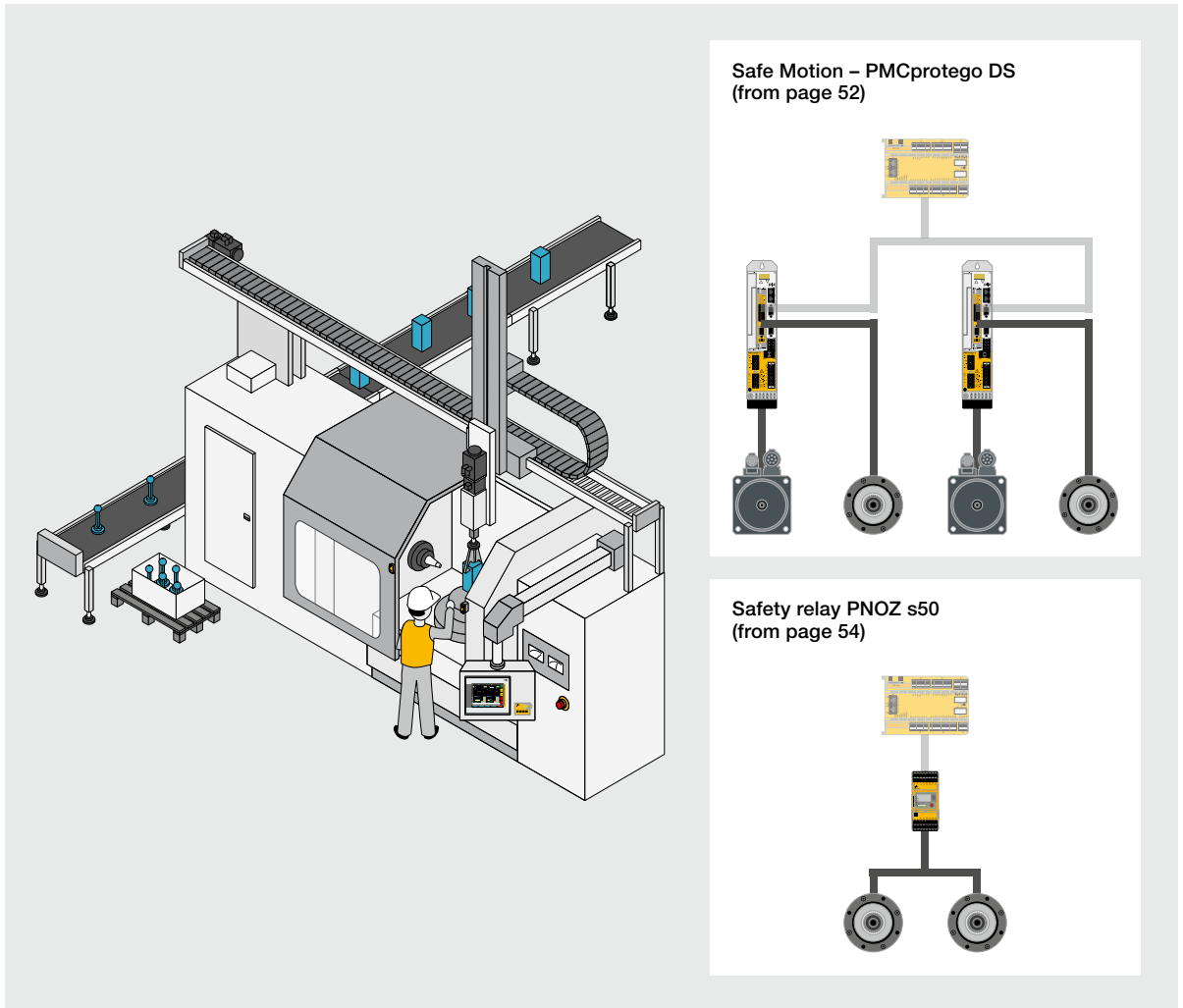

Safe setup on a lathe with linear robot.

There is an enormous amount of danger in automated production, particularly from gravitational forces in the case of vertical movements, if a power failure occurs or a braking device fails. A risk assessment must consider the risks of unintended descent and define measures to minimise the risk.

Pilz offers various solutions in the field of safe motion monitoring on vertical axes:

- Safe Motion – drive-integrated safety functions for safeguarding holding brakes with cyclical testing
- Safety relay PNOZs50 – Safe brake control and monitoring of holding brakes or safety brakes

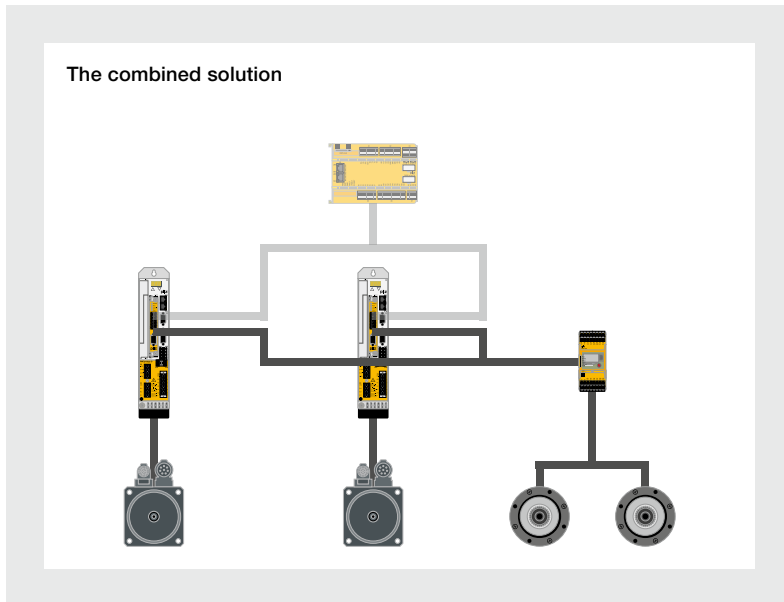

The combination of the safety relay PNOZ s50 and the safe motion solution PMCprotego DS gives users a safe, overall solution, which combines functions such as safe brake test, safe control of high-performance brakes and cyclical function check of the brake's open position. In combination with PNOZ s50, PMCprotego DS monitors the drive-integrated safety function and simultaneously controls an external brake. As such

the solution represents an intelligent, highly efficient combination for all applications with the very highest safety requirements on vertical axes. Thanks to the high output current of 4.5 A, which is available at both outputs when the supply voltage is 24 VDC, it is now possible to control even high-performance holding brakes and safety brakes for heavy loads. Even peak currents of up to 6.5 A can be covered if necessary.



► Complete solutions on vertical axes

Application example

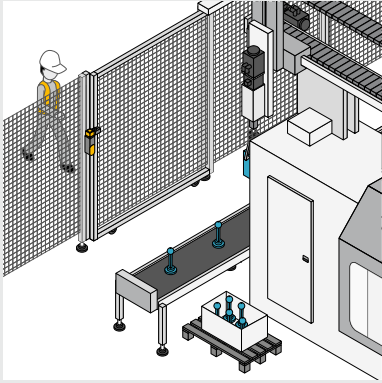

Operator is present outside the access-protected area.

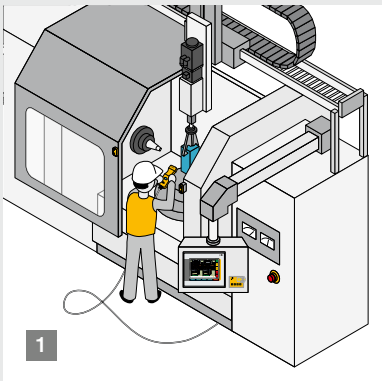

Hazardous situation 1:
Upper limbs of operator are present below the vertical axis and exposure time is low.

Operating modes

Automatic mode

Set-up mode

Guard with guard locking device:



Mechanical safety switch
PSENmech



Safety bolt
PSENbolt

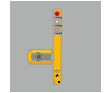

Safety gate system
PSENsgate

When the safety gates is closed¹⁾:

Before the guard locking device is deactivated, a cyclical test of the braking equipment is performed by the machine control in accordance with Cat. 2, EN ISO 13849-1:



Servo amplifier PMCprotego DS – Safe Motion

When the safety gates is open²⁾:

If access to the protected area is possible, the safeguarding provisions of hazardous situations 1 and 2 apply:



Servo amplifier PMCprotego DS – Safe Motion

+ Measures for set-up mode in accordance with the standard, e.g. EN ISO 10218-1, DIN EN 12417:



Manually operated control device
PITjog



Enabling switch
PITenable

Safe solution



Configurable control systems
PNOZmulti



Control system
PSSuniversal PLC

Application example

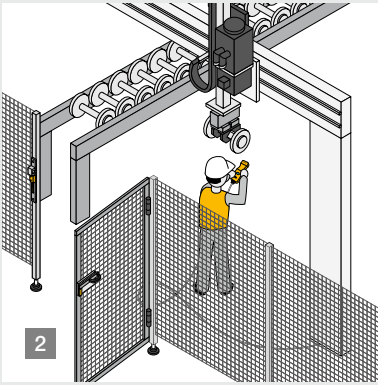

Hazardous situation 2:
The operator puts his whole body under the vertical axis.

Legend

- ¹⁾ The servo amplifier PMCprotego D prevents unexpected start-up. The safety card PMCprotego S is used to perform the cyclical brake test:
- ▶ If a guard is present, a brake test before every entry (immediately before the guard locking device is enabled) is sufficient
 - ▶ The brake test is carried out at 1.3 times the load torque (if one brake is used)
 - ▶ The safety card also permits the "Safe Operating Stop" (SOS), which safely monitors the stop position reached by the axis and prevents the axis leaving the position window
 - ▶ In many cases the brake test can remove the need for costly mechanical or hydraulic counterbalances

²⁾ The vertical axis must be safely prevented from starting up unexpectedly.

Operating modes

Automatic mode

Redundant device for protection in accordance with Cat. 3, EN ISO 13849-1 ²⁾.

It may be necessary to use a second brake. As there is usually only one holding brake integrated within the motor, an additional, external brake is required.



Safety relay PNOZ s50 with feedback loop for monitoring the air on external brakes

Set-up mode

Before the guard locking device is deactivated, a cyclical test of the braking equipment is performed by the machine control in accordance with Cat. 2, EN ISO 13849-1¹⁾:



Servo amplifier
PMCprotego DS – Safe Motion

+ Measures for set-up mode in accordance with the standard, e.g. EN ISO 10218-1, DIN EN 12417:



Manually operated control device PITjog



Enabling switch
PITenable

When the exposure time is high:

Redundant device for protection in accordance with Cat. 3, EN ISO 13849-1 ²⁾.

It may be necessary to use a second brake. As there is usually only one holding brake integrated within the motor, an additional, external brake is required.



Safety relay
PNOZ s50



Control and signal devices PIT



Operating mode selector switch PITmode



Operator terminals PMI

► Cyclical testing of holding brakes with Safe Motion

The holding brake that exists for process reasons does not normally offer sufficient protection against falling suspended loads. That is because mechanical wear or oil contamination can mean that the rated braking torque of the brake is not reached. This can result in the axis collapsing.



Safe motion – Servo amplifier PMCprotego D with integrated safety card PMCprotego S.

Depending on the risk assessment, a holding brake with cyclical testing may suffice as protection. This presupposes that the probability of descent is rated lower, as either a protective structure prevents access below the vertical axis or the exposure time for particular activities is low.

Safe working on vertical axes

PMCprotego DS uses the “Safe Brake Test” (SBT) to check the function of the brake. The brake test may be carried out in each production cycle or only every 8 hours, depending on the specific application and the requirement from the risk analysis. During the test the brake is loaded with additional torque. If the position changes during testing, this is identified as an inadmissible state and results in a message that prevents further operation. The plant is shut down safely to allow the brake to be repaired.

As well as the “Safe Brake Test” (SBT), safe motion also enables other safety functions to be realised. Motion functions such as “Safely Limited Speed” (SLS) and stop functions such as “Safe Torque Off” (STO) enable reduced set-up times and increase availability for the process.

All safety functions with PMCprotego DS meet the requirements of the Machinery Directive based on IEC 61800-5-2 and are designed up to PL e of EN ISO 13849-1 and SIL CL 3 of EN/IEC 62061.



– PMCprotego DS

Flexible connection

The safe motion solution can easily be integrated into any existing system environment. That's because PMCprotego DS is suitable for connecting or integrating motion control systems PMCprimo directly in the servo amplifier, but is also open for connecting to standard PLC and motion control systems through interfaces such as analogue/digital, CANopen, S7 – PROFIBUS-DP or EtherCAT, for example.

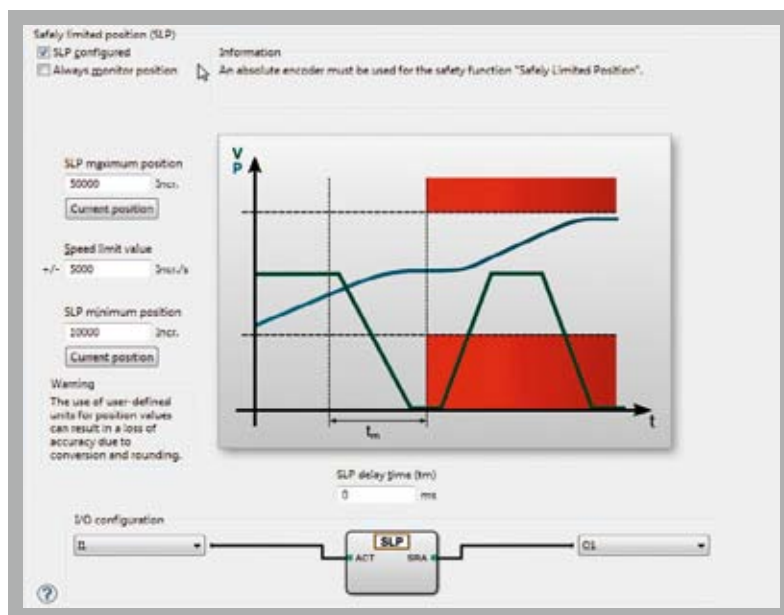

Easy parameterisation with PASconfig SDrive

Configuration of the safety card is simple and user-friendly with PASconfig SDrive. Thanks to its informative graphics, this software tool is a part of the Pilz safety concept because user information helps to prevent invalid entries. The inputs and outputs of the safety card S1-2 can be flexibly assigned to one or more safety functions in the configurator. Functions such as “Safely Limited Speed” (SLS) and “Safe Direction” (SDI) can be started via a common input and can be connected to a digital output on the safety card separately or together. This reduces the work involved in programming and wiring.

Your benefits at a glance

- ▶ Very short reaction times of up to 2 ms at maximum performance due to the integrated stop functions
- ▶ Simple integration within an existing system environment thanks to open interfaces
- ▶ High flexibility thanks to safe digital inputs and outputs that are compatible with all programmable safety systems on the market
- ▶ Safe, dual-pole, digital output for activating a brake
- ▶ Mechanical fault exclusion is not required because breaks are monitored through an additional external encoder
- ▶ Reduction in total costs because the highest safety category – PL e – is achieved with one encoder
- ▶ Maximum safety thanks to wear monitoring with SBT

Keep up-to-date on:
PMCprotego DS:



Webcode 5263

Online information at www.pilz.com

► Safety relay PNOZ s50 for safe brake control

The stand-alone safety relay PNOZ s50 offers an economical solution for controlling two brakes up to category PL e of EN ISO 13849-1. The contactless technology allows very short reaction times to be achieved, enhancing personal protection. You can take advantage of the full flexibility and the individual shutdown options for your application of this manufacturer-independent solution.



PNOZ s50

Safe, contactless braking – so it's non-wearing

PNOZ s50 helps to make your plant energy efficient: Application cycle times are shortened because temporary excitation is followed by selectable voltage reduction (pulse width modulation PWM). The safety relay allows rapid switching in emergency situations and slow, low-wearing switching in normal operation, thereby helping to reduce maintenance costs.

As an addition to the PNOZsigma product range, PNOZ s50 has a rotary knob for menu navigation and a display for showing setup parameters and diagnostic messages.

Both motor brakes and safety brakes can be safely controlled and monitored with the safety relay PNOZ s50. Safety is significantly improved due to “wear monitoring”, particularly on motor-integrated holding brakes (but not holding brakes).



Find out more in the animation on the safety relay PNOZ s50

Safety relay PNOZ s50



PNOZ s50

Technical features

- ▶ Stand-alone device
- ▶ 2 brakes up to PL e of EN ISO 13849-1 or SIL CL 3 of EN/IEC 62061
- ▶ 1 brake up to PL d of EN ISO 13849-1 or SIL CL 3 of EN/IEC 62061
- ▶ 2 x 2-pole safe electronic digital outputs for 24 VDC, each 4.5 A
- ▶ Temporary overexcitation with subsequent voltage reduction
- ▶ Ambient temperature: 0 ... 45 °C
- ▶ Number of inputs:
 - Failsafe: 4
 - Standard: 4
- ▶ Number of failsafe semiconductor outputs:
 - 1-pole: 3
 - 2-pole: 2

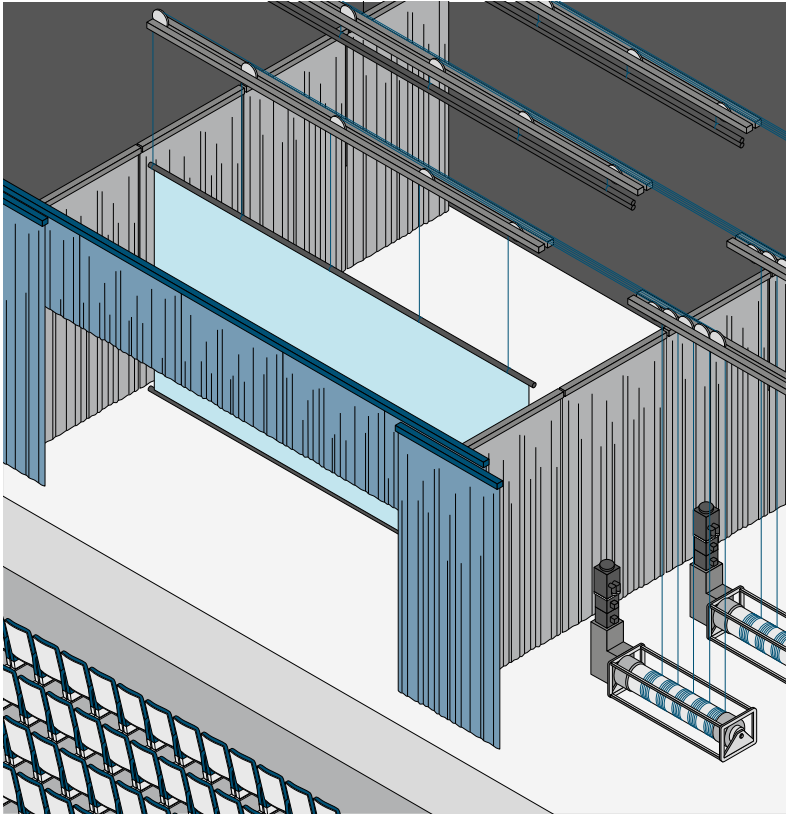

In many applications it is necessary to safeguard an additional brake alongside the holding brake. In the field of stage technology, for example, winches are operated with a dual brake.

Your benefits at a glance

- ▶ Maximum safety up to PL e when controlling 2 brakes (holding brakes or safety brakes)
- ▶ Contactless technology up to 4.5 A per brake allows short reaction times, a long-lasting solution and high availability
- ▶ Reduced cycle times through temporary overexcitation with subsequent voltage reduction
- ▶ High safety and low wear on the brake thanks to fast and slow shutdown of the power circuits
- ▶ Rapid diagnostics by means of display
- ▶ Manufacturer-independent brake control thanks to safe, digital inputs

- ▶ Supply voltage:
 - 1-pole 24 VDC
 - 2-pole 24 VDC, 48 VDC
- ▶ Voltage tolerance:
 - 1-pole: -15 % ... +20 %
 - 2-pole: -10 % ... +10 %
- ▶ Output current of semiconductor outputs (1-pole): 0.1 A
- ▶ Test pulse outputs – semiconductor outputs (1-pole): 2

- ▶ Reduced voltage of semiconductor outputs (2-pole): 6 V, 8 V, 12 V, 16 V, 24 V
- ▶ Output current of semiconductor outputs (2-pole):
 - 24 VDC supply voltage:
 - Continuous duty (1 output/2 outputs): 1 x 6.5 A/2 x 4.5 A
 - Overexcitation (1 output/2 outputs): 1 x 6.5 A/ $\Sigma = 10$
 - 48 VDC supply voltage:
 - Continuous duty (1 output/2 outputs): 1 x 3.25 A/2 x 2.25 A
 - Overexcitation (1 output/2 outputs): 1 x 3.25 A/2 x 3.25 A

Order number

751 500
(with spring-loaded terminals)

Technical documentation on safety relays PNOZ s50:

 Webcode 5229

Online information at www.pilz.com

► Selection guide – Accessories for drive technology

Here you will find a selection of our wide range of accessories: from gear units to individually customised cable and connection types, through to appropriate feedback systems for the application.

Accessories: motor choke and gear unit

Type	Features
Motor choke	-
Gearboxes	-

Accessories: CAN adapters



PMCprotego
D.CAN-Adapter
01-24A

Type	Features
PMCprotego D.CAN-Adapter 01-24A	Networking aid in the amplifier, terminating resistor can be selected
PMCprotego D.CAN-Adapter 48-72A	
PMCprimo DriveP.CAN-CAN-Adapter 01-24	
PMCprimo DriveP.CAN-CAN-Adapter 48-72	
PMCprimo DriveP.CAN-PROFI-Adapter 01-24	
PMCprimo DriveP.CAN-PROFI-Adapter 48-72	
PM Ctendo DD4.CAN-Adapter Slot version	

Accessories: brake resistor for PM Ctendo DD5 and PMCprotego D



Resistance

Type	Features
Brake resistor 300W/66R/T/U	Used to remove excess energy from the system. Due to the compact design, the various sizes are suitable for wall mounting or for assembly on or in the control cabinet.
Brake resistor 300W/91R/T/U	
Brake resistor 600W/66R/T/U	
Brake resistor 600W/91R/T/U	
Brake resistor 600W/33R/T/U	
Brake resistor 1600W/33R/T/U	
Brake resistor 600W/23R/T/U	
Brake resistor 1600W/23R/T/U	
Brake resistor 1600W/15R/T/U	
Brake resistor 1600W/10R/T/U	

Accessories: mains filter



Mains filter

Type	Features
Mains filter for DD FFU 3X07K-KK	For advanced environmental protection against mains-bound interference.
Mains filter for DD FFU 3X16K-KK	
Mains filter for DD FFU 3X30K-KK	
Mains filter for DD FFU 3X42K-KK	
Mains filter for DD FFU 3X100K-KK	

Individually customised accessories are available for your application on request. Please contact us!

Suitable for	Electrical data
PMCprimo Drive3, PM Ctendo DD5, PMCprotego D	Mains voltage: up to 3 x 400 VAC Rated current: n stages up to 3 x 25 A
PM Ctendo SZ	Calculated from the design of the power transmission

Suitable for	Connection options	Order number
PMCprotego D up to 24 A rated current	D-Sub connector for 2x CANopen and 1x RS 232; terminating resistor can be selected	8 176 300
PMCprotego D 48 ... 72 A rated current		8 176 470
PMCprimo C in PMCprotego D up to 24 A rated current	D-Sub connector for 1x CANopen, 1x PROFIBUS-DP and 1x RS 232; terminating resistor can be selected	680 040 ¹⁾
PMCprimo C in PMCprotego D 48 ... 72 A rated current		680 042 ¹⁾
PMCprimo C in PMCprotego D up to 24 A rated current		680 041 ¹⁾
PMCprimo C in PMCprotego D 48 ... 72 A rated current		680 043 ¹⁾
PM Ctendo DD5	D-Sub connector for 2x CANopen and 1x RS 232; terminating resistor and monitoring voltage switch can be selected	8 163 583

¹⁾ incl. RJ45 cable to connect the fieldbus junction box to the PMCprimo DriveP

Suitable for	Rated power ²⁾ W	Resistance Ω	Order number
PM Ctendo DD5/PMCprimo Drive3, 110 ... 230 VAC	300	66	8 176 378
PM Ctendo DD5/PMCprimo Drive3, 208 ... 480 VAC	300	91	8 176 092
PM Ctendo DD5/PMCprimo Drive3, 110 ... 230 VAC	600	66	8 176 380
PM Ctendo DD5/PMCprimo Drive3, 208 ... 480 VAC	600	91	8 176 188
PMCprotego D.01 ... D.12	600	33	8 176 372
PMCprotego D.01 ... D.12	1 600	33	8 176 374
PMCprotego D.24	600	23	8 176 332
PMCprotego D.24	1 600	23	8 176 334
PMCprotego D.48	1 600	15	8 176 376
PMCprotego D.72	1 600	10	8 176 364

²⁾ at 40 °C ambient temperature and 100 % continuous duty

Rated current A	Leakage current 50 Hz		Power dissipation W	Order number
	typ. mA	max. mA		
7	<35	100	4	8 171 507
16	<35	100	8	8 171 509
30	<35	100	12	8 170 535
42	<35	100	15	8 166 771
100	<35	100	24	8 176 382

► Selection guide – Cable accessories

Cable accessories and connectors



PMCcable FD/D4B6/005/Q25/S1



PMCcable M2/B1B2/005/1Q5/S1



PMCcable M2/C2B2/005/1Q5/S1



PMCcable M2/C2B3/005/2Q5/S1



PMCcable M2/C1B3/005/4Q0/S1



PMCprotego motor connector kit

Type

PMCcable FD/D4B6/005/Q25/S1
PMCcable FD/D4B6/010/Q25/S1
PMCcable FD/D4B6/015/Q25/S1
PMCcable FD/D4B6/020/Q25/S1
PMCcable M2/B1B2/005/1Q5/S1
PMCcable M2/B1B2/010/1Q5/S1
PMCcable M2/B1B2/015/1Q5/S1
PMCcable M2/B1B2/020/1Q5/S1
PMCcable M2/C2B2/005/1Q5/S1
PMCcable M2/C2B2/010/1Q5/S1
PMCcable M2/C2B2/015/1Q5/S1
PMCcable M2/C2B2/020/1Q5/S1
PMCcable M2/C2B2/005/2Q5/S1
PMCcable M2/C2B2/010/2Q5/S1
PMCcable M2/C2B2/015/2Q5/S1
PMCcable M2/C2B2/020/2Q5/S1
PMCcable M2/C2B2/005/4Q0/S1
PMCcable M2/C2B2/010/4Q0/S1
PMCcable M2/C2B2/015/4Q0/S1
PMCcable M2/C2B2/020/4Q0/S1
PMCcable M2/C2B3/005/2Q5/S1
PMCcable M2/C2B3/010/2Q5/S1
PMCcable M2/C2B3/015/2Q5/S1
PMCcable M2/C2B3/020/2Q5/S1
PMCcable M2/C2B3/005/4Q0/S1
PMCcable M2/C2B3/010/4Q0/S1
PMCcable M2/C2B3/015/4Q0/S1
PMCcable M2/C2B3/020/4Q0/S1
PMCcable M2/C1B3/005/4Q0/S1
PMCcable M2/C1B3/010/4Q0/S1
PMCcable M2/C1B3/015/4Q0/S1
PMCcable M2/C1B3/020/4Q0/S1
PMCcable M2/C1B3/005/6Q0/S1
PMCcable M2/C1B3/010/6Q0/S1
PMCcable M2/C1B3/015/6Q0/S1
PMCcable M2/C1B3/020/6Q0/S1
PMCprotego motor connector kit

Features	Suitable for	Length ¹⁾	Order number
<ul style="list-style-type: none"> ▶ Feedback cable for EnDat 2.2 ▶ M23 speedtec encoder connector 	<ul style="list-style-type: none"> ▶ PMCtendo DD5 ▶ PMCprotego D ▶ PMCtendo SZ 	5 m	8 177 101
		10 m	8 177 102
		15 m	8 177 103
		20 m	8 177 104
<ul style="list-style-type: none"> ▶ Power cable ▶ 4 x 1.5 + 1 x (2 x 1.0) ▶ M23 speedtec motor connector 	<ul style="list-style-type: none"> ▶ PMCtendo DD5 ▶ PMCtendo SZ 	5 m	8 177 141
		10 m	8 177 142
		15 m	8 177 143
		20 m	8 177 144
<ul style="list-style-type: none"> ▶ Power cable ▶ 4 x 1.5 + 1 x (2 x 1.0) ▶ M23 speedtec motor connector 	<ul style="list-style-type: none"> ▶ PMCprotego D.01-24 ▶ PMCtendo 	5 m	8 177 151
		10 m	8 177 152
		15 m	8 177 153
		20 m	8 177 154
<ul style="list-style-type: none"> ▶ Power cable ▶ 4 x 2.5 + 1 x (2 x 1.0) ▶ M23 speedtec motor connector 	<ul style="list-style-type: none"> ▶ PMCprotego D.01-24 ▶ PMCtendo SZ 	5 m	8 177 161
		10 m	8 177 162
		15 m	8 177 163
		20 m	8 177 164
<ul style="list-style-type: none"> ▶ Power cable ▶ 4 x 4.0 + 1 x (2 x 1.5) ▶ M23 speedtec motor connector 	<ul style="list-style-type: none"> ▶ PMCprotego D.01-24 ▶ PMCtendo SZ 	5 m	8 177 171
		10 m	8 177 172
		15 m	8 177 173
		20 m	8 177 174
<ul style="list-style-type: none"> ▶ Power cable ▶ 4 x 2.5 + 1 x (2 x 1.0) ▶ M40 speedtec motor connector 	<ul style="list-style-type: none"> ▶ PMCprotego D.01-24 ▶ PMCtendo SZ 	5 m	8 177 181
		10 m	8 177 182
		15 m	8 177 183
		20 m	8 177 184
<ul style="list-style-type: none"> ▶ Power cable ▶ 4 x 4.0 + 1 x (2 x 1.5) ▶ M40 speedtec motor connector 	<ul style="list-style-type: none"> ▶ PMCprotego D.01-24 ▶ PMCtendo SZ 	5 m	8 177 191
		10 m	8 177 192
		15 m	8 177 193
		20 m	8 177 194
<ul style="list-style-type: none"> ▶ Power cable ▶ 4 x 4.0 + 1 x (2 x 1.5) ▶ M40 speedtec motor connector 	<ul style="list-style-type: none"> ▶ PMCprotego D.48-72 ▶ PMCtendo SZ 	5 m	8 177 201
		10 m	8 177 202
		15 m	8 177 203
		20 m	8 177 204
<ul style="list-style-type: none"> ▶ Power cable ▶ 4 x 6.0 + 1 x (2 x 1.5) ▶ M40 speedtec motor connector 	<ul style="list-style-type: none"> ▶ PMCprotego D.48-72 ▶ PMCtendo SZ 	5 m	8 177 211
		10 m	8 177 212
		15 m	8 177 213
		20 m	8 177 214
<ul style="list-style-type: none"> ▶ Consisting of X9 connector and shielded terminal ▶ On 48 A and 72 A versions, the screw terminals are connected directly to the servo amplifier 	<ul style="list-style-type: none"> ▶ PMCprotego D up to 24 A ▶ PMCprimo DriveP up to 24 A 	-	8 176 330

¹⁾ Additional lengths on request

► Green light for energy savers

Energy efficiency in drive technology should always take a holistic approach, including every component. If energy is saved, then the power dissipation in the control cabinet will also be lower, depending on the measures taken, so that cooling can at least be reduced, if not removed all together. Cooler control cabinets and a longer service life for the components are the direct result. Energy efficiency also increases process stability and ensures higher machine availability.



Potential savings with safe drive technology PMC

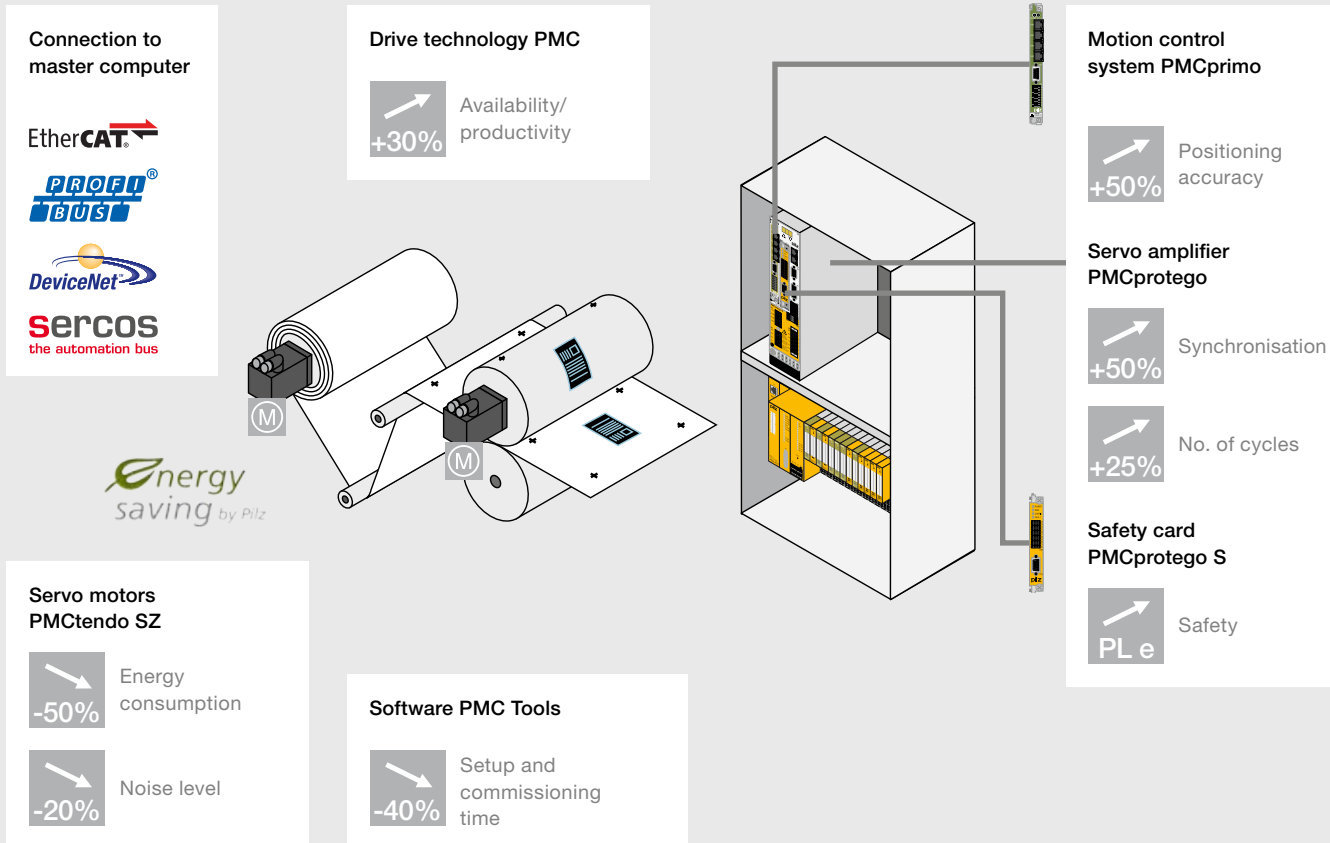

Potential savings with Pilz Motion Control PMC

The control system PMCprimo DriveP from Pilz combines motion control, PLC and safety functions in one device and requires little space in the control cabinet. PMCprimo DriveP is designed for applications with multiple axes and high requirements for performance and synchronised movements. Print mark detection for each axis means that the control system can drive more axes, in other words larger plant and machinery, simultaneously and with faster system reaction times.

Appropriate software tools help users get started. Clear project documentation also helps to save time.

If a safety-related application is required, PMCprimo DriveP can also be expanded with the safety card PMCprotego S. With this expansion it is possible to use standard motor feedback systems to achieve SIL 3/PL e for a wide range of safety functions, such as "Safely Reduced Speed". The result is an all-in-one motion control solution for drive, control and safety.

Use of the very latest energy-saving servo motors is particularly worthwhile because in many cases it is possible to save up to half of the absorbed energy. The noise level can also be reduced significantly.

Your benefits at a glance

- ▶ All-in-one solution combines motion control, safe motion and PLC in one device
- ▶ Energy-efficient servo technology: Maximum no. of cycles/machine output
- ▶ Flexible connection to master computer
- ▶ Parameters are easy to set using PMC Tools



► Green light for energy savers

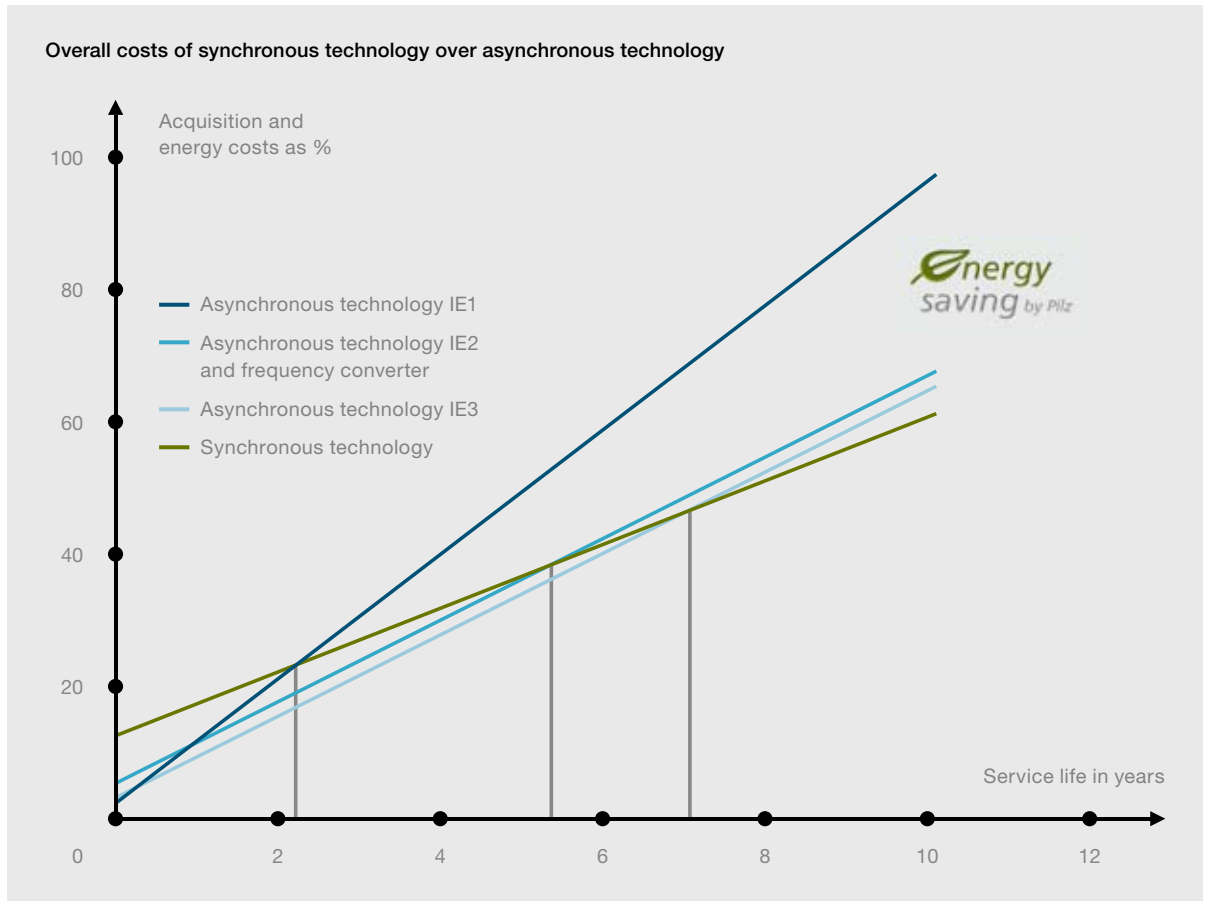

After > 2 years, synchronous technology is already more economical than asynchronous technology.

Complete solutions with synchronous motors are generally the better choice in terms of energy balance. If the machine builder considers that the previous price advantage of asynchronous technology is significantly reduced with the new standard IEC 60034-30, the conversion to synchronous motors makes sense for many applications. Pilz offers efficient solutions in this area, which help you to implement not only safety but also the required energy efficiency in drive technology.





Servo motors ensure efficient energy provision

Due to their extremely short overall length and low weight, servo motors PMCTendo SZ have a high power density. Thanks to their high efficiency factor, these motors are particularly energy-saving; in many applications they exceed the requirements of the international efficiency class IE4, as specified by the standard. Even heat dissipation is optimised, ensuring permanently high performance. High resolution absolute value encoder systems guarantee high performance and a fast system start without a reference run. PMCTendo SZ are characterised

by extremely quiet operation and high process quality thanks to low cogging torques. As a result, the servo motors are ideal for use in applications with on-board axes – with frequently changing speeds for example – and in cramped conditions. The new servo motors PMCTendo SZ are available with different cooling types – as water coolers, forced air fans or with natural convection. Water-cooled motors achieve around 35 per cent higher performance than the basic convection model. They can also be used with high ambient temperatures, without any loss in performance.

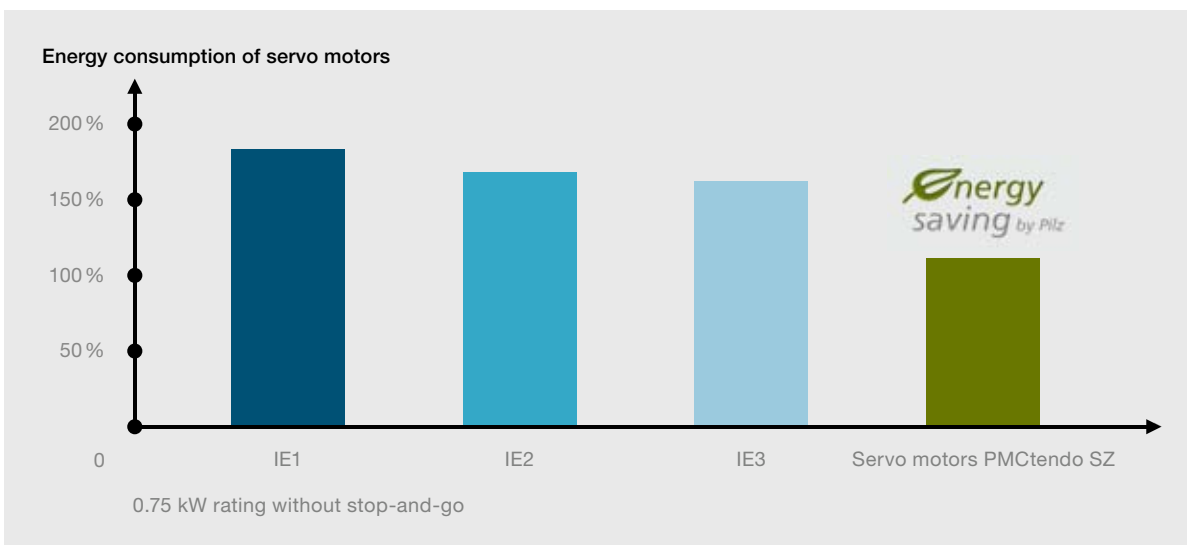

Due to the high efficiency factor, energy saving on servo motors PMCTendo SZ is better than IE4.

► Consulting, engineering and training

As a solution supplier, Pilz can help you to apply optimum safety strategies worldwide. Services encompass the whole machine lifecycle. Our training package with practical, up-to-date course content completes the offering.



Whether the intention is to put a new machine into service, retrofit an existing plant or interlink plant and machinery, the focus is always on safety in all phases of the machine's life. Pilz provides support to companies during the safety-related inspection and when producing the necessary technical documentation. Potential hazard sources are identified, assessed and safely rectified using individual concepts, always in compliance with the relevant standards and directives. This helps to reduce both liability and operating costs.

Our comprehensive range of services also includes an extensive selection of training courses. With safety advice and engineering, a comprehensive and competent service is available over the whole machine lifecycle – from Risk Assessment to System Implementation, Safety Validation and CE Marking.

Services related to machinery safety:

 Webcode 7792

Knowledge gives you a competitive edge – Training from Pilz:



 Webcode 0218

Online information at www.pilz.com



Risk Assessment



Safety Concept



Safety Design



System Implementation



Safety Validation



CE Marking



International Compliance Services



Plant Assessment



Inspection of Safeguarding Devices



Pilz GmbH & Co. KG, Ostfildern, operates an independent inspection body in accordance with DIN EN ISO/IEC 17020:2004 for the plant and machinery sector, accredited by the German Accreditation Body (DAkkS).



Machinery Safety in the Workplace



Seminars on all aspects of machinery safety plus specific product courses

Index

A		F		R	
Angle assignment _____	39	Feedback system _____	8, 22, 29, 31, 40, 42, 56	Real-time Ethernet SafetyNET p _____	29
Application project _____	38, 39	Fieldbus system _____	20, 23	Resolver _____	15, 28, 42
B		Format change _____	28	Risk assessment _____	32, 33, 34, 35, 36, 37, 48, 52
BetrSichV Ind. Safety Regulations _____	64	G		Rotary encoder _____	21, 26
BiSS _____	15, 28	Gearing _____	12, 16, 22, 24, 40, 56	S	
Brake resistor _____	16, 17, 18, 19, 24, 25, 26, 27, 56	H		Safe Brake Control (SBC) _____	13, 31, 35
C		HIPERFACE _____	15, 28, 42	Safe Brake Test (SBT) _____	13, 31, 34, 52, 53
Cable accessories _____	58	I		Safe Direction (SDI) _____	13, 31, 34, 51
Cam editor _____	18, 20	IEC 61131-3 _____	9, 12, 13, 16, 17, 18, 20, 21, 38, 39	Safely Limited Increment (SLI) _____	13, 31, 35
CAN adapter _____	56	IEC 61800-5-2 _____	14, 32, 33, 52	Safely Limited Position (SLP) _____	13, 35
CANopen _____	12, 15, 16, 18, 19, 20, 24, 26, 28, 53, 57	Incremental encoder _____	15, 28	Safely Limited Speed (SLS) _____	13, 31, 34, 35, 52, 53
CoDeSys Target _____	38	Intermediate circuit connection _____	23	Safe motion _____	9, 10, 14, 23, 28, 35, 38, 39, 48, 49, 50, 51, 52, 53, 61
CompactFlash controller-based _____	9, 12, 13, 20	L		Safe Operating Stop (SOS) _____	13, 31, 34, 35, 51
Cycle time _____	8, 11, 13, 14, 15	Linear motor _____	22	Safe Speed Range (SSR) _____	13, 31, 35, 37
D		M		Safe Stop (SS1/SS2) _____	13, 31, 33, 37
DAkKS _____	64	Machinery Directive _____	33, 52	Safe Torque Off (STO) _____	13, 16, 24, 31, 33, 52
DeviceNet _____	15, 28	Mains filter _____	16, 18, 24, 26, 29, 56	SafetyNET p RTFL _____	12, 15
Diagnostic concept PVIS _____	9, 29	Master encoder inputs _____	18, 20, 26	Safe vertical axes _____	48, 49
Drive bus _____	13, 29	Master-Slave relationship _____	39	SD memory card _____	15, 29
Drive configuration _____	8	Memory cell _____	38	Sercos _____	15, 28
Drive-integrated _____	14, 15, 23, 33, 48	Modbus _____	12, 16, 18, 19, 20, 21	Soft PLC _____	9, 16, 18, 20, 38
E		Motion control tools _____	23, 38, 39	Speed _____	22, 41, 44, 45, 46, 63
Editors _____	38	Motor choke _____	23, 56	T	
Electrical cam _____	18, 20	Multi-axis application _____	29	Torque _____	22, 41
Encoder _____	16, 29, 31, 40, 53	P		X	
Encoder interface _____	28	Parameter setting _____	8, 38, 39, 61	x86 Atom processor _____	14
Encoder system _____	41, 63	PAScal _____	36		
EnDat _____	15, 28, 42, 46, 59	PASconfig SDrive _____	38, 39, 53		
EN 12417 _____	50, 51	PDrive _____	39		
EN/IEC 62061 _____	10, 14, 16, 18, 24, 26, 31, 32, 33, 37, 52, 54	PLC function _____	12		
EN ISO 12100 _____	32, 33, 37	PMotion _____	39		
EN ISO 10218-1 _____	50, 51	Position controller _____	16, 24, 26		
EN ISO 13849-1 _____	8, 10, 14, 16, 18, 24, 26, 31, 33, 36, 37, 50, 51, 52, 54	Position encoder emulation _____	16, 24, 26		
EtherCAT _____	15, 24, 26, 27, 28, 53	PROFIBUS-DP _____	12, 15, 16, 18, 19, 20, 21, 24, 26, 28, 53, 57		
Ethernet _____	16, 18, 19, 20, 24, 29	Protection type _____	16, 18, 20, 24, 26, 30, 42		
External brake module _____	31	PScope _____	39		

Contact

AT

Pilz Ges.m.b.H.
Sichere Automation
Modecenterstraße 14
1030 Wien
Austria
Telephone: +43 1 7986263-0
Telefax: +43 1 7986264
E-Mail: pilz@pilz.at
Internet: www.pilz.at

AU

Pilz Australia
Safe Automation
Unit D7, Hallmarc Business park Clayton
Corner of Westall and Centre roads
Clayton, Melbourne, Victoria 3168
Australia
Telephone: +61 3 95446300
Telefax: +61 3 95446311
E-Mail: safety@pilz.com.au
Internet: www.pilz.com.au

BE, LU

Pilz Belgium
Safe Automation
Bijenstraat 4
9051 Gent (Sint-Denijs-Westrem)
Belgium
Telephone: +32 9 3217570
Telefax: +32 9 3217571
E-Mail: info@pilz.be
Internet: www.pilz.be

BR

Pilz do Brasil
Automação Segura
Av. Senador Vergueiro,
347/355 -Jd. do Mar
CEP: 09750-000
São Bernardo do Campo - SP
Brazil
Telephone: +55 11 4126-7290
Telefax: +55 11 4942-7002
E-Mail: pilz@pilz.com.br
Internet: www.pilz.com.br

CA

Pilz Automation Safety Canada L.P.
250 Bayview Drive
Barrie, Ontario
Canada, L4N 4Y8
Telephone: +1 705 481-7459
Telefax: +1 705 481-7469
E-Mail: info@pilz.ca
Internet: www.pilz.ca

CH

Pilz Industrieelektronik GmbH
Gewerbepark Hintermättli
5506 Mägenwil
Switzerland
Telephone: +41 62 88979-30
Telefax: +41 62 88979-40
E-Mail: pilz@pilz.ch
Internet: www.pilz.ch

CN

Pilz Industrial Automation
Trading (Shanghai) Co., Ltd.
Rm. 1702-1704
Yongda International Tower
No. 2277 Long Yang Road
Shanghai 201204
China
Telephone: +86 21 60880878
Telefax: +86 21 60880870
E-Mail: sales@pilz.com.cn
Internet: www.pilz.com.cn

CZ, SK

Pilz Czech s.r.o
Safe Automation
Zelený pruh 1560/99
140 00 Praha 4
Czech Republic
Telephone: +420 222 135353
Telefax: +420 296 374788
E-Mail: info@pilz.cz
Internet: www.pilz.cz

DE

Pilz GmbH & Co. KG
Felix-Wankel-Straße 2
73760 Ostfildern
Germany
Telephone: +49 711 3409-0
Telefax: +49 711 3409-133
E-Mail: info@pilz.de
Internet: www.pilz.de

DK

Pilz Skandinavien K/S
Safe Automation
Ellegaardvej 25 L
6400 Sønderborg
Denmark
Telephone: +45 74436332
Telefax: +45 74436342
E-Mail: pilz@pilz.dk
Internet: www.pilz.dk

ES

Pilz Industrieelektronik S.L.
Safe Automation
Camí Ral, 130
Polígono Industrial Palou Nord
08401 Granollers
Spain
Telephone: +34 938497433
Telefax: +34 938497544
E-Mail: pilz@pilz.es
Internet: www.pilz.es

FI

Pilz Skandinavien K/S
Safe Automation
Nuijamiestentie 7
00400 Helsinki
Finland
Telephone: +358 10 3224030
Telefax: +358 9 27093709
E-Mail: pilz.fi@pilz.dk
Internet: www.pilz.fi

FR

Pilz France Electronic
1, rue Jacob Mayer
CS 80012
67037 Strasbourg Cedex 2
France
Telephone: +33 3 88104000
Telefax: +33 3 88108000
E-Mail: siege@pilz-france.fr
Internet: www.pilz.fr

GB

Pilz Automation Ltd
Pilz House
Little Colliers Field
Corby, Northants
NN18 8TJ
United Kingdom
Telephone: +44 1536 460766
Telefax: +44 1536 460866
E-Mail: sales@pilz.co.uk
Internet: www.pilz.co.uk

IE

Pilz Ireland Industrial Automation
Cork Business and Technology Park
Model Farm Road
Cork
Ireland
Telephone: +353 21 4346535
Telefax: +353 21 4804994
E-Mail: sales@pilz.ie
Internet: www.pilz.ie

In many countries we are represented by sales partners. Please refer to our homepage www.pilz.com for further details or contact our headquarters.

Contact

IN

Pilz India Pvt Ltd.
Office No 202, Delite Square
Near Aranyeshwar Temple
Sahakar Nagar No 1
Pune 411009
India
Telephone: +91 20 2421399-4/-5
Telefax: +91 20 2421399-6
E-Mail: info@pilz.in
Internet: www.pilz.in

IT

Pilz Italia S.r.l.
Automazione sicura
Via Gran Sasso n. 1
20823 Lentate sul Seveso (MB)
Italy
Telephone: +39 0362 1826711
Telefax: +39 0362 1826755
E-Mail: info@pilz.it
Internet: www.pilz.it

JP

Pilz Japan Co., Ltd.
Safe Automation
Ichigo Shin-Yokohama Bldg. 4F
3-17-5 Shin-Yokohama
Kohoku-ku
222-0033 Yokohama
Japan
Telephone: +81 45 471-2281
Telefax: +81 45 471-2283
E-Mail: pilz@pilz.co.jp
Internet: www.pilz.jp

KR

Pilz Korea Ltd.
Safe Automation
22F Keumkang
Pentierum IT Tower Unit B
810 Gwanyang-dong, Dongan-gu
Anyang-si, Gyeonggi-do, 431-060
South Korea
Telephone: +82 31 450 0677
Telefax: +82 31 450 0670
E-Mail: info@pilzkorea.co.kr
Internet: www.pilz.co.kr

MX

Pilz de México, S. de R.L. de C.V.
Automatización Segura
Convento de Actopan 36
Jardines de Santa Mónica
Tlalnepantla, Méx. 54050
Mexico
Telephone: +52 55 5572 1300
Telefax: +52 55 5572 1300
E-Mail: info@pilz.com.mx
Internet: www.pilz.mx

NL

Pilz Nederland
Veilige automatisering
Havenweg 22
4131 NM Vianen
Netherlands
Telephone: +31 347 320477
Telefax: +31 347 320485
E-Mail: info@pilz.nl
Internet: www.pilz.nl

NZ

Pilz New Zealand
Safe Automation
Unit 4, 12 Laidlaw Way
East Tamaki
Auckland 2016
New Zealand
Telephone: +64 9 6345350
Telefax: +64 9 6345352
E-Mail: office@pilz.co.nz
Internet: www.pilz.co.nz

PL

Pilz Polska Sp. z o.o.
Safe Automation
ul. Ruchliwa 15
02-182 Warszawa
Poland
Telephone: +48 22 8847100
Telefax: +48 22 8847109
E-Mail: info@pilz.pl
Internet: www.pilz.pl

PT

Pilz Industrieelektronik S.L.
R. Eng Duarte Pacheco, 120
4 Andar Sala 21
4470-174 Maia
Portugal
Telephone: +351 229407594
Telefax: +351 229407595
E-Mail: pilz@pilz.pt
Internet: www.pilz.pt

RU

Pilz RUS OOO
Ugreshskaya street, 2,
bldg. 11, office 16 (1st floor)
115088 Moskau
Russian Federation
Telephone: +7 495 665 4993
E-Mail: pilz@pilzrussia.ru
Internet: www.pilzrussia.ru

SE

Pilz Skandinavien K/S
Safe Automation
Energigatan 10 B
43437 Kungsbacka
Sweden
Telephone: +46 300 13990
Telefax: +46 300 30740
E-Mail: pilz.se@pilz.dk
Internet: www.pilz.se

TR

Pilz Emniyet Otomasyon
Ürünleri ve Hizmetleri Tic. Ltd. Şti.
Kayışdağı Cd. Beykonağı Plaza
No:130 K:2 D:2
Ataşehir/İstanbul
Turkey
Telephone: +90 216 5775550
Telefax: +90 216 5775549
E-Mail: info@pilz.com.tr
Internet: www.pilz.com.tr

TW

Pilz Taiwan Ltd.
7F.-3, No. 146, Songjiang Rd.
Zhongshan Dist., Taipei City
104, Taiwan
Telephone: +886 2 2568 1680
Telefax: +886 2 2568 1600
E-Mail: info@pilz.tw
Internet: www.pilz.tw

US

Pilz Automation Safety L.P.
7150 Commerce Boulevard
Canton
Michigan 48187
USA
Telephone: +1 734 354 0272
Telefax: +1 734 354 3355
E-Mail: info@pilzusa.com
Internet: www.pilz.us

In many countries we are represented by sales partners. Please refer to our homepage www.pilz.com for further details or contact our headquarters.

► Support

Technical support is available from Pilz round the clock.

Americas

Brazil
+55 11 97569-2804

Canada
+1 888-315-PILZ (315-7459)

Mexico
+52 55 5572 1300

USA (toll-free)
+1 877-PILZUSA (745-9872)

Asia

China
+86 21 60880878-216

Japan
+81 45 471-2281

South Korea
+82 31 450 0680

Australia

+61 3 95446300

Europe

Austria
+43 1 7986263-0

Belgium, Luxembourg
+32 9 3217575

France
+33 3 88104000

Germany
+49 711 3409-444

Ireland
+353 21 4804983

Italy
+39 0362 1826711

Scandinavia

+45 74436332

Spain

+34 938497433

Switzerland

+41 62 88979-30

The Netherlands

+31 347 320477

Turkey

+90 216 5775552

United Kingdom

+44 1536 462203

You can reach our international hotline on:

+49 711 3409-444
support@pilz.com

Pilz develops environmentally-friendly products using ecological materials and energy-saving technologies. Offices and production facilities are ecologically designed, environmentally-aware and energy-saving. So Pilz offers sustainability, plus the security of using energy-efficient products and environmentally-friendly solutions.

Energy saving by Pilz



The 4-fold safety of automation



Presented by:



Pilz GmbH & Co. KG
Felix-Wankel-Straße 2
73760 Ostfildern, Germany
Tel.: +49 711 3409-0
Fax: +49 711 3409-133
info@pilz.com
www.pilz.com

pilz
the spirit of safety