

MODULAR CONCEPT

02	SERVICE & QUALITY
08	STANDARD BELLOWS
18	SAUIMRAI BELLOWS
26	SPECIAL BELLOWS
34	BACKWALL SYSTEMS
38	GLADIATOR STEEL COVERS
46	ROLLER SYSTEMS
58	DURASPRING SPIRAL SPRINGS
68	WINDOW SYSTEMS

MACHINE SAFETY WINDOWS

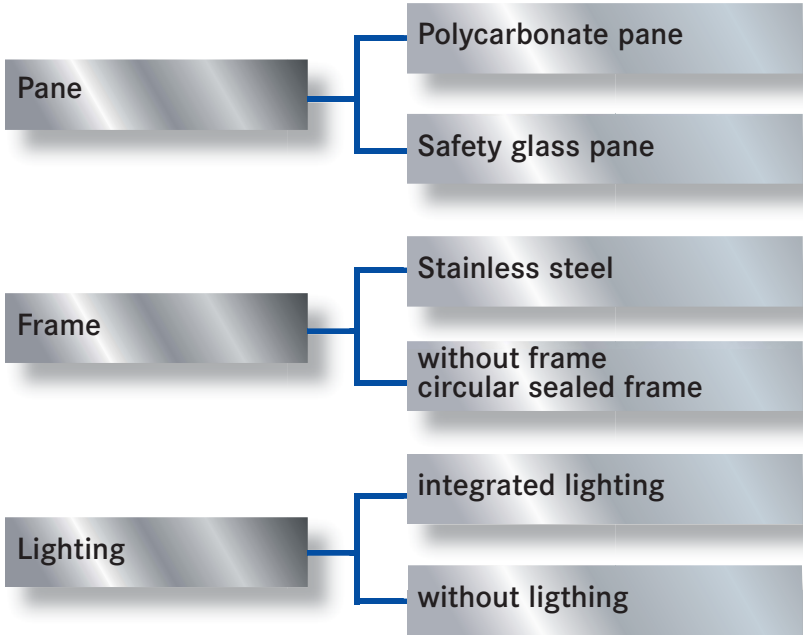

VISIPOINT® SPIN WINDOWS

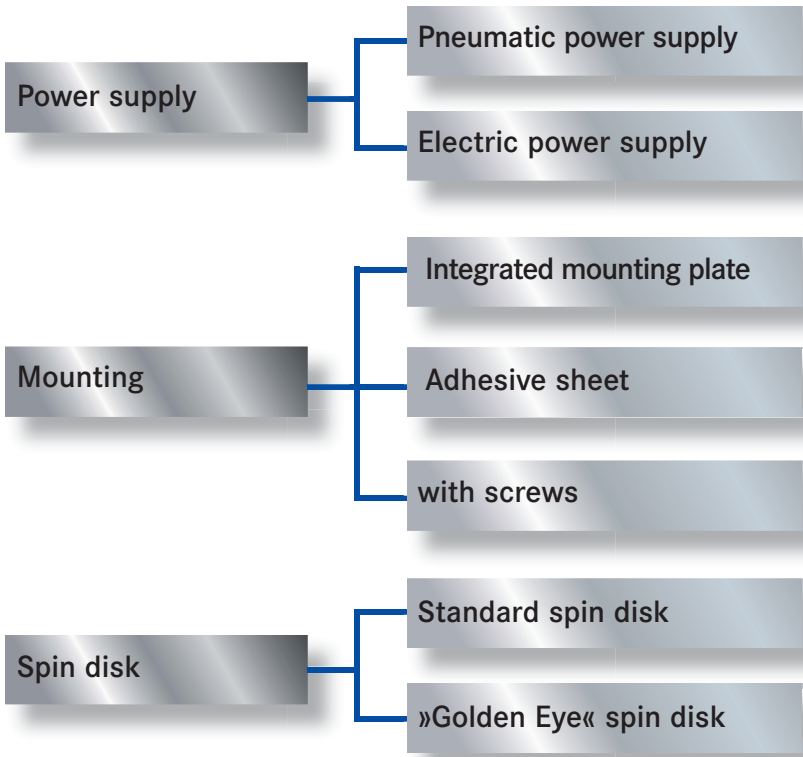

MACHINE SAFETY WINDOWS

Safety glass is a restraining protective device on machining centres. It prevents tools, machined parts and broken particles from being ejected out of the machine's working space and protects people from injuries.

Industrial accident statistics show that workers are still the frequent victims of flying objects ejected by machine tools. Viewing panes in machining centres, ideally combined with a spin window system, provide a good view for the operator and transparency of the manufacturing process.

Viewing panes within the trajectory path of parts must exhibit adequate strength. According to the latest empirical tests polycarbonate is the material best suited for safety glass owing to its high energy absorption.

The restraining capacity of a polycarbonate pane of 8 mm thickness is about the same as of a 3 mm St 12.03 sheet.

Application	Protection against
Turning	<ul style="list-style-type: none"> ■ broken chuck components ■ broken tools ■ machine parts
Milling	<ul style="list-style-type: none"> ■ hot chips ■ broken tools ■ machine parts
Grinding	<ul style="list-style-type: none"> ■ Pieces of broken grinding disks

Application areas of safety windows

A disadvantage of polycarbonate is its sensitivity to scratching and it will be damaged by the impact of hot chips and sparks.

Furthermore it has low resistance to the effects of coolants, grease and oil and will embrittle as a result. This can reduce the restraining capacity within just a few years.

The safety glass provided by HEMA is encapsulated and sealed for permanent and efficient protection against these external influences.

Any safety glass showing damage from external mechanical impact, for example cracks, deep scratches or deterioration resulting from exposure to chemicals, must be replaced if it is to continue functioning properly.

At present there are three technical standards for metal cutting tools: DIN EN 23125 (for lathes), DIN EN 13128 and DIN EN 12417 (for milling machines and machining centres). These standards form the basis of our safety glass and spin window systems. You may determine the relevant safety classification and the corresponding minimum thickness of the polycarbonate from the tables on the following pages. The influential factors are the mass of the tool and of the machined part and the speed of rotation.



Machine safety window with stainless steel frame, including mounted VISIPORT® with »Golden Eye« spin disk

The restraining capacity of safety glass depends not only on the thickness of the polycarbonate but also on the sheet metal design of its enclosure. Clamps or bonding or an adequate frame is the best solution for the mounting.

The joints should be well covered to prevent the screen from being pushed through the frame when impacted by parts.



Machine safety window, standard design

SERVICE & QUALITY 02

STANDARD BELLOWS 08

SAUWRAI BELLOWS 18

SPECIAL BELLOWS 26

BACKWALL SYSTEMS 36

GLADIATOR STEEL COVERS 38

ROLLER SYSTEMS 46

DURASPRING SPIRAL SPRINGS 58

WINDOW SYSTEMS 69

IMPACT TEST

Safety glass is a restraining protective device on machining centres. As part of tests on their restraining ability a range of HEMA polycarbonate panes with and without integrated VISIPOINT® mounting plate were tested at the IWF of TU Berlin.



Fixing of pane

For the impact test according to DIN EN 23125, resistance class C3, for example, panes with 10 mm tempered safety glass and 15 mm polycarbonate were tested with and without supporting mountig plate for VISIPOINT®.

Testing

Polycarbonate panes are fixed within a frame and impacted with a 2.5 kg projectile.

The speed of the projectile is adjusted at the cannon's pressure, the speed is measured with a double laser light barrier.

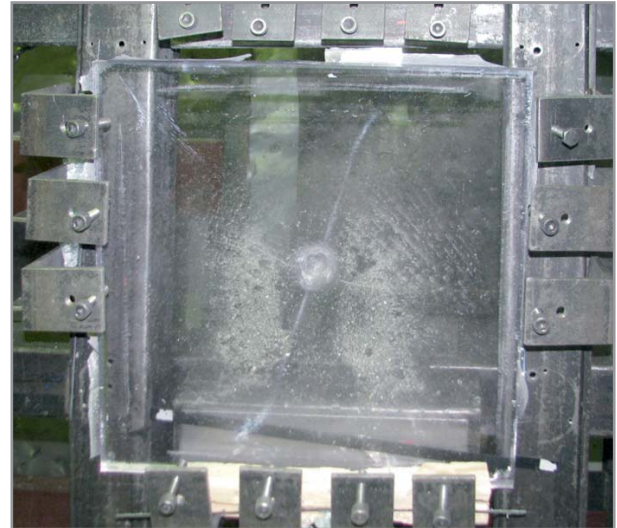

Fixed polycarbonate pane after impact test

Test No	Test object	Projectile speed v [m/s]	Projectile energy E [Nm]	Result, note
1	4e	80	8000	passed
2	4b	80	8000	passed
3	4c	80	8000	passed
4	4f	80	8000	passed

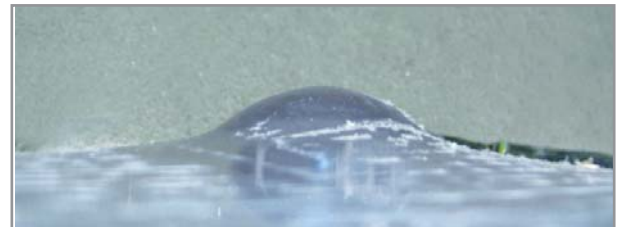

Ident of polycarbonate pane after impact test



Panorama view of test laboratory at the IWF of TU Berlin. In the foreground acceleration pipe with projectile (enlarged).

Quelle: IWF

MACHINE SAFETY WINDOWS

Material / classification	A1	A2	A3	B1	B2	B3	C1	C2	C3
Mass of projectile in kg	0.625	0.625	0.625	1.25	1.25	1.25	2.50	2.50	2,50
Kinetic energy in joule	320	781	2000	1562	2480	4000	3124	4960	8000
PC 6 mm	■			■					
PC 8 mm	■	■		■	■		■		
PC 10 mm	■	■	■	■	■		■	■	
PC 12 mm	■	■	■	■	■	■	■	■	
PC 15 mm	■	■	■	■	■	■	■	■	■
PC 19 mm laminated	■	■	■	■	■	■	■	■	■

Impact tests according to DIN EN 23125 at test pattern 500 x 500 mm

■ Available combination (without guarantee)

Parameter for calculation of safety classification and thickness of polycarbonate panes for turning centres according DIN EN 23125

Diameter of rotation	Maximum outer diameter of the clamping jaw at the machine
Rotational speed of the spindle	Maximum speed of the machine according to the manufacturer
Mass of clamping jaw	Mass of one clamping jaw (classification according to proposed standard)

max. diameter of clamping jaw (mm)	circumferential speed v (m/s)	Projectile dim. D x a (mm x mm)	Projectile mass m (kg)	Impact speed v (m/s), up to	Impact energy (Nm), up to	safety classification*	Minimum thickness of PC (mm)
up to 130	25	30 x 19	0.625	32	320	A1	6
	40			781	A2	6	
	63			2.000	A3	8	
130 to 250	40	40 x 25	1.250	50	1,562	B1	6
	50			2,480	B2	8	
	63			4,000	B3	12	
> 250	40	50 x 30	2.500	50	3,124	C1	8
	50			4,960	C2	10	
	63			8,000	C3	15	

*A1 to C3 = Classification according DIN EN 23125; PK 1 to 5 = classification according to VDW

SERVICE & QUALITY	02
STANDARD BELLOWS	08
SAUWRAI BELLOWS	18
SPECIAL BELLOWS	26
BACKWALL SYSTEMS	36
GLADIATOR STEEL COVERS	38
ROLLER SYSTEMS	46
DURASPRING SPIRAL SPRINGS	58
WINDOW SYSTEMS	71

MACHINE SAFETY WINDOWS

Calculation of safety classification and required polycarbonate thickness for milling machines DIN EN 12417

02	SERVICE & QUALITY	Diameter of rotation	maximum outer diameter of the cutting tool unit at the machine concerned
		Rotation speed of spindle	maximum speed of the machine according to the manufacturer
08	STANDARD BELLOWS	Mass of cutting tool	mass of cutting tool, defined for 100 g according to proposed standard

Required Data for calculation of impact energy and impact speed

Projectile mass m (kg)	impact speed vt (m/s), up to	impact energy (Nm), up to	Minimal thickness of Polycarbonate (mm)
0.100	85	361	4
0.100	100	500	6
0.100	120	720	8
0.100	145	1.063	10
0.100	150	1.125	12
0.100	170	1.445	15
0.100	>170	>1.445	19

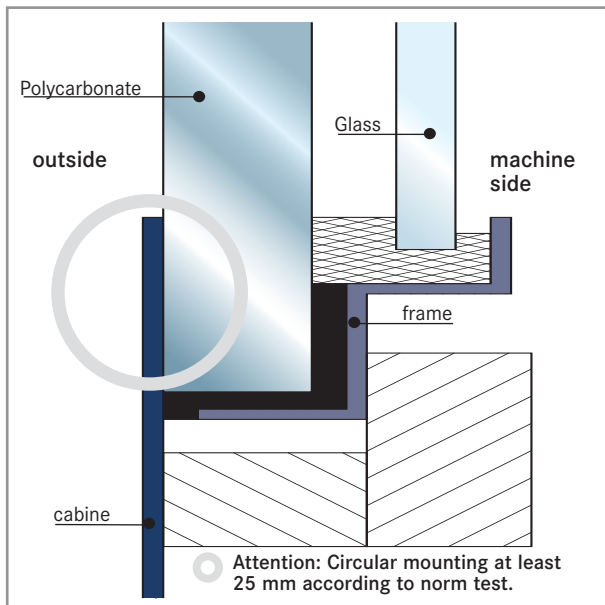

Design of safety glass window

Polycarbonate panes only with safety foil

When exposed these polycarbonate panes may lose their safety restraining properties partly or completely after only a few months of use.

This was impressively demonstrated by tests at the BIA Institute. Systematic research showed that polycarbonate panes splashed with coolant possess a retaining potential of only 60% after nine months of exposure.

According to our definition safety glass may be considered exposed as long as it is not completely encapsulated by an additional glass layer or a special foil. This encapsulation and sealing can be verified only by specialised companies.

In spite of the lower safety classification requirements of milling/drilling machine manufacturers and polycarbonate pane thicknesses less than 6 mm customers still use these panes.

Although the pane thickness corresponds to the machine's safety classification these panes are unprotected, i.e. not encapsulated or sealed.

Polycarbonate panes for machines should be protected against chemical attacks if they are to provide reliable protection over the long term.

A special focus of attention is the safety risks posed by safety windows that has found testimony over recent years.

The replacement of unprotected polycarbonate panes is recommended by VDMA (association of German machine and plant manufacturers) after only two years of use.

The safety glass fulfils the applicable recommendations of VDMA for an assured A1 to C3 safety classification. It is non-aging and resistant to oil, coolants, and heavy impacts.

MACHINE SAFETY WINDOWS

The increasing imports of machining centres from low-cost countries always mean a safety risk, and the legal requirements are not always being met by these products.

Safe operation can be achieved though when these low cost machines are retrofitted in accordance with the required European safety standards.

Recommendation for replacement of panes

According to the recommendations of the German Berufsgenossenschaft BIA (Accident Prevention & Insurance Association), the Werkzeugmaschinenverband VDW, and the IWF/TU Berlin, Fachgebiet Werkzeugmaschinen und Fertigungstechnik, we recommend that protective panes are replaced after 5 years of use.

All buyers of new or second-hand machine tools must be informed of polycarbonate deterioration (e.g. in the manual). It is also recommended to mark the installation date of the polycarbonate pane on the pane itself. Replacing and servicing protection panes must observe all of the instructions from the manufacturer.

We recommend replacing the pane immediately when there is:

- deformation and/or cracks from impacts
- damage to the sealing
- infiltration of cooling fluid
- damage or destruction to the protection pane (or the scratch-resistant protection film) on the operator or machine side

HEMA safety windows

- Only certified quality panes of polycarbonate are used with an efficient surface coating providing protection against chemicals, abrasion and scratching, film on option
- Polycarbonate panes from renowned manufactures
- Polycarbonate panes can be provided with any of the usual thicknesses. The basic versions range from 5 to 15 mm in thickness.
- PC panes are protected on the machine side by an additional single or multiple layer safety glass pane.
- The design may consist of polycarbonate with abrasion-proof coating and glass depending on customer requirements.
- Splinter proof laminated glass with a low risk of injury and for shorter cleaning and machine downtimes.
- The edges of the panes are completely sealed and resistant to coolants. In addition they can be fitted with stainless steel frame for optimal mounting.
- The panes and their components are tested by the IWF institute in Berlin according to DIN EN 23125, restraint categories A1 to C3, and to safety standards CEN/TC 143/WG3
- The customer receives a 5-year warranty on the encapsulated and sealed safety pane (according to our warranty conditions).

- The integration of modern spin window solutions such as VISIPORT® is possible without any safety risk or additional mounting work.

Design of machine safety windows

»HEMA WINDOW« machine safety windows are suitable for most applications. They can be produced with optional graduation, protection films, steel frames. Also the integration of LED lighting is possible (see page 74).

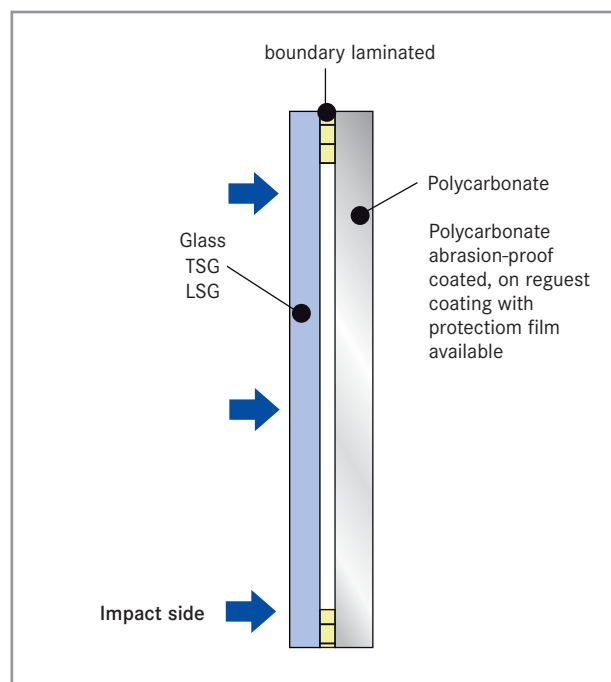

Design of machine safety window

The thickness of polycarbonate and the design of the multi-layer machine safety window is based on the individual requirements and safety classifications. The HEMA charge number system assures traceability and convenient re-ordering.



Label inside window

SERVICE & QUALITY	02
STANDARD BELLOWS	08
SAUWRAI BELLOWS	18
SPECIAL BELLOWS	26
BACKWALL SYSTEMS	36
GLADIATOR STEEL COVERS	38
ROLLER SYSTEMS	46
DURASPRING SPIRAL SPRINGS	58
WINDOW SYSTEMS	73

MACHINE SAFETY WINDOW WITH INTEGRATED LIGHTING

Machine safety windows permit safe viewing of machining operations inside the machine tool. Most often there is a need for additional lighting. Depending on available space and position, conventional lights can become dulled by accumulation of swarf and contamination by coolant.

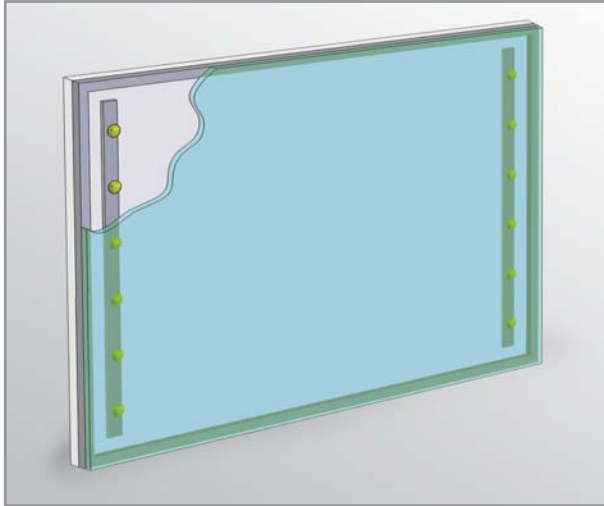

Machine safety window with LED lighting

The optimum solution combines a clear view into the machine with suitable lighting. This solution is available in the form of illuminated HEMA Windows - the integration of LED technology in a machine safety window. These illuminated safety windows combine the advantages of two established systems in one compact solution. The variable position of the LED lighting rails - vertical or horizontal - enables a flexible fitting to requirements of the machine interior. Problems of swarf and coolant contamination of internally mounted lamps will be eliminated.

The well proven perimeter seal design ensures the LED's and internal surfaces are protected from ingress of contamination and moisture.



Machine safety window with LED lighting

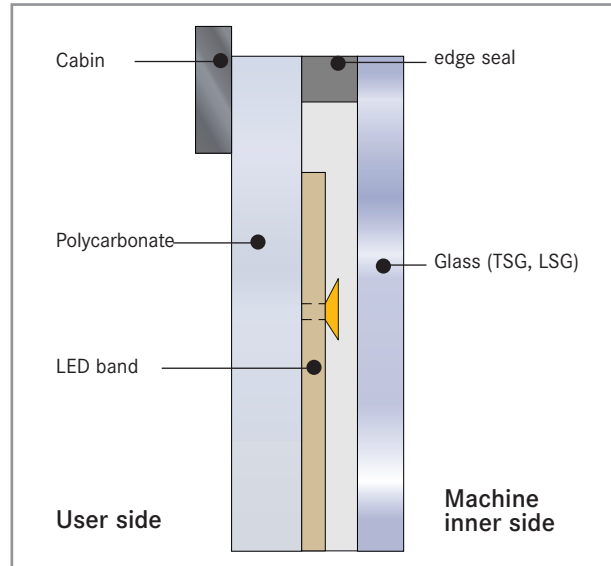

Layout of the safety window with integrated lighting

The advantages of HEMA windows with integrated lighting:

- Compact system solution
- Flexible illumination of the machine interior
- Tried and tested LED technology
- Elimination of lamp contamination
- Power supply from the mains or the machine
- Retrofit option on machines

Types

Power supply	24 VDC
Current	270 mA, 540 mA, 800 mA, 1100 mA, 2160mA
Operating voltage	6 W / 12 W / 18 W / 24 W / 48 W
Lens	ca. 120°
Light temperature	5700 K
Connection	M12

Due to the complex plug-in system the LED modules can be reused when the machine window is damaged.

The »SECRET« LED modules are also **available individually for other applications**. Our service will be happy to assist you.



HEMA »SECRET« LED modules

VISIPOINT® SPIN WINDOWS

VISIPOINT® Spin Windows are suitable for all types of CNC milling machines, lathes and machining centres, either retro-fitted or integrated at the factory.

The modular design facilitates installation and optimises maintenance for reduced costs.



VISIPOINT® 220C2

With their low weight and a generous visible surface, VISIPOINT® can be adapted optimally to your machines. Additional electronic safety features complete the perfect impression.

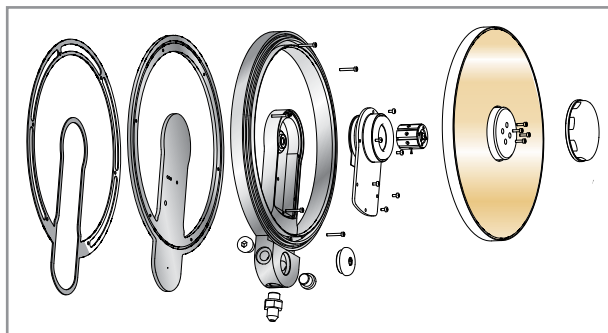

Diagram of VISIPOINT®

Complete solutions - Safety Windows with mounted VISIPOINT® Spin Windows are also available. They are ready to mount without extra effort.

These systems can be preconfigured and then only have to be installed and connected. All systems meet the respective security requirements.

Advantages of VISIPOINT® Spin Windows

VISIPOINT® is synonymous with active safety precautions: Without VISIPOINT®, the operator can be tempted to bypass the safety circuit of the machine to see what is happening in the machine - potential danger with serious consequences!

With regard to product liability and safety regulations, take a look at the safety advantages of VISIPOINT® - it could pay off.



Direct view of the machining process

Installation and fixing

No hole has to be drilled in the machine cabin. The unit is either fastened on the bonded mounting plate or bonded directly to the window. The mounting plate allows fast replacement of the VISIPOINT® unit. VISIPOINT® can be installed vertically and up to 30° from the vertical. The flat construction enables the VISIPOINT® to be adapted to widely differing door and window designs. VISIPOINT® is also suitable for fastening to sliding doors with limited intermediate space. VISIPOINT® can be fixed in different ways:

- bonded
- screwed to safety window
- screwed directly to the integrated mounting plate

Bonding

The VISIPOINT® is mounted easily with a high-tech adhesive sheet (adhesive based on closed cellular acrylic foam). Simply remove the protective foil on the rear side of the VISIPOINT® and bond the VISIPOINT® to the desired position on the pane which should be cleaned thoroughly beforehand. The optimal setting time is 72 hours. To speed up installation we offer a special vacuum pump, which reduces the bonding time to 1-2 hours (95% bonding strength). Applying heat to the mounting frame can also help to reduce the bonding time. Afterwards it is very difficult to separate the VISIPOINT® from the surface it is bonded to, provided the surface had been cleaned adequately beforehand.



VISIPOINT® with high-tech adhesive sheet

SERVICE & QUALITY 02

STANDARD BELLOWS 08

SAUWRAI BELLOWS 18

SPECIAL BELLOWS 26

BACKWALL SYSTEMS 36

GLADIATOR STEEL COVERS 38

ROLLER SYSTEMS 46

DURASPRING SPIRAL SPRINGS 58

WINDOW SYSTEMS 75

VISIPOINT® SPIN WINDOWS

Screwed to safety window

In this case six holes are drilled through the polycarbonate pane (a process that degrades the pane's resistance). The holes are sealed from the machine's cabin side with an integrated o-ring. On the control side VISIPOINT® is fixed in place with a screwed clamping flange

Machine safety windows with integrated mounting plate

The easiest solution is to secure the VISIPOINT® to the mounting plate already integrated within the safety window. VISIPOINT® only has to be positioned and secured in place with the enclosed screws.



Machine safety window with integrated mounting plate

VISIPOINT® ventilation and airing

VISIPOINT® has a patented system with a separate flexible hose that supplies the required quantity of air for the interior ventilation of the VISIPOINT®.

The flexible hose protects the wire harness between the VISIPOINT® and the connecting box. Air circulation is important. Ventilation should always be assured.

Power supply

VISIPOINT® is available with two different drives types. VISIPOINT® 220C2 is equipped with an electrical drive, DiscAir 180 Turbo with a pneumatic drive.

Coolant

VISIPOINT® functions best with water based coolants and mineral oils; other oils on request.

For oil emulsion coolants we recommend the specially coated »Golden Eye« spin disk.

»Golden Eye« special disk

Machining aluminium or magnesium generates chips which condense like a film on the pane and the spin disk. This problem leads to obscured vision after only a short time. For these applications we recommend fitting the VISIPOINT® with the »Golden Eye« spin disk.

Its special coating gives the disk a gold coloured tint. This coating underwent exhaustive testing for 18 months under severe conditions in the mechanical production facilities at Boeing in Seattle.

VISIPOINT® models 180.B5, 220.B5 and 220C2 with electric drive can be retrofitted or fitted directly with the »Golden Eye« spin disk when ordered.

The Disc Air 180 Turbo is fitted as standard with a »Golden Eye« coated spin disk.

Product quality

All VISIPOINT® models come with a twelve month warranty ex works. Wearing parts are excluded. Many components are made of high-grade aluminium.

The ball bearings are lubricated for life and can be replaced. The flexible metal connecting hose or the tube system is temperature resistant up to 300°C.

The electronic components were developed specifically for the VISIPOINT®.

Ambient influences are excluded by the optimum installation position and sealing.

All parts and components of the VISIPOINT® are tested for material quality and life endurance.

Model	VISIPOINT® 220C2	VISIPOINT® DiscAir 180 Turbo
Required voltage	24V (± 1V), min. 5A continuous load	-
Required air pressure	-	5.3 - 5.8 bar
Speed	2.235 rpm	4000 rpm (at 5.5 Bar)
Air consumption	-	38 l/min
Noise level	-	79 dB (without housing, at a distance of 3 m)
Diagonal dimension/total dimension	253 mm / 299 mm	201,7 / 236,2 mm
Viewing area	215 mm	175 mm
Weight	2.1 kg	0.7 kg
Height	32.5 mm / 43 mm	29.6 mm / 44.9 mm
Thickness of disk	3 mm	2 mm
Golden-Eye disk	optional	standard

VISIPOINT® 220C2

VISIPOINT® 220C2

- Spinning disk mounted in the machine side, providing a clear view of the process through its high rotary speed (> 2,235 rpm)
- Integrated, protected electronic control unit providing protection against reverse and overvoltage, thermo circuit protecting against overheating (150°C)
- Driven by integrated brushless DC motor; power supply
- Fulfils CE standards for low tension voltage
- low weight, only about 2.1 kg
- built-in chip protection with specially designed base and disc ring
- Balanced rotating disc made of hardened glass 3 mm thick
- Optional plasma coated »Golden Eye« version

Connection

The VISIPOINT® 220C2 provides a three-way connection on its base plate:

- Connection fitting for FLEX metal hose
- FESTO fast connection fitting for FESTO tubes 8 x 1.25 mm
- EO fitting for Ø 8, 10 or 12 mm metal pipes
- Connection fitting EH-PG09 for plastic cable tube EW-PA-M12/P9



Variations of VISIPOINT® 220C2

FDX	Basic model, direct screw coupling on polycarbonate panes
FMX	Basic model, with VHB adhesive tape on basic device
FVX	Basic model, VHB adhesive tape on extra mounting plate for easy replacement
HM	Basic model, separate terminal box, VHB adhesive tape on basic device
HV	Basic model with terminal box and VHB adhesive tape on separate mounting plate for easy replacement

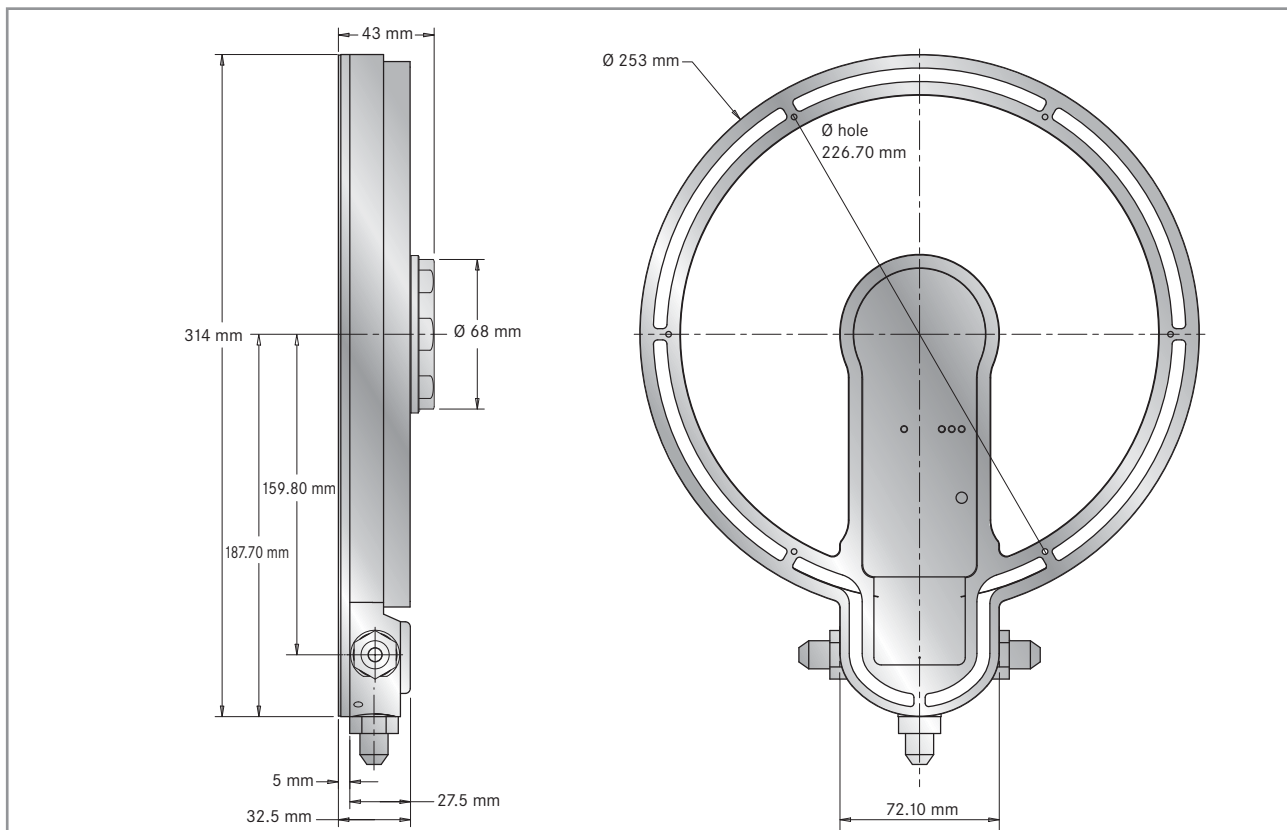

VISIPOINT® DISCAIR 180 TURBO

VISIPOINT® DiscAir 180 Turbo

- Spin disk located on the machine side, providing clear view of machining through its high rotating speed (> 4000 rpm)
- Driven by purified compressed air, no electrical connection required
- Suitable for use with intermittent coolant spraying
- Rotor mounted on precision ball bearing
- Balanced rotating disc made of hardened glass 2 mm thick
- Plasma coated »Golden Eye« disk as standard
- Air hose connected at plug-in socket
- Patented high efficient turbine ring
- Air consumption 38 l/min

Connection

The DiscAir model is driven with compressed air available at almost every machine or at every workshop: simply connect the VISIPOINT® DiscAir to the compressed air supply - without costly electric wiring.

It is secured in place on the machine pane with simple fasteners, similarly to the electric VISIPOINT®.

Due to its design and drive the DiscAir model generates more noise than the extremely low noise electrical VISIPOINT® Model. Owing to its optimised air circulation system and high precision manufacturing process the DiscAir model is nevertheless quite and fulfils the legal directives.



So there is very little difference to the machine's own noise levels when the cabin door is closed.

The air outlet has been designed to provide additional protection against the intrusion of coolant and chips.

The VISIPOINT® DiscAir model rounds off the VISIPOINT® line and represents an excellent price to performance ratio. It enables every CNC machine operator to adopt the spin window technology at a price considerably lower than that of electrical models.

