

# SINEAX F535

## Transducer for measuring frequency difference

Carrying rail housing P13/70

### Application

The transducer **SINEAX F535** (Fig. 1) converts the frequency difference of two synchronised supplies into a **load independent** DC current or a **load independent** DC voltage proportional to the measured value.

The transducer fulfils all the important requirements and regulations concerning electromagnetic compatibility **EMC** and **Safety** (IEC 1010 resp. EN 61 010). It was developed and is manufactured and tested in strict accordance with the **quality assurance standard** ISO 9001.



Fig. 1. Transducer SINEAX F535 in housing P13/70 clipped onto a top-hat rail.

### Features / Benefits

- **Measuring inputs:** Sine, rectangular, or distorted wave forms of nominal input voltages with dominant fundamental waves

Measured variables	Nominal input voltages	Measuring range limits
Frequency difference	10 to 690 V	$\Delta = \pm 1\% f_s$ to $\pm 80\% f_s$ $f_s$ and $f_G$ 10 Hz to 1.5 kHz

- **Measuring output:** Unipolar, bipolar or live zero output variables
- **Measuring principle:** Digital period measurement
- **AC/DC power supply / Universal**
- **Standard as marine version per Lloyd's Register of Shipping**

### Technical data

#### General

Measured quantity: Frequency difference  $\Delta f$   
 Measuring principle: Digital period measurement

#### Measuring inputs $\rightarrow$

Measuring range ( $f_s$  = bus bar,  $f_G$  = generator): See Section "Specification and ordering information"

Nominal input voltages  $U_N$ : Generator and bus bar  
 10 ... 230 V or 230 ... 690 V  
 (max. 230 V with power supply from voltage measuring input)

Own consumption:  $< U_N \cdot 1.5$  mA per measuring input

Overload capacity:

Measured quantities $U_N$	Number of applications	Duration of one application	Interval between two successive applications
$1.2 \times U_N^1$	—	continuously	—
$2 \times U_N^1$	10	1 s	10 s

<sup>1</sup> But max. 264 V with power supply from voltage measuring input

Wave form: Any; fundamental wave only taken into account

#### Measuring output $\rightarrow$

Load independent DC current: 0 ... 1 to 0 ... 20 mA  
 resp. live-zero  
 1 ... 5 to 4 ... 20 mA  
 $\pm 1$  to  $\pm 20$  mA

Burden voltage: + 15 V, resp. - 12 V

Load independent DC voltage: 0 ... 1 to 0 ... 10 V  
 resp. live-zero  
 0.2 ... 1 to 2 ... 10 V  
 $\pm 1$  to  $\pm 10$  V

Load capacity: Max. 4 mA

Voltage limit under  $R_{ext} = \infty$ :  $\leq 25$  V

# SINEAX F535

## Transducer for measuring frequency difference

Current limit under overload:

Approx.  $1.3 \times I_{AN}$  at current output  
Approx. 30 mA at voltage output

Residual ripple in output current:

< 0.5% p.p.

Nominal value of response time:

4 periods of the measuring frequency

Other ranges:

2, 8 or 16 periods of the measuring frequency

Behaviour of output current in different operating states:

Operating state <sup>1</sup>		Output	Display
Generator frequency	Bus frequency		
$f_G > f_s$		unipolar	$> I_{AN} / 2$
		bipolar	positive
missing <sup>2</sup>	nominal value	unipolar	approx. 0
		bipolar	approx. $-110\% I_{AN}$
nominal value	missing <sup>2</sup>	unipolar	approx. $+110\% I_{AN}$
		bipolar	
missing <sup>2</sup>	missing <sup>2</sup>	unipolar	approx. $I_{AN} / 2$
		bipolar	approx. 0

<sup>1</sup> With power supply switched on

<sup>2</sup> E.g. switched off or fault condition

### Accuracy (acc. to EN 60 688)

Reference value: Output span

Basic accuracy: Class 0.2

### Reference conditions

Ambient temperature: 15 ... 30 °C

Input voltage:  $U_{min}$  to  $U_{max}$

Distortion factor: No influence

Power supply: At nominal range

Output burden:  $\Delta R_{ext}$  max.

### Safety

Protection class: II (protection isolated, EN 61 010)

Housing protection: IP 40, housing (test wire, EN 60 529)  
IP 20, terminals (test finger, EN 60 529)

Contamination level: 2

Overvoltage category: III

Rated insulation voltage (against earth): 230 resp. 400 V, input  
230 V, power supply  
40 V, output

Test voltage: 50 Hz, 1 min. acc. to EN 61 010-1  
3700 resp. 5550 V, input versus all other circuits as well as outer surface  
3700 V, power supply versus output as well as outer surface  
490 V, output versus outer surface

### Power supply →○

AC/DC power pack (DC or 50/60 Hz)

Table 1: Rated voltages and permissible variations

Rated voltage	Tolerance
85 ... 230 V DC, AC	DC – 15 ... + 33%
24 ... 60 V DC, AC	AC ± 15%

or power supply from voltage measuring input:

24 ... 60 V AC or 85 ... 230 V AC,  
Note:  $40 \text{ Hz} \leq f \leq 400 \text{ Hz}$

Option:

Connect to the low tension to terminals 12 and 13  
24 V AC or 24 ... 60 V DC

Power consumption:

3 VA

### Installation data

Mechanical design:

Housing **P13/70**

Material of housing:

Lexan 940 (polycarbonate)  
flammability Class V-0 acc. to UL 94, self-extinguishing, non-dripping, free of halogen

Mounting:

For rail mounting

Mounting position:

Any

Weight:

Approx. 0.27 kg

### Connecting terminals

Connection element:

Screw-type terminals with indirect wire pressure

Permissible cross section of the connection leads:

$\leq 4.0 \text{ mm}^2$  single wire or  
 $2 \times 2.5 \text{ mm}^2$  fine wire

### Environmental conditions

Operating temperature:  $-10$  to  $+55$  °C

Storage temperature:  $-40$  to  $+70$  °C

Relative humidity:  $\leq 75\%$ , no dew

Altitude: 2000 m max.

Indoor use statement!

### Ambient tests

EN 60 068-2-6: Vibration

Acceleration:  $\pm 2 \text{ g}$

Frequency range: 10 ... 150 ... 10 Hz, rate of frequency sweep: 1 octave/minute

Number of cycles: 10, in each of the three axes

EN 60 068-2-27: Shock

Acceleration:  $3 \times 50 \text{ g}$

3 shocks each in 6 directions

EN 60 068-2-1/-2/-3: Cold, dry heat, damp heat

IEC 1000-4-2/-3/-4/-5/-6

EN 55 011: Electromagnetic compatibility

### Germanischer Lloyd

Type approval certificate: No. 12 261-98 HH

Ambient category: C

Vibration: 0.7 g

# SINEAX F535

## Transducer for measuring frequency difference

### Output characteristic

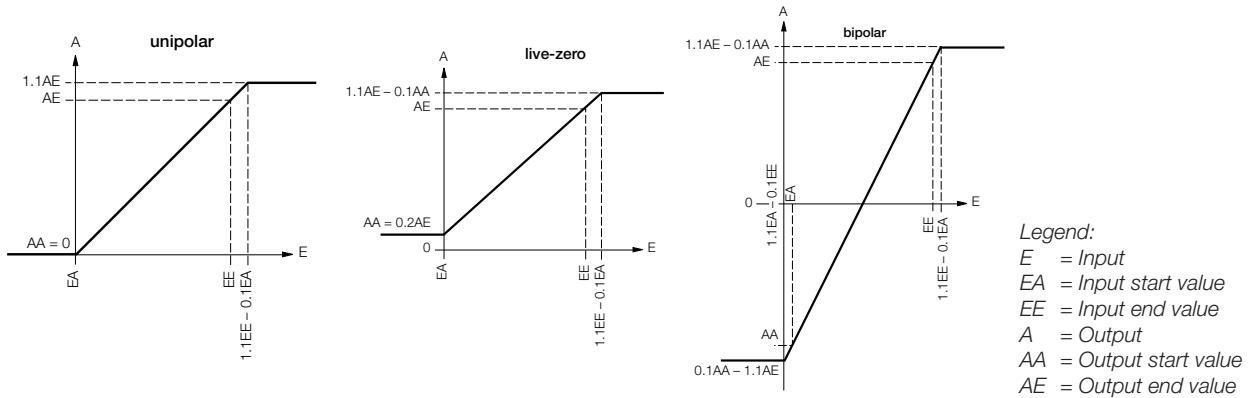

**Table 2: Specification and ordering information**

Description	*Blocking code	no-go with blocking code	Article No./ Feature
<b>SINEAX F535</b>	<b>Order code 535 - xxxx xx</b>		535 -
<b>Features, Selection</b>			
<b>1. Mechanical design</b>			
Housing P13/70 for rail mounting			4
<b>2. Nominal input voltage</b>			
Generator and bus bar: $U_N$ : 10 ... 230 V			1
$U_N$ : > 230 ... 690 V Not possible with power supply from measuring input	A		2
3 phase system: Input voltage = phase to phase voltage			
<b>3. Measuring range</b>			
Frequency: Bus bar = $f_s$ / Generator = $f_G$			
$f_s = 50$ Hz / $f_G = 49.5$ ... 50 ... 50.5 Hz			1
$f_s = 50$ Hz / $f_G = 47.5$ ... 50 ... 52.5 Hz			2
$f_s = 50$ Hz / $f_G = 45$ ... 50 ... 55 Hz			3
$f_s = 50$ Hz / $f_G = 40$ ... 50 ... 60 Hz			4
$f_s = 60$ Hz / $f_G = 57.5$ ... 60 ... 62.5 Hz			5
Non-standard limit values [Hz]			
$\Delta f \pm 1\% f_s$ to $\pm 80\% f_s$ $f_s$ and $f_G \geq 10$ Hz to $\leq 1.5$ kHz With power supply from measuring input min. 40 Hz, max. 400 Hz, see feature 5, lines 3 and 4			9
<b>4. Output signal</b>			
0 ... 20 mA			1
4 ... 20 mA			2
Non-standard 0 ... 1.00 to 0 ... < 20, [mA]			
- 1.00 ... 0 ... 1.00 to - 20 ... 0 ... 20 (symmetrical)			9
1 ... 5 to < (4 ... 20) (AA/AE = 1/5)			
0 ... 10 V			A
Non-standard 0 ... 1.00 to 0 ... < 10, [V]			
- 1.00 ... 0 ... 1.00 to - 10 ... 0 ... 10 (symmetrical)			Z
0.2 ... 1 to 2 ... 10 (AA/AE = 1/5)			
AA = Output start value, AE = Output end value			

# SINEAX F535

## Transducer for measuring frequency difference

Description	*Blocking code	no-go with blocking code	Article No./ Feature
<b>SINEAX F535</b>	<b>Order code 535 - xxxx xx</b>		535 -
<b>Features, Selection</b>			
<b>5. Power supply</b>			
85 ... 230 V DC, AC			1
24 ... 60 V DC, AC			2
Internal from measuring input (24 ... 60 V AC)		A	3
Internal from measuring input (85 ... 230 V AC)		A	4
Connect to the low tension 24 V AC / 24 ... 60 V DC			5
<b>6. Response time</b>			
4 periods of the input frequency (standard)			1
2 periods of the input frequency			2
8 periods of the input frequency			3
16 periods of the input frequency			4

\* Lines with letter(s) under "no-go" cannot be combined with preceding lines having the same letter under "Blocking code".

### Electrical connections

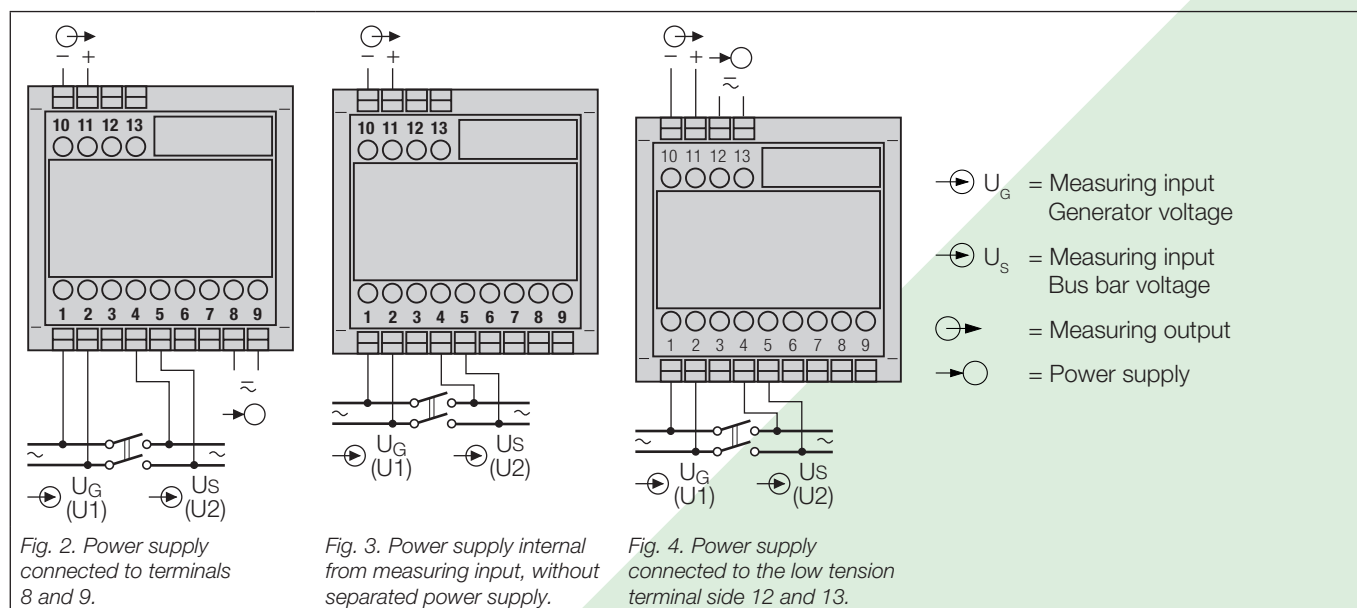

### Dimensional drawing

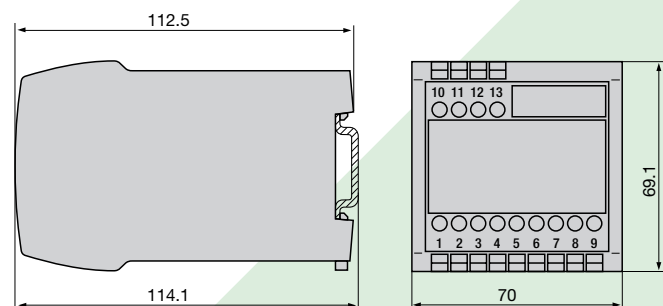

Fig. 5. Housing **P13/70** clipped onto a top-hat rail (35 x 15 mm or 35 x 7.5 mm, acc. to EN 50 022).

### Standard accessories

1 Operating instructions in three languages: German, French, English

**CAMILLE BAUER**

Rely on us.

Camille Bauer Ltd  
 Aargauerstrasse 7  
 CH-5610 Wohlen / Switzerland

Phone: +41 56 618 21 11

Fax: +41 56 618 35 35

e-mail: [info@camillebauer.com](mailto:info@camillebauer.com)

[www.camillebauer.com](http://www.camillebauer.com)