

# DSP7000 Series High-Speed Programmable Dynamometer Controllers

DSP7001 - single channel  
DSP7002 - dual channel

## FEATURES

- **DSP7001 Single Channel:** Low cost and easy to use
- **DSP7002 Dual Channel:** Enables the support of two testing instruments with independent or tandem configurations and two fully independent control loops
- **Built-in Alarm System:** For power, speed, torque, temperature, air flow, water flow, electrical overload and external inputs
- **High Speed Data Acquisition:** Up to 500 torque and speed points per second of both channels with time stamp
- **High Quality, Easy-to-Read Vacuum Fluorescent Readout:** Displays torque, speed, power, auxiliary and PID (proportional gain, integral and derivative) values
- **Fast Full-Curve Data Acquisition:** Free-run to locked rotor in seconds
- **Speed & Torque Operating Modes:** PID settings for exceptional dynamometer control
- **Programmable Digital PID Values:** Controlled and stored via M-Test Software or controlled manually
- **Built-in Current-Regulated Supply:** For use with Hysteresis Dynamometer or brakes up to 1amp
- **Adjustable Torque Units:** English, Metric and SI are standard
- **Digital Filter:** Removes undesired noise from torque signals
- **Saving:** Currently used configuration can be saved and recalled at power up
- **Single or Multi-point Torque and Speed Stabilized Testing:** Via M-TEST 7.0 Software
- Closed Box Calibration
- **Rack Mounting:** 19" (482.6 mm) with handles
- **Backwards Compatible:** Compatible with the DSP6001 (in DSP6001 mode)
- **HD5 dynamometers:** Supported
- **USB:** Standard
- **Low RPM:** calculation from angle (quadrature signal) and time designed to capture RPM's as low as .001 RPM
- **Position Measurement:** Two quadrature decoders

## OPTIONS

- Interfaces: RS-232 and IEEE-488
- I/O card accessible programmatically (LabVIEW™, Visual C)

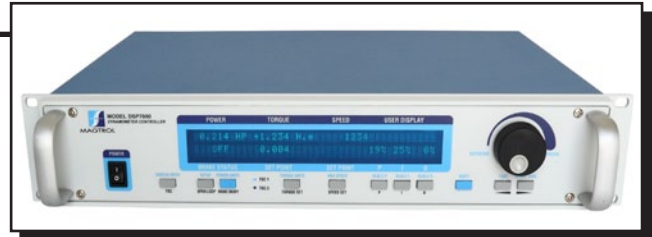

## DESCRIPTION

Magtrol's Model DSP7000 High Speed Programmable Dynamometer Controller employs state-of-the-art Digital Signal Processing Technology to provide superior motor testing capabilities. Designed for use with any Magtrol Hysteresis, Eddy-Current or Powder Dynamometer, Magtrol In-Line Torque Transducer or auxiliary instrumentation, the DSP7000 can provide complete PC control via the USB or optional IEEE-488 or RS-232 interface. With up to 500 readings per second, the DSP7000 is ideally suited for both the test lab and the production line.

## APPLICATIONS

In the laboratory, the DSP7000's high sample rate provides superior resolution for data acquisition and curve plotting. This allows for capturing more usable motor test data during switching, breakdown and other transitional areas of the motor test curve. For production and incoming inspection, the DSP7000 displays torque, speed and power at all times, allowing the Controller to be used as a manual stand alone unit or as part of a complete PC system.

## MOTOR TESTING SOFTWARE

Magtrol's M-TEST 7 Software (*sold separately*) is a state-of-the-art motor testing program for Windows®-based data acquisition. Used with the Magtrol DSP7000 Controller, Magtrol M-TEST 7 Software provides the control of any Magtrol Dynamometer and runs test sequences in a manner best suited to the overall accuracy and efficiency of the Magtrol Motor Test System. The data that is generated by Magtrol's Motor Testing Software can be stored, displayed and printed in tabular or graphic formats, and can be easily imported into a spreadsheet.

Written in LabVIEW™, M-TEST 7 has the flexibility to test a majority of motor types in a variety of ways. Because of LabVIEW's versatility, obtaining data from other sources (e.g. thermocouples), controlling motor power and providing audio/visual indicators is relatively easy.

Magtrol's M-TEST 7 Software is ideal for simulating loads, cycling the unit under test and motor ramping. Because it is easy to gather data and duplicate tests, the software is ideal for use in engineering labs, production testing and incoming/outgoing inspection.

**SPECIFICATIONS**

MEASUREMENT CHARACTERISTICS	
Maximum Torque	99,999 units
Maximum Speed	199,999 rpm
Accuracy	Speed: 0.01% of reading from 5 rpm to 200,000 rpm Torque: $\pm 0.05\%$ of range ( $\pm 2$ mV)
ELECTRICAL CHARACTERISTICS	
Voltage Requirements	85-264 VAC 50/60 Hz
Power Requirements	210 VA
Fuses (5 x 20 mm)	Brake: IEC 1.25 A 250 V T Main Power: IEC 2.5 A 250 V T
Max. Compliance Voltage	48 VDC, Brake Output
Max. Brake Output Current	1 Amp, Calibrated that 100% OL = 1 Amp
TSC1 and TSC2 User Power Supplies	24 Volt DC 450 mA (power supply fault protected) 5 Volt DC 200 mA (internal fuse at 500 mA)
ENVIRONMENT	
Operating Temperature	5 °C to 40 °C
Relative Humidity	< 80%
Temperature Coefficient	0.004% of range/°C of 5 VDC for both channels

DIMENSIONS		
Width	19.0 in	483 mm
Height	3.5 in	89 mm
Depth	12.4 in	315 mm
with handles	13.8 in	351 mm
Weight	15.2 lb	6.9 kg

Optional equipment may be factory installed or purchased separately and user installed.

**OPTIONAL EQUIPMENT**
**COMMUNICATIONS**
**RS-232 Interface**

The RS-232 Interface provides backwards compatibility for older systems. 300, 600, 1200, 2400, 4800, 9600, 19200 and 115200 Baud rates are supported.

**GPIB IEEE-488 Interface**

The GPIB IEEE-488 Interface provides standard GPIB communications.

**I/O CARD**

- Torque/Speed Analog Outputs: For interface with a data acquisition system
- Analog Signal such as tachometer can be routed to PID loop
- External alarm input
- Alarm relay contacts
- 2 Relays
- 3 Digital inputs
- 2 Digital outputs
- 2 Analog inputs
- 2 Analog outputs
- 5 Volts available to user fused at 500 mA. Nominal 200 mA
- All I/O data can be accessed by LabVIEW™

**FRONT PANEL**

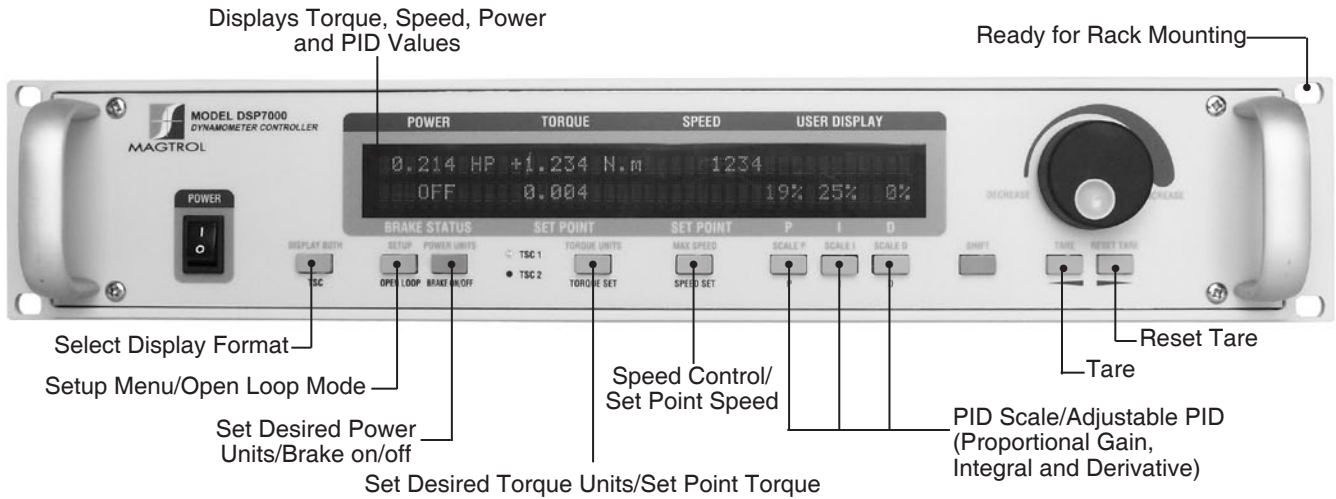

**REAR PANELS**

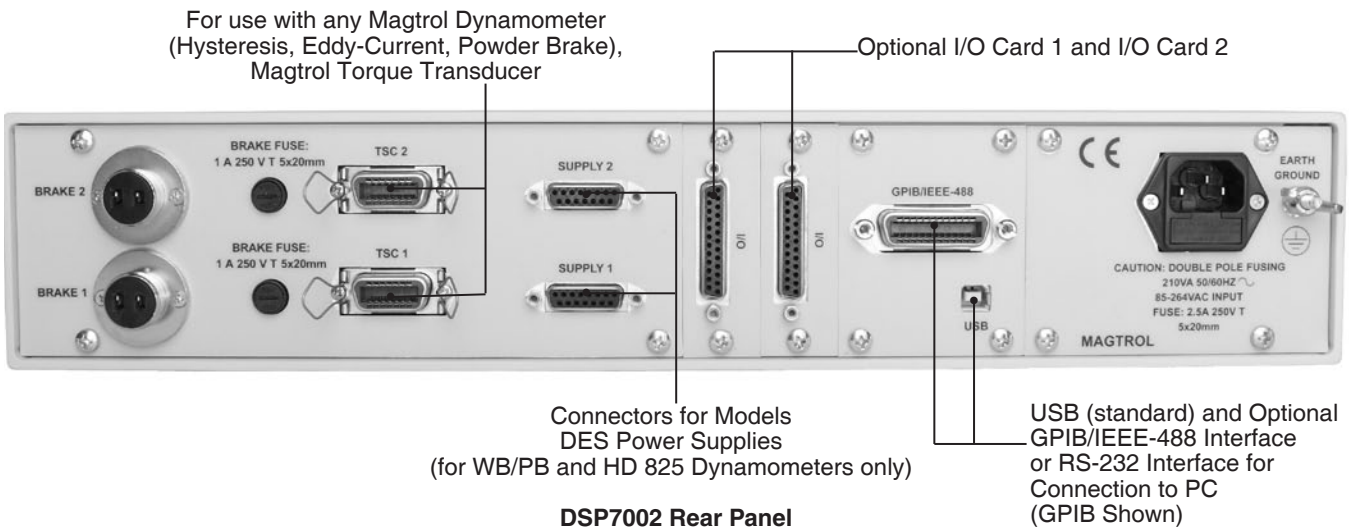
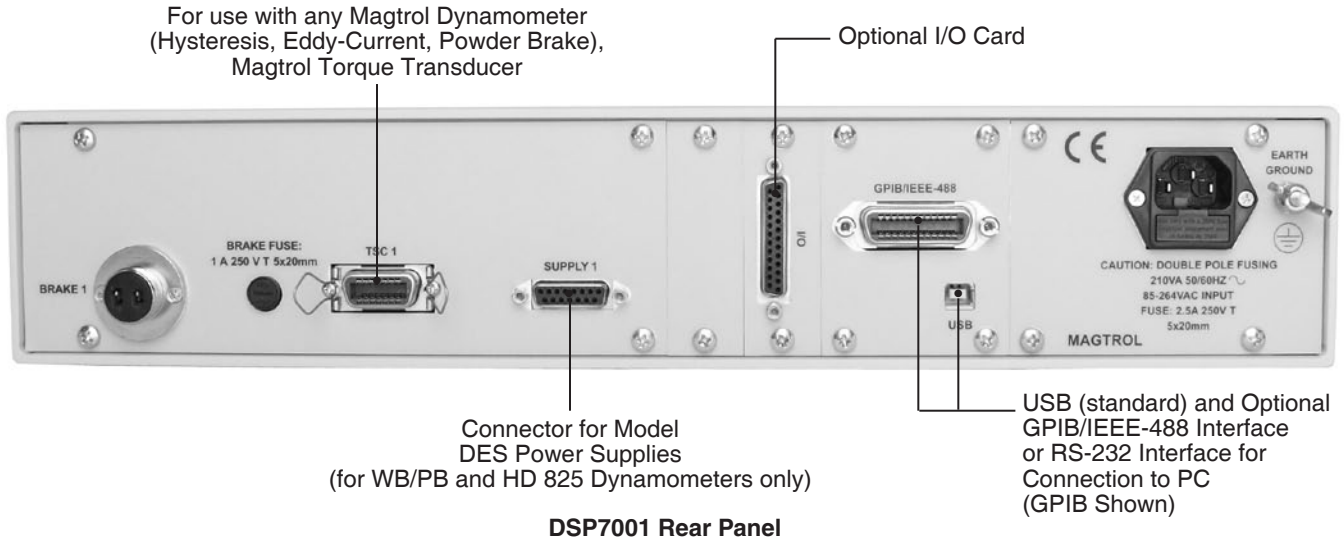

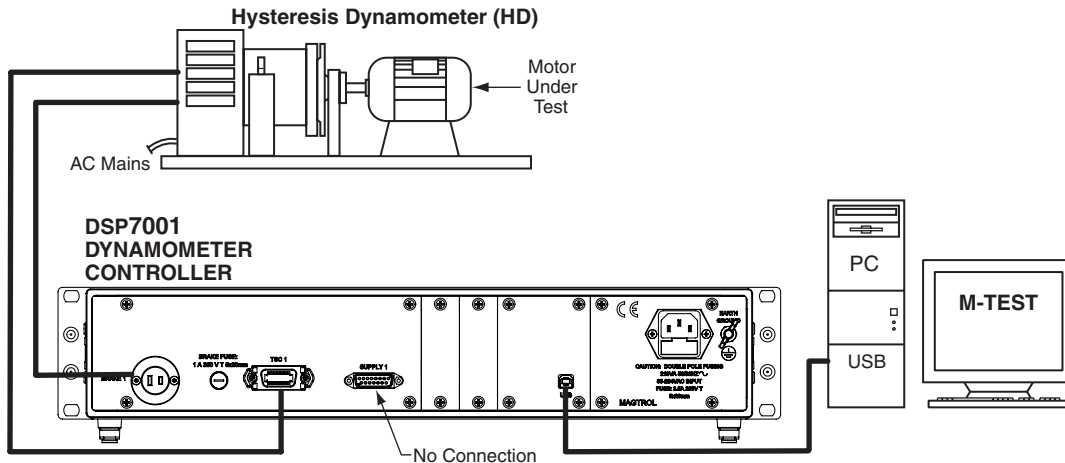

DSP7001 Connected to Hysteresis Dynamometer

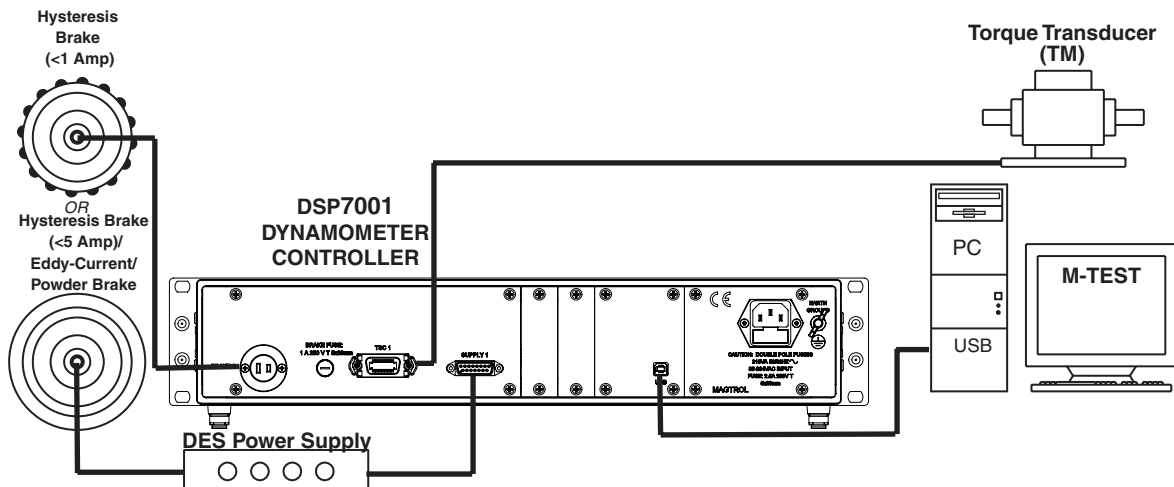

DSP7001 Connected to a Hysteresis or Eddy-Current/Powder Brake with In-Line Torque Transducer

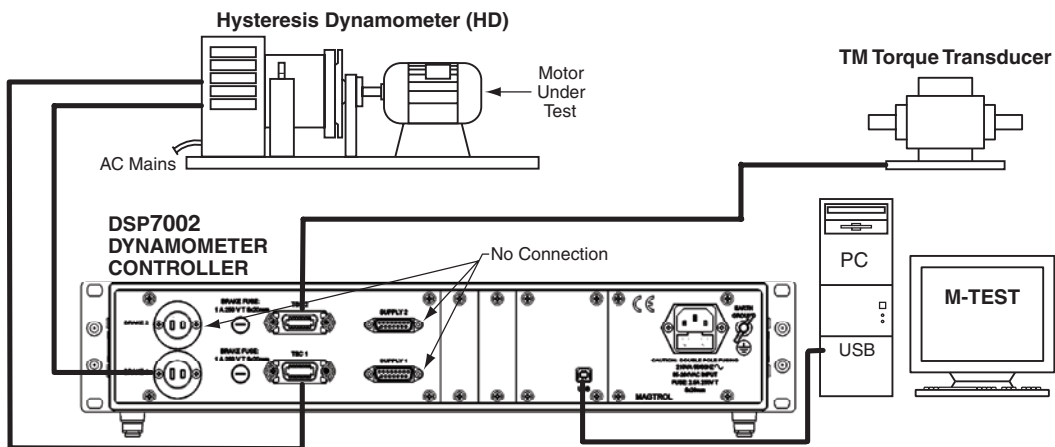

DSP7002 Connected to Hysteresis Dynamometer with In-Line Torque Transducer

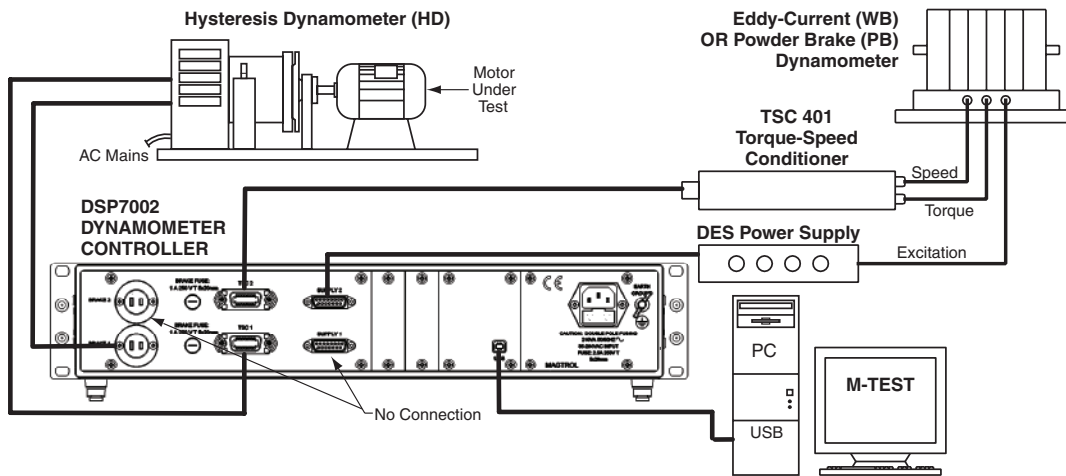

DSP7002 Connected to Hysteresis Dynamometer and Eddy-Current or Powder Brake Dynamometer

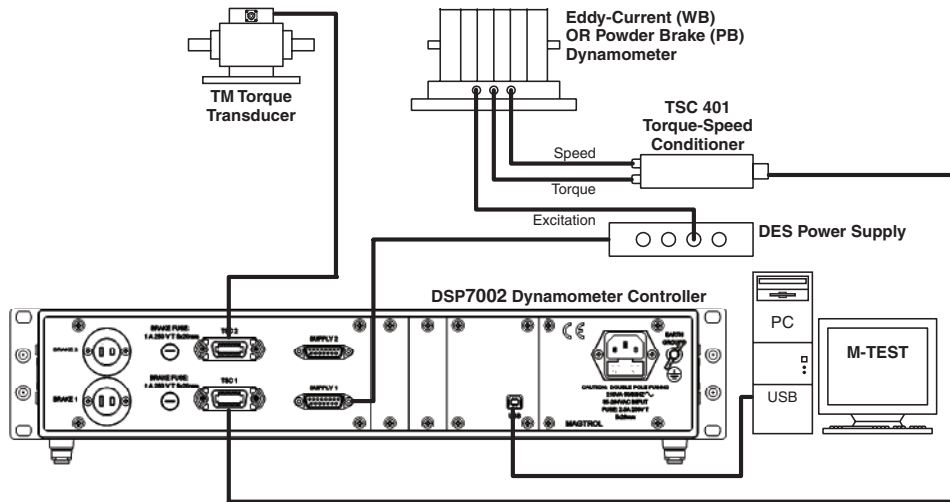

DSP7002 Connected to Eddy-Current or Powder Brake Dynamometer (WB/PB) with In-Line Torque Transducer

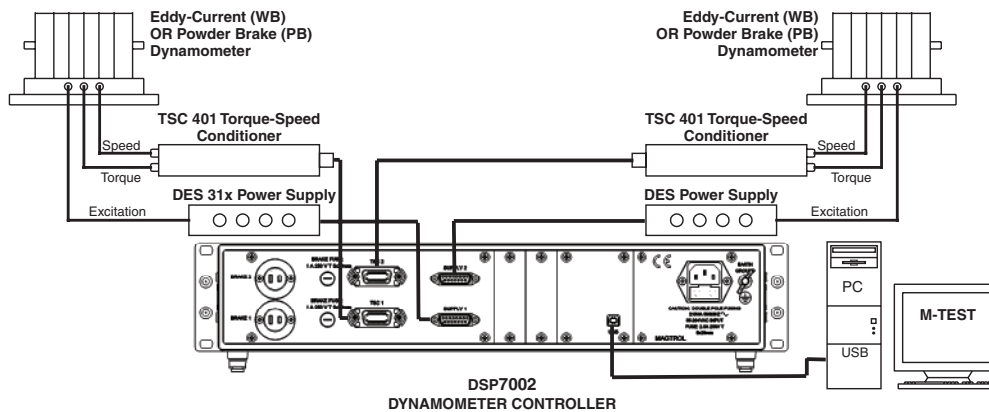

DSP7002 Connected to 2 Eddy-Current or Powder Brake Dynamometers (Independent Setup)

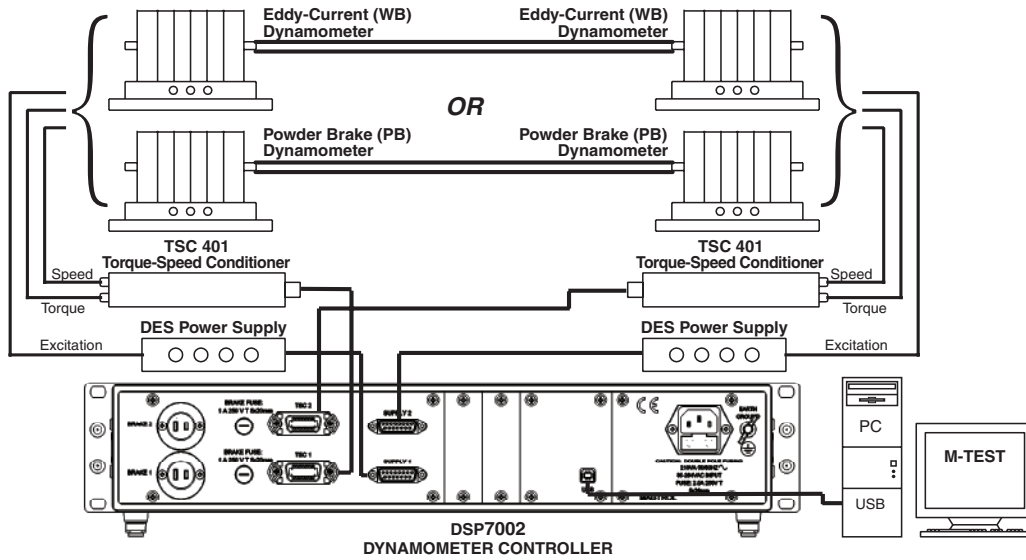

**DSP7002 Connected to 2 Eddy-Current or 2 Powder Brake Dynamometers (Tandem Setup)**

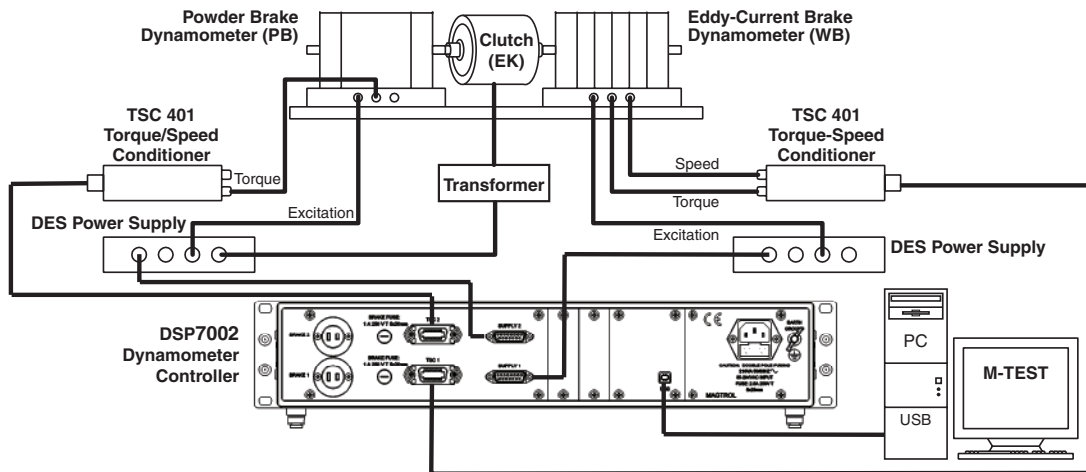

**DSP7002 Connected to Eddy-Current and Powder Brake Dynamometer (Tandem Setup)**



## CUSTOM MOTOR TEST SYSTEM

The DSP can be incorporated into a Customized Motor Test System. These PC based, turn-key systems are custom designed and built to meet specific user requirements.

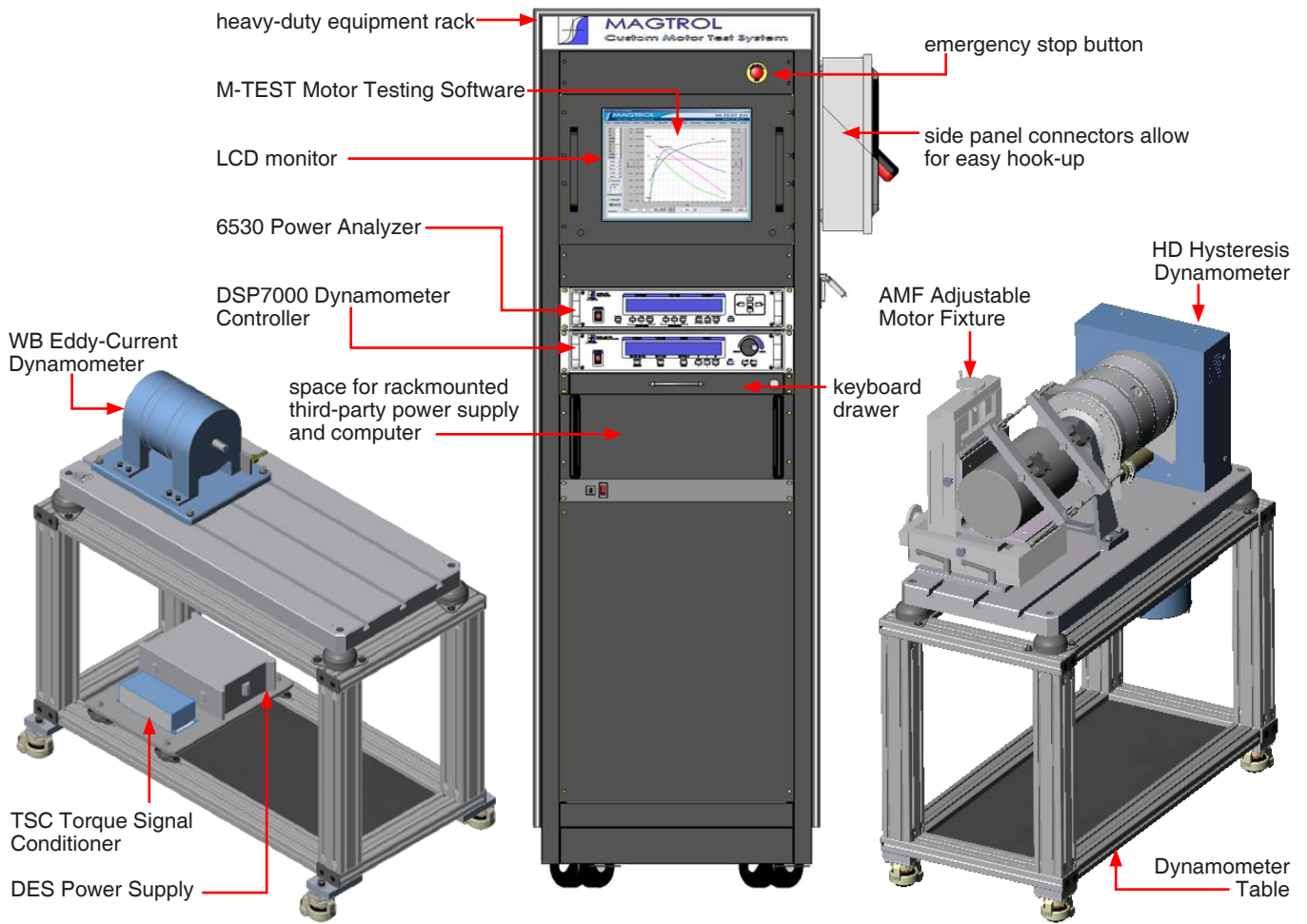

**ORDERING INFORMATION**

- DSP7001** High-Speed Programmable Dynamometer Controller - single channel  
**DSP7002** High-Speed Programmable Dynamometer Controller - dual channel

Model Number:	DSP700X - X - X
CHANNEL TYPE	
• Single Channel _____	1
• Dual Channel _____	2
COMMUNICATION OPTIONS	
• none (standard USB) _____	0
• USB port and GPIB _____	1
• USB port and RS-232 _____	2
I/O Options	
• None (standard) _____	0
• I/O card in slot1 (7001) _____	1
• I/O card in slot 1 and 2 (7002) _____	3

**SYSTEM OPTIONS AND ACCESSORIES**

CATEGORY	DESCRIPTION	MODEL / PART #
TESTING DEVICES	Hysteresis Dynamometers	HD series
	Eddy-Current Dynamometers	WB series
	Powder Brake Dynamometers	PB series
	In-Line Torque Transducers	TM/TMHS/TMB series
POWER ANALYZERS	High-Speed Single-Phase Power Analyzer	6510 <sub>e</sub>
	High-Speed Three-Phase Power Analyzer	6530
SOFTWARE	M-TEST 7.0 Motor Testing Software	SW-M-TEST7.0-WE
	Temperature Testing Hardware	HW-TTEST
POWER SUPPLIES	Closed-Loop Speed Control/Power Supply	6100
	Power Supply	5200
	Current-Regulated Power Supply	5210
	Power Amplifier (required for HD-825 Dynamometer only)	5241
	Power Supply for WB & PB Dynamometers series 2.7 and 43	DES 310/410
	Power Supply for WB & PB Dynamometer series 65, 115 and 15	DES 311/411
MISC.	Torque/Speed Conditioner (required for connecting WB/PB Series Dynamometers to DSP6001)	TSC 401
CARDS & CABLES	GPIB Interface Card (PCI)	73M023
	GPIB Cable, 1 meter	88M047
	GPIB Cable, 2 meters	88M048
	Torque Transducer Connector Cable	ER 113/01
	DSP7000 GPIB Card	006579
	DSP7000 RS-232 Card	006578
	DSP7000 I/O Card	006577

*Due to the continual development of our products, we reserve the right to modify specifications without forewarning.*

[www.magtrol.com](http://www.magtrol.com)
**MAGTROL INC**

70 Gardenville Parkway  
 Buffalo, New York 14224 USA  
 Phone: +1 716 668 5555  
 Fax: +1 716 668 8705  
 E-mail: magtrol@magtrol.com

**MAGTROL SA**

Route de Montena 77  
 1728 Rossens/Fribourg, Switzerland  
 Phone: +41 (0)26 407 3000  
 Fax: +41 (0)26 407 3001  
 E-mail: magtrol@magtrol.ch

**Subsidiaries in:**

Germany • France  
 China • India

Worldwide Network  
 of Sales Agents

