

Absolute encoders - singleturn

Compact magnetic

Sendix M3658 / M3678 (shaft / hollow shaft)

CANopen

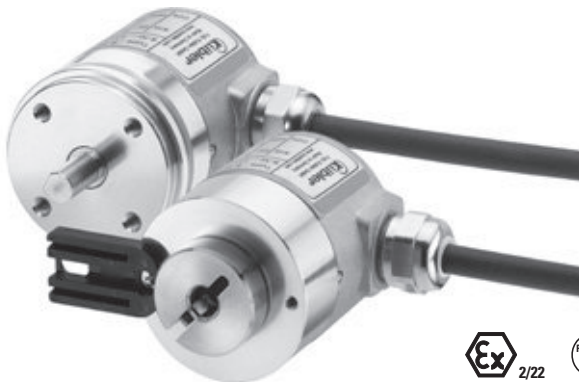

The Sendix M3658 and Sendix M3678 absolute encoders - singleturn with CANopen interface and magnetic sensor technology boast a resolution of 14 bits.

With a protection rating of up to IP69k, these encoders are resistant to shock and to extreme fluctuations in temperature, making them ideal for use in the most demanding outdoor applications.



Safety-Lock™



High rotational speed



Temperature range
-40°...+85°C



High protection level



High shaft load capacity



Shock / vibration resistant



Short-circuit proof



Reverse polarity protection



Magnetic sensor



Surface protection salt spray-tested optional

Safe technology

- Increased resistance against vibration and installation errors.
- Sturdy bearing construction in Safety-Lock™ design.
- Resistant die-cast-housing and protection up to IP69k.

Versatile applications

- CANopen encoder profile DS406 V3.2.
- Fast determination of the operating status via two-colour LED.
- With M12 connector or cable connection.

Safety-Lockplus™

IP69k protection on the flange side, robust bearing assemblies with interlocking bearings, mechanically protected shaft seal.

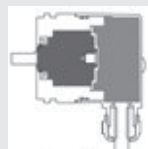

Sensor-Protect™

Fully encapsulated electronics, separate mechanical bearing assembly.

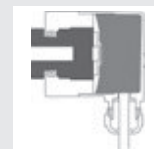

Order code shaft version

8.M3658 . **2XCX** . **21 1X**
Type a b c d e f

If for each parameter of an encoder the underlined preferred option is selected, then the delivery time will be 10 working days for a maximum of 10 pieces. Qts. up to 50 pcs. of these types generally have a delivery time of 15 working days.



a Flange

2 = synchro flange, ø 36 mm [1.42"]

b Shaft (ø x L), with flat

3 = ø 6 x 12.5 mm [0.24 x 0.49"]
6 = ø 8 x 12.5 mm [0.32 x 0.49"]
5 = ø 1/4" x 12.5 mm [0.49"]

c Interface / power supply

C = CANopen DS301 V4.02 / 8 ... 30 V DC

d Type of connection

2 = radial cable, 1 m [3.28] PUR
B = radial cable, special length PUR *)
4 = radial M12 connector, 5-pin

*) Available special lengths (connection types B):
2, 3, 5, 8, 10, 15 m [6.56, 9.84, 16.40, 26.25, 32.80, 49.21']
order code expansion .XXXX = length in dm
ex.: 8.M3658.23CB.2111.0030 (for cable length 3 m)

e Fieldbus profile

21 = CANopen encoder profil DS406 V3.2

f Protection

1 = IP67
2 = IP69k

Optional on request

- Ex 2/22 (only for type of connection 4)
- surface protection salt spray tested

Absolute encoders - singleturn

Compact magnetic	Sendix M3658 / M3678 (shaft / hollow shaft)	CANopen
-------------------------	--	----------------

Order code hollow shaft	8.M3678 Type	.XXCX a b c d	.211X e f	<p>If for each parameter of an encoder the <u>underlined preferred option</u> is selected, then the delivery time will be 10 working days for a maximum of 10 pieces. Qts. up to 50 pcs. of these types generally have a delivery time of 15 working days.</p>
a Flange	d Type of connection	e Fieldbus profile	f Protection	
2 = with spring element, long <u>5 = with stator coupling, ø 46 mm [1.81"]</u>	2 = radial cable, 1 m [3.28] PUR B = radial cable, special length PUR *) <u>4 = radial M12 connector, 5-pin</u>	<u>21 = CANopen encoder profil DS406 V3.2</u>	<u>1 = IP67</u> 2 = IP69k	
b Hollow shaft <u>2 = ø 6 mm [0.24"]</u> <u>4 = ø 8 mm [0.32"]</u> 6 = ø 10 mm [0.39"] 3 = ø 1/4"	*) Available special lengths (connection type B): 2, 3, 5, 8, 10, 15 m [6.56, 9.84, 16.40, 26.25, 32.80, 49.21"] order code expansion .XXXX = length in dm ex.: 8.M3678.52CB.2111.0030 (for cable length 3 m)	<i>Optional on request</i> - Ex 2/22 (only for type of connection 4) - surface protection salt spray tested		
c Interface / power supply <u>C = CANopen DS301 V4.02 / 8 ... 30 V DC</u>				

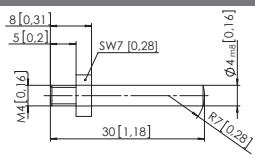
Mounting accessory for shaft encoders	Order no.
Coupling bellows coupling ø 19 mm [0.75"] for shaft 6 mm [0.24"]	8.0000.1102.0606
Mounting accessory for hollow shaft encoders	Order no.
Cylindrical pin, long for torque stops 	8.0010.4700.0000
Connection technology	Order no.
Connector, self-assembly (straight) M12 female connector with coupling nut	8.0000.5116.0000
Cordset, pre-assembled M12 female connector with coupling nut, 6 m [19.69'] PVC cable	05.00.6091.A211.006M

Further accessories can be found in the accessories section or in the accessories area of our website at: www.kuebler.com/accessories.
 Additional connectors can be found in the connection technology section or in the connection technology area of our website at: www.kuebler.com/connection_technology.

Technical data

Mechanical characteristics		Electrical characteristics	
Maximum speed	6000 min ⁻¹	Power supply	8 ... 30 V DC
Starting torque at 20°C [68°F]	< 0.06 Nm	Current consumption (no load)	max. 25 mA
Shaft load capacity	radial 40 N axial 20 N	Reverse polarity protection of the power supply	yes
Weight	approx. 0.2 kg [7.06 oz]	Measuring range	360°
Protection acc. to EN 60529/DIN 40050-9	IP67 / IP69k	Absolute accuracy, 25°C [77°F]	±1°
Working temperature range	-40°C ... +85°C [-40°F ... +185°F]	Repeat accuracy, 25°C [77°F]	±0.2°
Materials	shaft / hollow shaft stainless steel flange aluminium housing zinc die-cast cable PUR	Data refresh rate	400 µs
Shock resistance acc. to EN 60068-2-27	5000 m/s ² , 6 ms	CE compliant acc. to	EMC guideline 2004/108/EC RoHS guideline 2011/65/EU
Vibration resistance acc. to EN 60068-2-6	300 m/s ² , 10 ... 2000 Hz	Diagnostic LED (two-colour, red/green)	
Permanent shock resistance acc. to EN 60068-2-27	1000 m/s ² , 2 ms	LED ON or blinking	red error display green status display
Vibration (broad-band random) acc. to EN 60068-2-64	5 ... 2500 Hz, 100 m/s ² - rms		

Absolute encoders singleturn

Absolute encoders - singleturn

Compact magnetic	Sendix M3658 / M3678 (shaft / hollow shaft)	CANopen
-------------------------	--	----------------

Interface characteristics CANopen	
Resolution	1 ... 16384 (14 bit), scalable default: 16384 (14 bit)
Code	binary
Interface	CAN high-speed acc. to ISO 11898, Basic- and Full-CAN, CAN specification 2.0 B
Protocol	CANopen profile DS406 V3.2 with manufacturer-specific add-ons, LSS-Service DS305 V2.0

Baud rate	10 ... 1000 kbit/s software configurable
Node address	1 ... 127 software configurable
Termination	software configurable
LSS protocol	CIA LSS protocol DS305, global command support for node address and baud rate, selective commands via attributes of the identity object

General information about CANopen

The CANopen encoders support the latest CANopen communication profile according to DS301 V4.2.

In addition, device specific profiles like the encoder profile DS406 V3.2 are available.

The following operating modes may be selected: Polled Mode, Cyclic Mode, Sync Mode. Moreover, scale factors, preset values, limit switch values and many other additional parameters can be programmed via the CANbus.

When switching the device on, all parameters are loaded from an EEPROM, where they were saved previously to protect them against power-failure.

The following output values may be combined in a freely variable way as PDO (PDO mapping): **position, speed** as well as the **status of the working area**.

The encoders are available with a connector or a cable connection.

The device address and baud rate can be set/modified by means of the software.

The two colour LED located on the back indicates the operating or fault status of the CANbus, as well as the status of the internal diagnostics.

CANopen communication profile DS301 V4.02

Among others, the following functionality is integrated.

Class C2 functionality:

- NMT slave.
- Heartbeat protocol.
- Identity object.
- Error behaviour object.
- Variable PDO mapping self-start programmable (power on to operational), 3 sending PDO's.
- Node address, baud rate and CAN bus / programmable termination.

CANopen encoder profile DS406 V3.2

The following parameters can be programmed:

- Event mode.
- 1 work area with upper and lower limit and the corresponding output states.
- Variable PDO mapping for position, speed, work area status.
- Extended failure management for position sensing.
- User interface with visual display of bus and failure status 1 LED two colours.
- Customer-specific memory - 16 Bytes.
- Customer-specific protocol.
- "Watchdog controlled" device.

LSS protocol profile DS305 V2.0

- Global command support for node ID and baud rate configuration.
- Selective protocol via identity object (1018h).

CANbus connection

The CANopen encoders are equipped with a bus trunk line in various lengths and can be terminated in the device.

The devices do not have an integrated T-coupler nor they are looped internally and must therefore only be used as end devices.

If possible, drop lines should be avoided, as in principle they lead to signal reflections. As a rule the reflections caused by the drop lines are not critical, if they have completely decayed before the point in time when the scanning occurs.

The sum of all the drop lines should not, for a particular baud rate, exceed the maximum length L_u .

$L_u < 5 \text{ m [16.40']}$ cable length for 125 Kbit.

$L_u < 2 \text{ m [6.56']}$ cable length for 250 Kbit.

$L_u < 1 \text{ m [3.28']}$ cable length for 1 Mbit.

When used as a drop line, the termination resistor should not be activated.

For a network with 3 encoders and 250 Kbit the maximum length of the drop line/encoder must not exceed 70 cm.

Terminal assignment

Interface	Type of connection	Cable (isolate unused wires individually before initial start-up)					
C	2, B	Signal:	+V	0 V	CAN_GND	CAN_H	CAN_L
		Cable colour:	BN	WH	GY	GN	YE
Interface	Type of connection	M12 connector, 5-pin					
C	4	Signal:	+V	0 V	CAN_GND	CAN_H	CAN_L
		Pin:	2	3	1	4	5

Top view of mating side, male contact base



M12 connector, 5-pin

Absolute encoders - singleturn

Compact magnetic **Sendix M3658 / M3678 (shaft / hollow shaft)** **CANopen**

Dimensions shaft version

Dimensions in mm [inch]

Synchro flange, \varnothing 36 [1.42]

Flange type 2

(drawing with cable)

- 1 4 x M3, 6 [0.24] deep

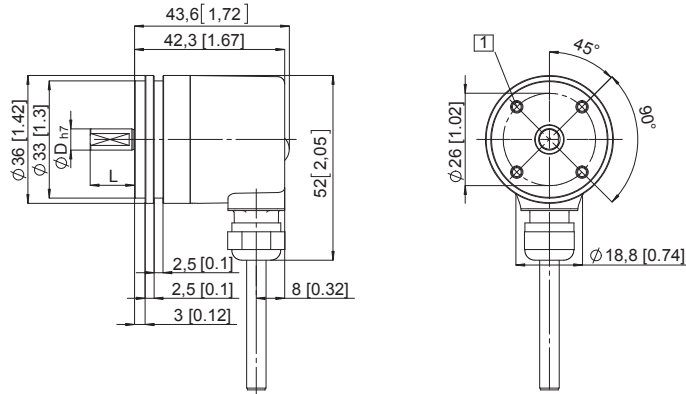

Synchro flange, \varnothing 36 [1.42]

Flange type 2

(drawing with M12 connector)

- 1 4 x M3, 6 [0.24] deep

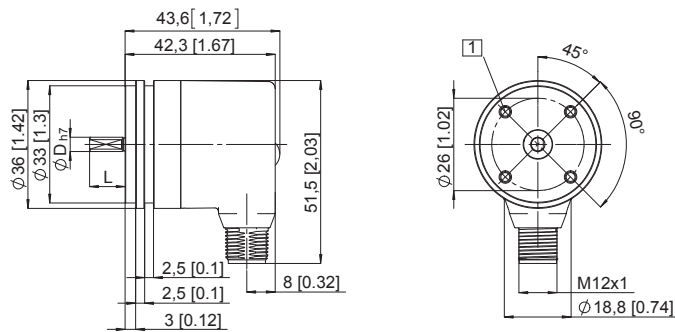

D	L	Fit
6 [0.24]	12.5 [0.49]	h7
8 [0.32]	12.5 [0.49]	h7
1/4"	12.5 [0.49]	h7

Dimensions hollow shaft version

Dimensions in mm [inch]

Flange with spring element, long

Flange type 2

- 1 Torque stop slot, recommendation: cylindrical pin DIN 7, \varnothing 4 [0.16]
- 2 Recommended torque for the clamping ring 0.7 Nm

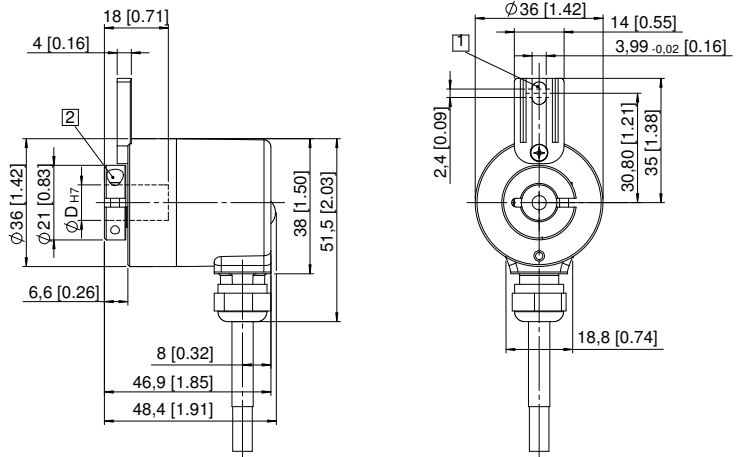

Flange with stator coupling, \varnothing 46 [1.81]

Flange type 5

- 1 Recommended torque for the clamping ring 0.7 Nm

