

Technical Data Sheet TI-F50 Locking Units series KFH

For a detailed functional description refer to "Technical Information TI-F10".
 Further important practical advice is given in "Operating Manual BA-F50".

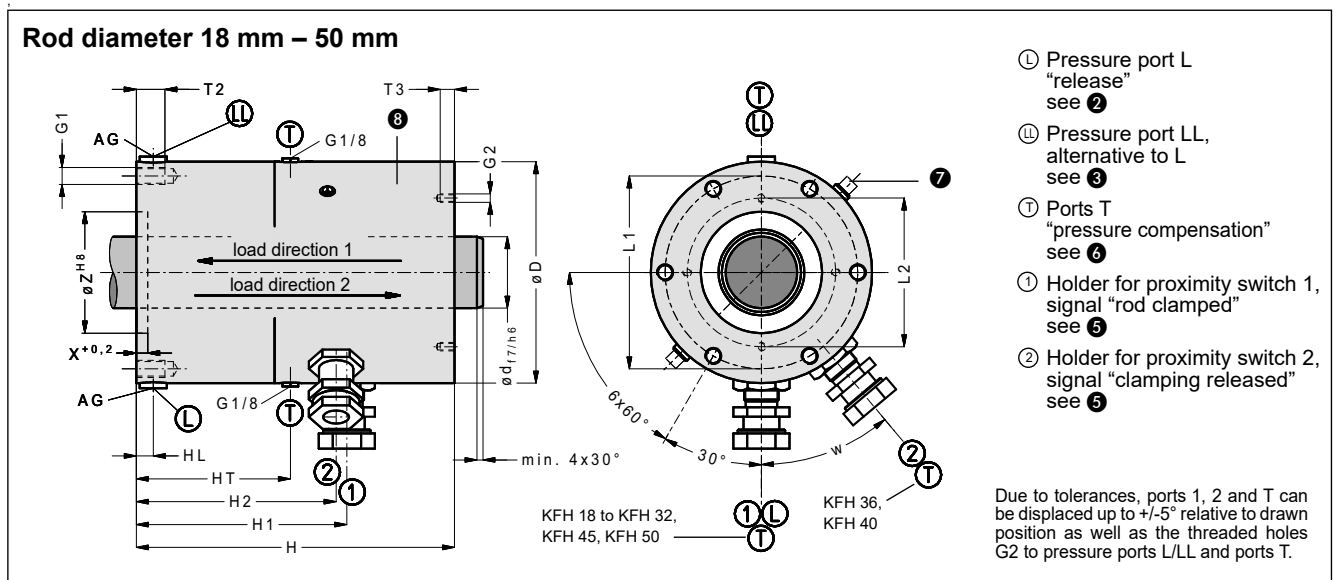

Fig. 1: Dimensions Locking Unit KFH (CAD-files download at www.sitema.com)

Type	ID no. (order no.)	d mm	F kN	p bar	D mm	H mm	L1 mm	L2 mm	T2 mm	T3 mm	G1	G2	Z mm	X mm	AG	V cm ³	HL mm	H1 mm	H2 mm	HT mm	w mm	Wgt kg
KFH 18	KFH 018 70	18	10	70	71	137	60	34	12	8	6 x M6	4 x M4	30	4	G1/8	6	29	105	98	68	45°	4
	KFH 018 71		5	40																		
KFH 25	KFH 025 70	25	20	100	95	140	82	44	15	10	6 x M8	4 x M6	50	6	G1/8	11	19	89.5	83	62	35°	6
	KFH 025 71		12	50																		
KFH 28	KFH 028 70	28	34	100	115	178	96	63	18	10	6 x M10	4 x M6	60	6	G1/4	18	20	118	112	94	30°	12
	KFH 028 71		20	50																		
KFH 32	KFH 032 70	32	34	100	115	178	96	63	18	10	6 x M10	4 x M6	60	6	G1/4	18	20	118	112	94	30°	12
	KFH 032 71		20	50																		

Subject to modification without prior notice

- 1 The nominal holding force F is the minimum holding force for dry or hydraulic-oil wetted rods.
 - 2 The pressure p is required to release the clamping. The admissible operating pressure is 160 bar.
 - 3 As supplied, pressure port LL is plugged by a plug screw. It may be used alternatively to pressure port L and is useful for filling / air-bleeding. We recommend connecting auto-bleeders to the ports which are not in use (not supplied in scope of delivery; available as option - see "Technical Information TI-Z10").
 - 4 Hydraulic operating volume
 - 5 Proximity switch holders are provided for standard inductive proximity switches (M12 x 1 nominal switching distance 2 mm, flush mountable, NO (normally open), except KFH 18 and KFH 25: M8 x 1 with a nominal switching distance of 1.5 mm).
- For easier service, the proximity switch holders have a depth stop and are pre-adjusted when delivered from the factory.
 The switches only need to be inserted to the stop and then clamped.

- The proximity switches are not supplied in the standard scope of delivery, but are available as accessories.
- 6 Internal volume changes during switching are compensated at ports T. An air filter is fitted to one of the ports T for "breathing". The other port T is closed by a plug screw. In a dry and clean factory environment, this offers sufficient protection against dust etc. If, however, moisture or aggressive media are present, a pressure-less hose instead of the filter must be installed to connect the Locking Unit KFH with clean atmosphere (e.g. a clean pressureless container). The other port T must be sealed with a plug screw.
- 7 Lock plates keep the Locking Unit released and need to be removed after installation.
- 8 The surface of the housing parts is ZnNi coated.

Technical Data Sheet TI-F50 Locking Units series KFH

For a detailed functional description refer to “*Technical Information TI-F10*”.
Further important practical advice is given in “*Operating Manual BA-F50*”.

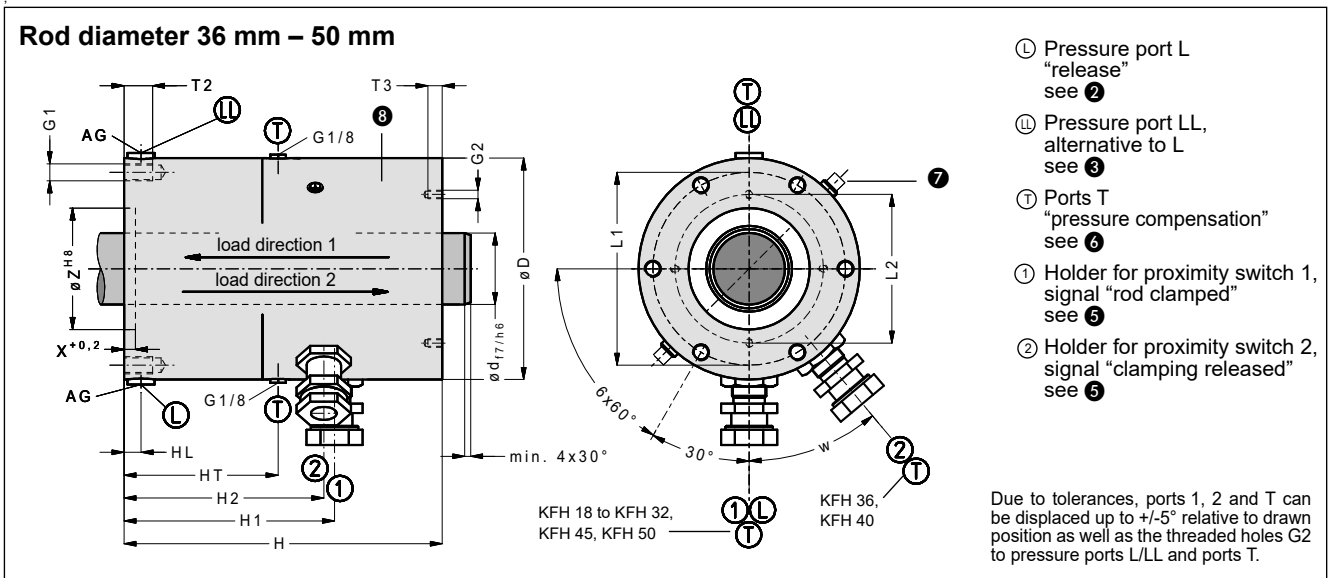

Fig. 2: Dimensions Locking Unit KFH (CAD-files download at www.sitema.com)

Type	ID no. (order no.)	d mm	F kN	p bar	D mm	H mm	L1 mm	L2 mm	T2 mm	T3 mm	G1	G2	Z mm	X mm	AG	V cm ³	HL mm	H1 mm	H2 mm	HT mm	w mm	Wgt kg
KFH 36	KFH 036 70	36	50	100	138	200	115	80	18	14	6 x M10	4 x M6	70	6	G1/4	28	19	109.5	119	96	30°	19
	KFH 036 71		35	55																		
KFH 40	KFH 040 70	40	50	100	155	223	135	96	20	14	6 x M12	4 x M6	85	8	G1/4	39	20	147.5	140	108	30°	26
	KFH 040 71		35	55																		
KFH 45	KFH 045 70	45	75	100	155	223	135	96	20	14	6 x M12	4 x M6	85	8	G1/4	39	20	147.5	140	108	30°	26
	KFH 045 71		45	75																		
KFH 50	KFH 050 70	50	75	100	155	223	135	96	20	14	6 x M12	4 x M6	85	8	G1/4	39	20	147.5	140	108	30°	26
	KFH 050 71		45	75																		

Subject to modification without prior notice

① The nominal holding force F is the minimum holding force for dry or hydraulic-oil wetted rods.

② The pressure p is required to release the clamping. The admissible operating pressure is 160 bar.

③ As supplied, pressure port LL is plugged by a plug screw. It may be used alternatively to pressure port L and is useful for filling / air-bleeding. We recommend connecting auto-bleeders to the ports which are not in use (not supplied in scope of delivery; available as option - see “*Technical Information TI-Z10*”).

④ Hydraulic operating volume

⑤ Proximity switch holders are provided for standard inductive proximity switches (M12 x 1 nominal switching distance 2 mm, flush mountable, NO (normally open)).

For easier service, the proximity switch holders have a depth stop and are pre-adjusted when delivered from the factory. The switches only need to be inserted to the stop and then clamped.

The proximity switches are not supplied in the standard scope of delivery, but are available as accessories.

⑥ Internal volume changes during switching are compensated at ports T. An air filter is fitted to one of the ports for “breathing”. The other port is closed by a plug screw. In a dry and clean factory environment, this offers sufficient protection against dust etc.

If, however, moisture or aggressive media are present, a pressureless hose instead of the filter must be installed to connect the Locking Unit KFH with clean atmosphere (e.g. a clean pressureless container). The other port T must be sealed with a plug screw.

⑦ Lock plates keep the Locking Unit released and need to be removed after installation.

⑧ The surface of the housing parts is ZnNi coated.

Technical Data Sheet TI-F50 Locking Units series KFH

For a detailed functional description refer to "Technical Information TI-F10".
Further important practical advice is given in "Operating Manual BA-F50".

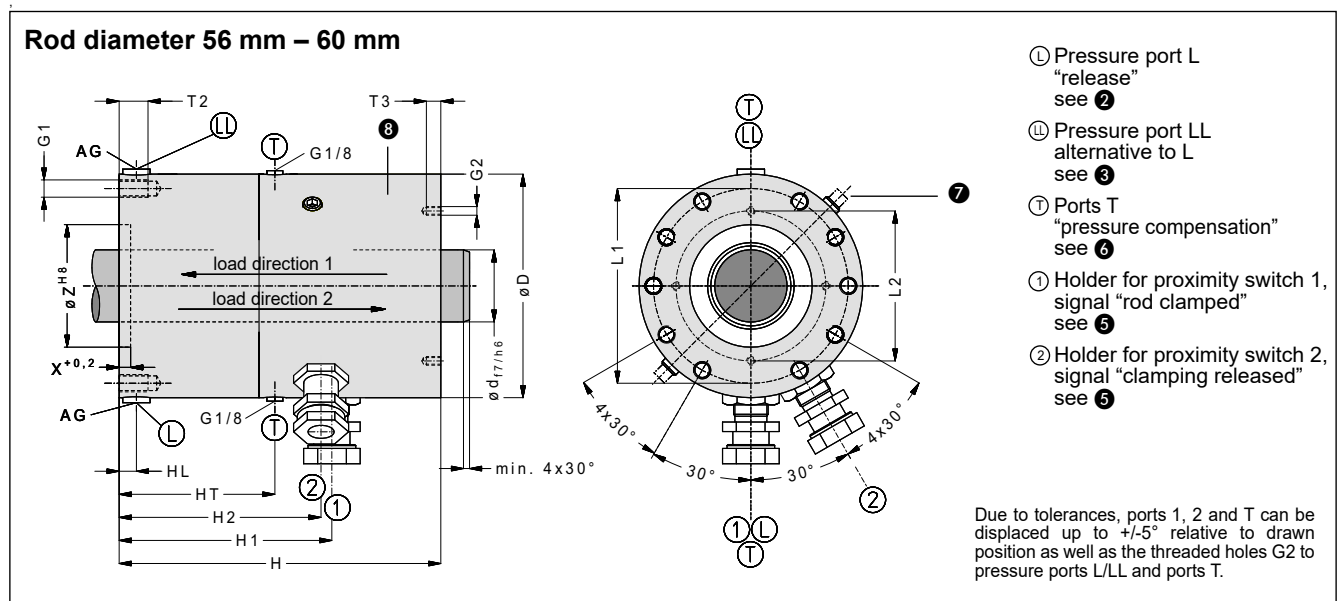

Fig. 3: Dimensions Locking Unit KFH (CAD-files download at www.sitema.com)

Type	ID no.	d	F	p	D	H	L1	L2	T2	T3	G1	G2	Z	X	AG	V	HL	H1	H2	HT	Wgt
	(order no.)	mm	kN	bar	mm	mm	mm	mm	mm	mm			mm	mm		cm ³	mm	mm	mm	mm	kg
KFH 56	KFH 056 70	56	100	100	180	252	160	172	20	13	10 x M12	4 x M6	95	10	G1/4	47	22	151.5	144	105	40
	KFH 056 71		70	70																	
KFH 60	KFH 060 70	60	100	100	180	252	160	172	20	13	10 x M12	4 x M6	95	10	G1/4	47	22	151.5	144	105	40
	KFH 060 71		70	70																	

Subject to modification without prior notice

① The nominal holding force F is the minimum holding force for dry or hydraulic-oil wetted rods.

② The pressure p is required to release the clamping. The admissible operating pressure is 160 bar.

③ As supplied, pressure port LL is plugged by a plug screw. It may be used alternatively to pressure port L and is useful for filling / air-bleeding. We recommend connecting auto-bleeders to the ports which are not in use (not supplied in scope of delivery; available as option - see "Technical Information TI-Z10").

④ Hydraulic operating volume

⑤ Proximity switch holders are provided for standard inductive proximity switches (M12 x 1 nominal switching distance 2 mm, flush mountable, NO (normally open)).

For easier service, the proximity switch holders have a depth stop and are pre-adjusted when delivered from the factory. The switches only need to be inserted to the stop and then clamped.

The proximity switches are not supplied in the standard scope of delivery, but are available as accessories.

⑥ Internal volume changes during switching are compensated at ports T. An air filter is fitted to one of the ports T for "breathing". The other port T is closed by a plug screw. In a dry and clean factory environment, this offers sufficient protection against dust etc.

If, however, moisture or aggressive media are present, a pressure-less hose instead of the filter must be installed to connect the Locking Unit KFH with clean atmosphere (e.g. a clean pressureless container). The other port T must be sealed with a plug screw.

⑦ Lock plates keep the Locking Unit released and need to be removed after installation.

⑧ The surface of the housing parts is ZnNi coated.

Technical Data Sheet TI-F50 Locking Units series KFH

For a detailed functional description refer to "Technical Information TI-F10".
Further important practical advice is given in "Operating Manual BA-F51".

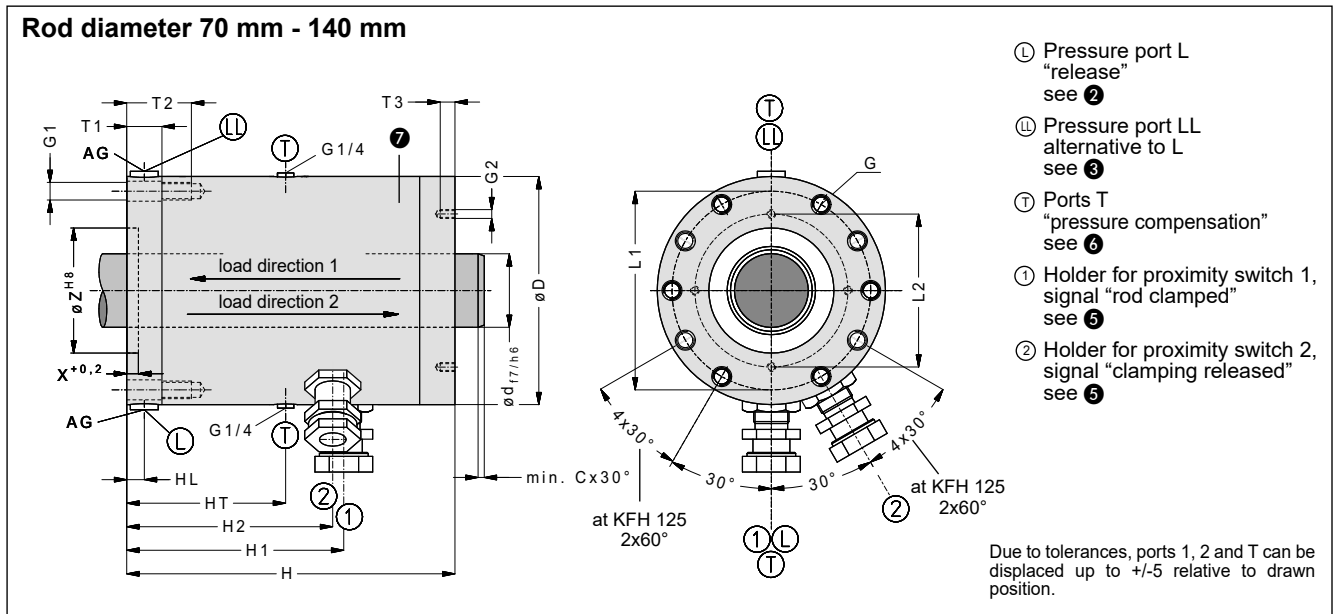

Fig. 4: Dimensions Locking Unit KFH (CAD-files download at www.sitema.com)

Type	ID no.	d	C	F	p	D	H	L1	L2	T1	T2	T3	G1	G2	Z	X	AG	V	HL	H1	H2	HT	Wgt
	(order no.)	mm	mm	kN	bar	mm	mm	mm	mm	mm	mm	mm			mm	mm		cm ³	mm	mm	mm	mm	kg
KFH 70	KFH 070 70	70	4	150	100	225	315	195	160	26	56	16	10 x M16	4 x M8	110	10	G1/4	68	13	192	185	236	80
	80			60																			
KFH 80	KFH 080 70	80	4	150	100	260	393	225	175	30	65	20	10 x M20	4 x M10	125	10	G3/8	95	15	221	214	283	127
	80			60																			
KFH 90	KFH 090 70	90	5	250	130	350	416	300	250	40	90	20	6 x M30	4 x M12	230	10	G3/8	230	24	244.5	235	336	240
	190			100																			
KFH 100	KFH 100 70	100	5	250	130	430	514	370	385	50	95	30	10 x M30	4 x M16	170	10	G3/8	330	30	346.5	334	437	440
	190			100																			
KFH 125	KFH 125 70	125	5	330	100	350	416	300	250	40	90	20	6 x M30	4 x M12	230	10	G3/8	230	24	244.5	235	336	240
KFH 140	KFH 140 70	140	5	600	100	430	514	370	385	50	95	30	10 x M30	4 x M16	170	10	G3/8	330	30	346.5	334	437	440

Subject to modification without prior notice

- ① The nominal holding force F is the minimum holding force for dry or hydraulic-oil wetted rods.
- ② The pressure p is required to release the clamping. The admissible operating pressure is 160 bar.
- ③ As supplied, pressure port LL is plugged by a plug screw. It may be used alternatively to pressure port L and is useful for filling / air-bleeding. We recommend connecting auto-bleeders to the ports which are not in use (not supplied in scope of delivery; available as option - see "Technical Information TI-Z10").
- ④ Hydraulic operating volume
- ⑤ Proximity switch holders are provided for standard inductive proximity switches (M12 x 1 nominal switching distance 2 mm, flush mountable, NO (normally open)).

- For easier service, the proximity switch holders have a depth stop and are pre-adjusted when delivered from the factory. The switches only need to be inserted to the stop and then clamped.
- The proximity switches are not supplied in the standard scope of delivery, but are available as accessories.
- ⑥ Internal volume changes during switching are compensated at ports T. An air filter is fitted to one of the ports T for "breathing". The other port T is closed by a plug screw. In a dry and clean factory environment, this offers sufficient protection against dust etc. If, however, moisture or aggressive media are present, a pressure-less hose instead of the filter must be installed to connect the Locking Unit KFH with clean atmosphere (e.g. a clean pressureless container). The other port T must be sealed with a plug screw.
- ⑦ The surface of the housing parts is ZnNi coated.

Purpose

The Locking Unit KFH is used as an infinitely variable lock on piston rods for cylinders or other clamping rods. The Locking Unit KFH absorbs axial forces in both load directions.

Axial play

The load is held free from axial play in load direction 1.

In standard designs, the load is also free from axial play in load direction 2 as long as the load does not exceed 80 % of the nominal holding force (F). In the case of exceeding, the axial play in load direction 2 is about 0.1 - 0.3 mm.

Operating conditions

The Locking Unit KFH is designed to operate in normal clean and dry workshop atmosphere.

Operation in other environmental conditions is possible if at least port T is connected to a clean and dry atmosphere (e.g. tank). In case of heavy soiling conditions (grinding dust, chips, other liquids, etc.), please contact SITEMA.

Viscous lubricants and grease may reduce the holding force.

The permitted surface temperature is -20°C to +60°C.

Required risk assessment

It must be ensured that the dimensions and arrangement of a Locking Unit KFH used in safety-relevant applications meet the requirements of the risk evaluation EN ISO 12100:2010 and also comply with any further standards and regulations applicable for the intended use. The Locking Unit KFH alone principally cannot form a complete safety solution. It is however suitable to be part of such a solution. Furthermore, all attachments and fixations have to be dimensioned correspondingly. This is generally the duty of the system manufacturer and the user.

Choosing the right type

The table shows the nominal holding force F of the various types. The value of F must be higher than the maximum axial load acting on the rod.

In case vertically moving masses shall be held or stopped or in case other dynamic impact forces occur, an appropriate safety factor must be applied. This factor has to be defined by the user depending on the requirements, but should not be less than 1.5.

Design and attachment of the rod

The Locking Unit KFH will operate correctly only if the rod has a suitable surface:

- ISO tolerance field f7 or h6
- induction hardened min. HRC 56, surface hardening depth:
 - ø up to 30 mm: min. 1 mm
 - ø over 30 mm: min. 1.5 mm
- surface roughness: Rz = 1 to 4 µm (Ra 0.15 - 0.3 µm)
- protection against corrosion, e.g. hard chromium plating: 20 ±10 µm, 800 – 1 000 HV
- lead-in chamfer, rounded:
 - ø 18 mm up to ø 80 mm: min. 4 x 30 °
 - ø over 80 mm up to ø 180 mm: min. 5 x 30 °
 - ø over 180 mm up to ø 380 mm: min. 7 x 30 °

Often, the following standard rods fulfill the above mentioned requirements and can then be used:

- piston rods (ISO tolerance field f7), hard chrome plated
- rods for linear ball bearings (ISO tolerance field h6)

The rod must not be lubricated with grease.

The actual holding force of the Locking Unit KFH is higher than the **nominal holding force (F)** indicated in the data sheets and drawings but will not be higher than twice this value. Therefore, all **fixation elements** carrying the load (rod, its attachment, etc.) have to be dimensioned for at least **2 x F**. Please note that at dynamic loads, the full holding force (2 x F) can occur.

In case of overload, the rod will slip. This does normally not cause any damage to the rod or the clamping unit.

Generally, the basic rod material needs to have sufficient yield strength. In the case of compression-loaded rods, sufficient buckling resistance must be assured.

Mounting information KFH 18 to KFH 60

As supplied, the Locking Unit KFH (rod diameter 18 mm to 60 mm) is blocked in its released state and can be slid over and fixed to the clamping rod easily. After mounting, the transportation spacers must be removed. Please refer to the operating manual for further information.

Pressure fluid

Hydraulic oil (HLP) in accordance with DIN 51524-2:2017 must be used as pressure fluid. Please consult SITEMA before using any other fluids.

Control

In most applications, an actuation as suggested in the drawing below is used.

During every operational cycle, the 3/2-way valve is actuated electrically and releases the Locking Unit KFH. In all other operational conditions including power failure, emergency stop etc., the Locking Unit KFH engages and holds the rod or brakes the load. Likewise, the load is secured when the pressure line breaks.

To prevent possible problems, the rod shall not be driven unless proximity switch 2 indicates the signal "clamping released".

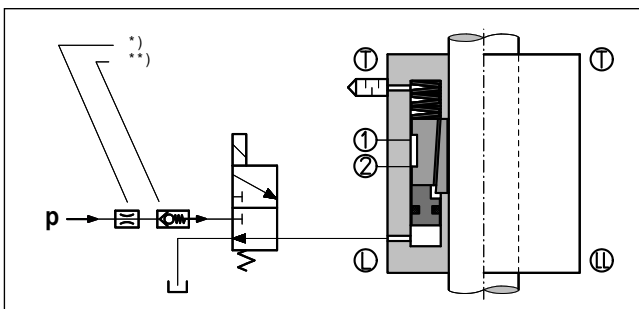

Fig. 5: Schematic diagram of hydraulic circuit

- * In case impact noises due to excess pressure are audible when pressurizing the Locking Unit KFH, these can be suppressed by means of a flow control valve in the p-line.
- ** In case the pressure is not sufficiently constant (e.g. pressure drop at the beginning of a downward stroke), we recommend a check valve in the p-connection of the valve.

⚠ WARNING!

Risk due to slowed discharge of pressure medium!

Slowed discharge of the pressure medium may cause a dangerous situation. The clamping then only locks with a time delay.

- ➊ Make sure that the discharge of the pressure medium from pressure port L is **not** impaired by any additional components.
- ➋ Route all connection lines without any kinks.
- ➌ If there is any danger of kinking, take appropriate precautions (protective tube, thicker hose, etc.).

If a particular quick response time of the Locking Unit KFH is required, the following preconditions must be met:

- short line distances
- fast valve response times
- appropriate control
- large valve and line cross-sections

Regular performance tests

The Locking Unit KFH must be functionally checked at regular intervals. Regular checking is the only way to ensure that the Locking Unit KFH will operate safely in the long run.

Please see the *operating manual* for further details.

Maintenance

The maintenance is limited to the regular performance tests.

Should the Locking Units KFH cease to comply with the required characteristics, the safety for working with the machine or system may no longer be given. In this case the Locking Units KFH must be immediately and professionally repaired by SITEMA.

The Locking Units KFH are safety components. Any repair or refurbishing must be carried out by SITEMA. SITEMA cannot take any responsibility for repairs by another party.