

THE WATER-COOLED INDUSTRIAL RANGE

Energy-efficient compressor systems for air and gases

- › 25 – 420 bar
- › 55 – 1716 m³/h

- › WATER-COOLED
- › PRESSURE-RESISTANT CRANKCASES
- › FOR AIR, NITROGEN, RARE GASES AND CNG

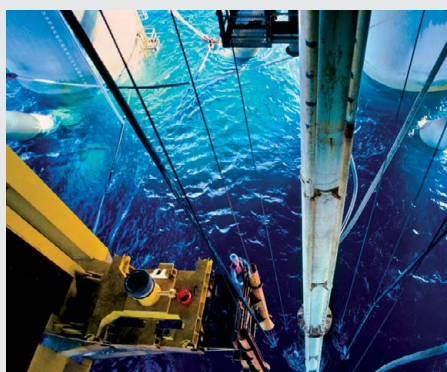
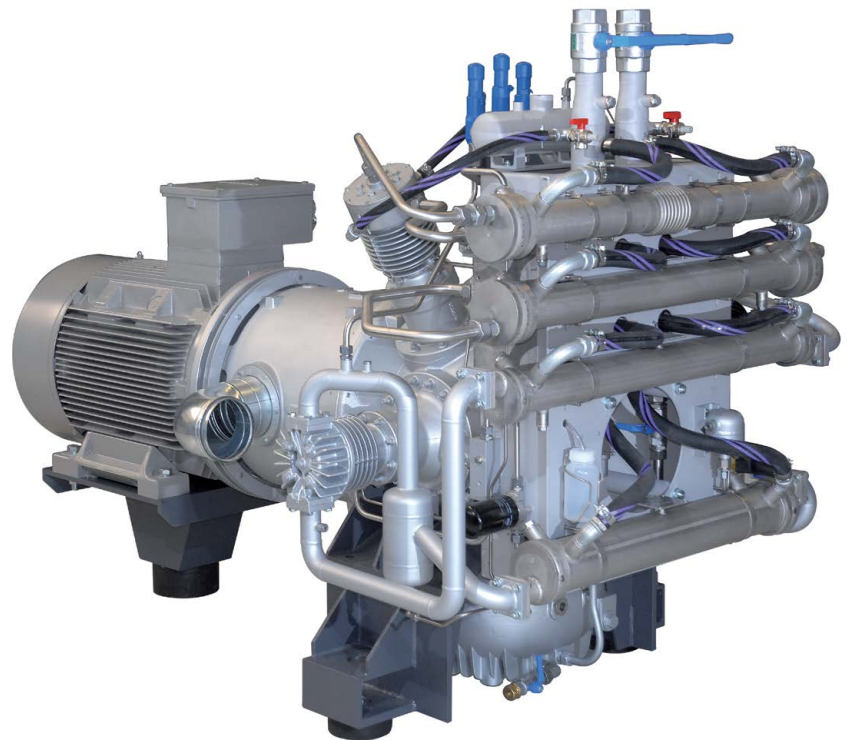

When special applications demand extreme reliability, our water-cooled industrial unit range comes into its own.

Large-dimensioned bearings and sophisticated water cooling, in combination with intelligently designed dry sump lubrication, minimise thermal stress and wear. For reliable and trouble-free operation under extremely difficult ambient conditions, such as mobile use on vehicles and ships, where inclination angles of up to 30° occur.

The unit ranges BK 23 and BK 24

Specialist provider BAUER KOMPRESSOREN has supplied turnkey compressor systems in the high and medium pressure range for more than 65 years. BAUER systems feature modular construction and innumerable configuration possibilities.

They can be perfectly adapted to virtually every customer requirement and enlarged later if required.

› 30–37 kW / 25–420 bar



BK 23 unit, water-cooled, vertical execution

The vertical configuration of the BK 23 range combines minimum floor space requirements with high efficiency.

- › For air, nitrogen, rare gases and natural gas.
- › The vertical execution and the v-belt drive offer compact dimensions while allowing for flexible adaptation to meet the most varied of customer requirements.
- › The pressure-resistant crankcase is provided with dry sump lubrication for better oil cooling and inclinations of up to 30°.
- › Units in booster format are available with up to 16 bar or 38 bar inlet pressure.
- › An air-cooled version in horizontal configuration is optionally available as needed.

› 55–90 kW / 40–350 bar

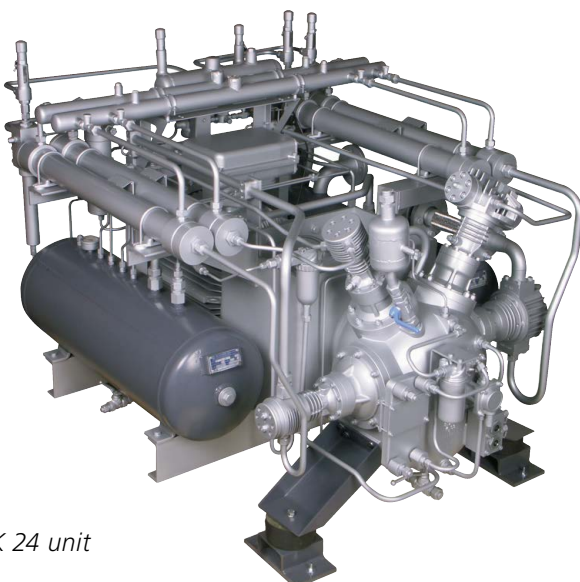

BK 24 unit

The BK 24 range with direct-coupled drive and integrated intake buffer vessels saves precious floor space owing to its compact design.

- › For air, nitrogen, rare gases and natural gas.
- › The electrical drive is directly coupled to the compressor block.
- › The crankcase has a pressure-resistant design which prevents blow-by losses during compression of pre-compressed air and gases.
- › Simple operation, user-friendliness and easy maintenance were the top priorities in design.

The unit ranges BK 26 and BK 52

› 55–160 kW / 25–420 bar



BK 26 unit

The unit ranges BK 26 and BK 52 from BAUER KOMPRESSOREN are available as directly coupled, water-cooled units.

Compared to the four-cylinder BK 26 units, the BK 52 units offer twice as high F.A.D.s due to their eight-cylinder configuration.

- › For air, nitrogen, rare gases and natural gas.
- › The electrical drive is directly coupled to the compressor block.
- › Units in booster format are available with up to 16 bar or 38 bar inlet pressure.
- › A pressure-resistant crankcase is provided with dry sump lubrication for better oil cooling and operation at inclinations of up to 30°.
- › The blocks work with very low compression ratios. In this way, the compression temperatures can be kept at a low level in the different stages, thus reducing maintenance requirements.

› 90–315 kW / 90–350 bar

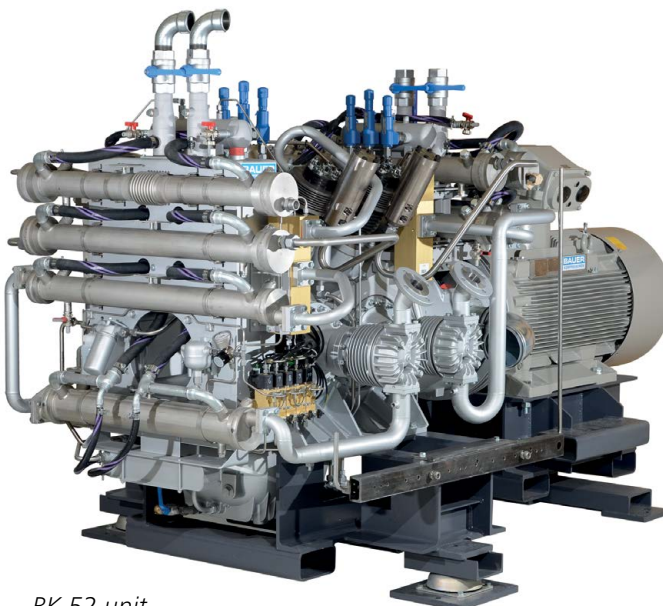

BK 52 unit

- › A special piston construction minimises the usual blow-by. Because of the low losses, a very high efficiency is reached.
- › The crankcase can be combined with a wide variety of cylinders, allowing flexible adaptation to meet customer requirements relating to pressure and F.A.D.
- › A radial fan is installed in the coupling bell housing for cooling purposes. This assures a considerably increased life time of the coupling.

Perfect compressor technology in detail

Our product philosophy consists of developing complete unit concepts in collaboration with our customers, combining the legendary reliability of our compressor systems with very high efficiency in the daily production process.

BAUER ensures high consistency of quality by conducting comprehensive quality assurance measures during and after production, in accordance with DIN EN ISO 9001.

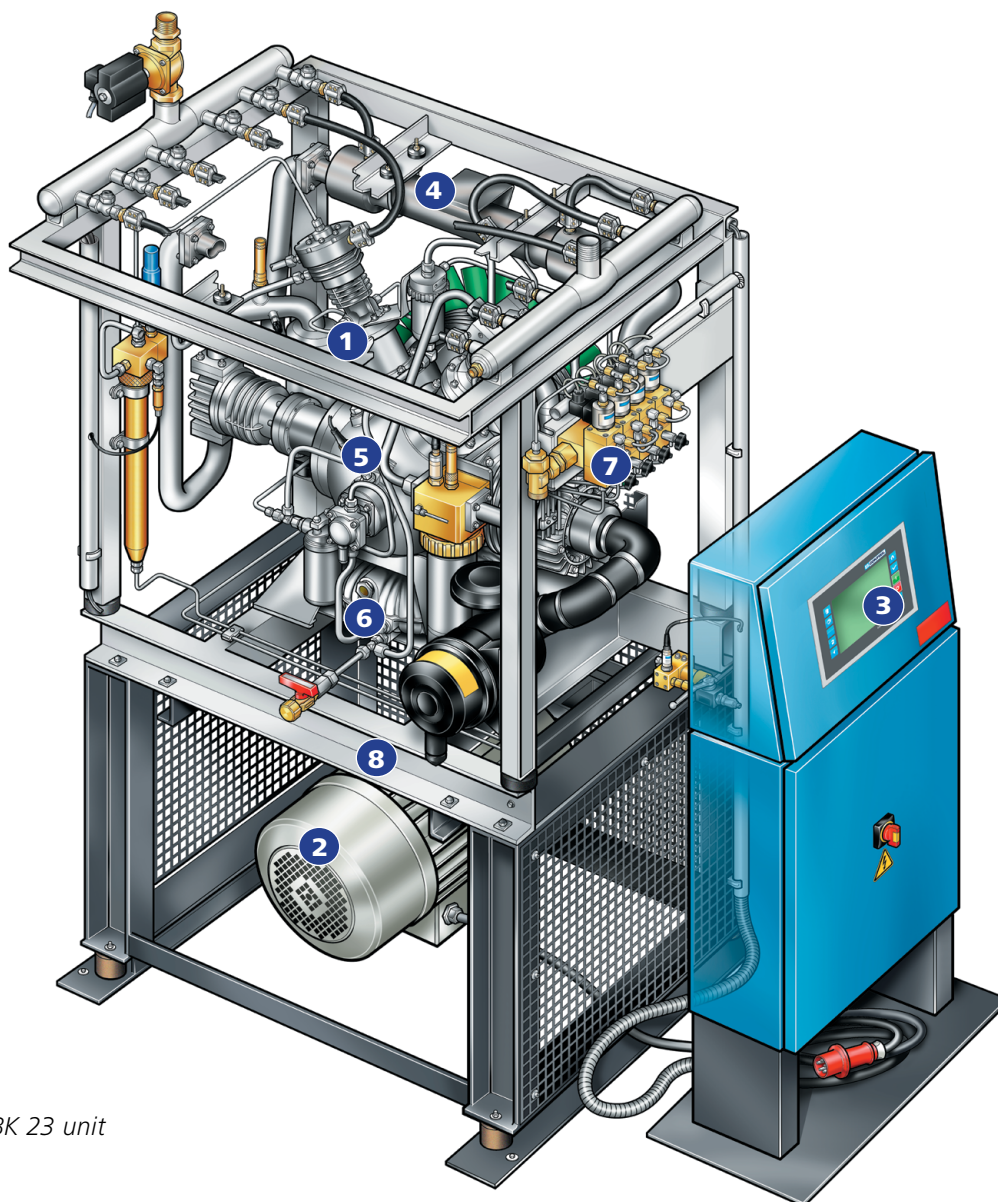

BK 23 unit

- | | | | |
|----------|--------------------|----------|------------------------------|
| 1 | COMPRESSOR BLOCK | 5 | PRESSURE-RESISTANT CRANKCASE |
| 2 | 3-PHASE MOTOR | 6 | OIL SUMP |
| 3 | COMPRESSOR CONTROL | 7 | AUTOMATIC CONDENSATE DRAIN |
| 4 | WATER COOLING | 8 | INTAKE FILTER |

ECONOMIC OPERATION

For particularly economical and safe operation, our units are rigorously optimised for continuous operation and demanding operating conditions.

- › Our compressors and boosters are equipped ex works with particularly economical three-phase motors in accordance with the energy efficiency class IE 2.
- › Thanks to the legendary reliability, longevity and low maintenance requirements of BAUER compressor blocks the operational running costs can be minimised.
- › Moreover, the availability of spare parts for our units for decades to come provides operators with a high degree of investment protection.



Automatic condensate drain

VARIABLE USE

Several drive variants and containerised solutions allow for tailor-made systems for a wide variety of applications.

- › In addition to electrical drives, units for mobile use can be equipped with diesel engines.
- › Containerised installations for mobile or stationary use are also part of our standard program, with either electrical or diesel drive.

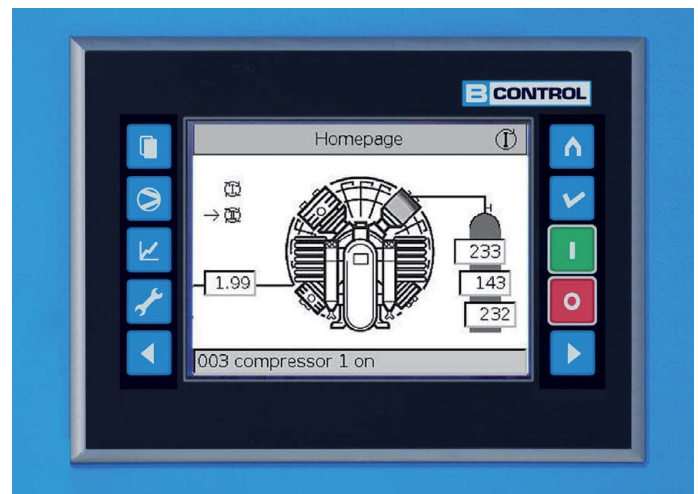

B-CONTROL II compressor control

FULL CONTROL

B-CONTROL II regulates and monitors the complete range of compressor functions.

- › The menu navigation is simple and easy to read and use thanks to the colour touchscreen display.
- › In addition to individual, customer-specific adaptation and extension possibilities, standard interfaces such as USB, Ethernet and Modbus are available.
- › The integrated function of interconnected operation allows for basic load change or even duty/standby operation of up to four compressors, with the B-CONTROL II assigned the master function.
- › The B-CONTROL II comprises a sophisticated maintenance management system. The operator can request the current maintenance state at any time.

INDIVIDUALLY ADJUSTABLE AUTOMATIC CONDENSATE DRAIN

Each single compressor stage is provided with an individually controlled condensate drain valve.

- › In this way, the valve adjustment can be aligned perfectly to the current conditions of use and environment. This ensures optimal operation independent of the local conditions.

The blocks – the heart of the units

UNCOMPROMISED QUALITY

Over 65 years of experience in the construction of medium and high pressure systems and some of the most modern compressor production facilities assure the legendary reliability and longevity of BAUER compressor blocks.

Each individual compressor block undergoes an endurance test, and each unit is submitted to a comprehensive functional check and safety inspection.

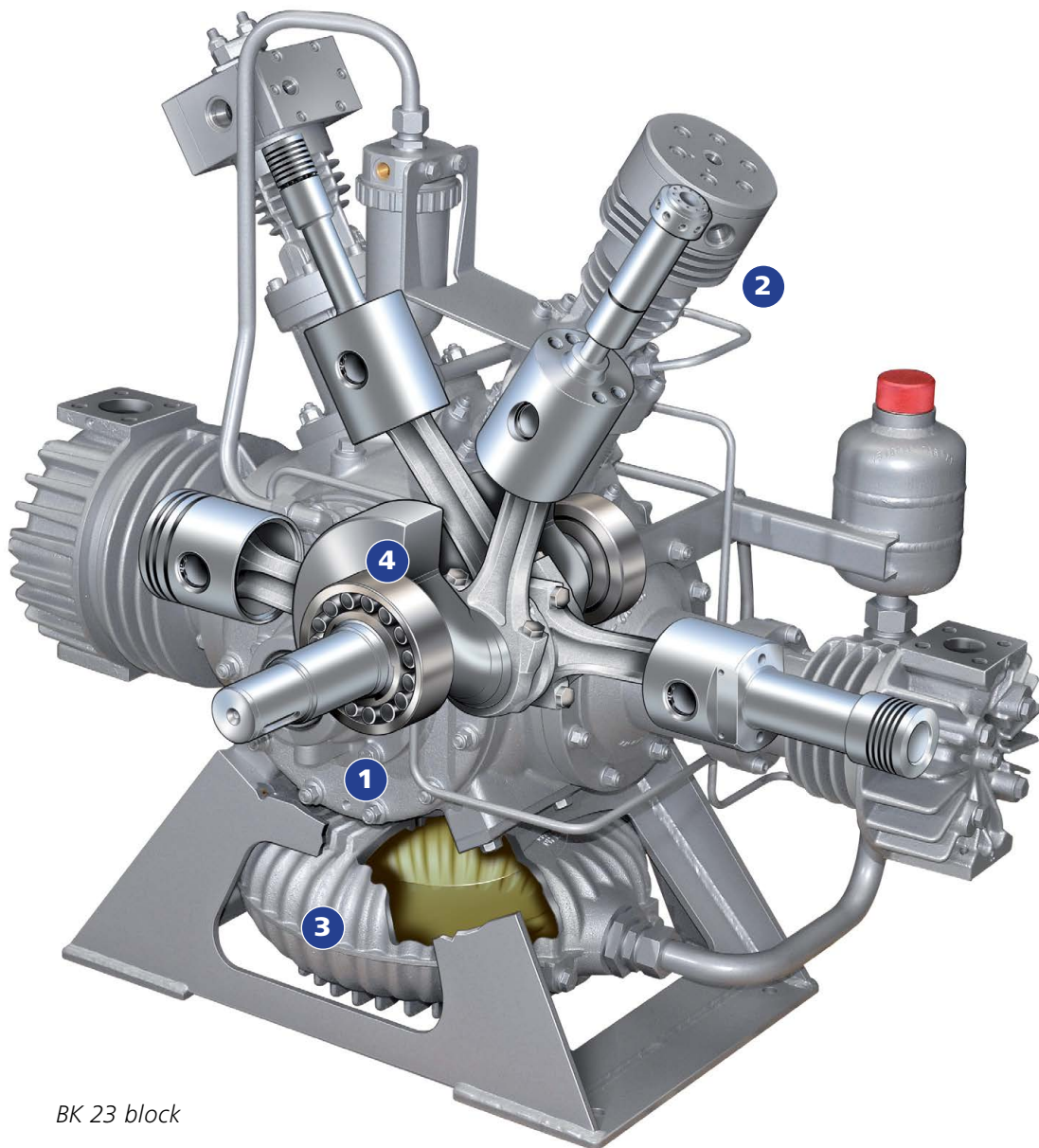

BK 23 block

- 1** The pressure-resistant crankcase allows primary pressures up to 16 bar without any blow-by losses.
- 2** Water-cooled valve heads¹ provide for optimal cooling.
- 3** Dry sump lubrication¹ allows for inclinations of up to 30° in all directions.
- 4** The large-dimensional main bearings are designed for robust operation. ¹ Not the BK 24 block

HIGH DURABILITY

The ingenious cooling system with generously dimensioned coolers in combination with large surface ribbed cylinders, ensures optimum cooling at each of the compressor stages.

- › Honed cylinder surfaces combined with single-acting plunger pistons assure optimum lubrication, thus minimising oil consumption and blow-by.
- › The piston rings are chromed using a special technology. This reduces friction in the cylinder and minimises wear.
- › In addition, the inner surface of the cylinders is plasma nitrated; this hardened surface therefore ensures extra long service life.
- › Vibration-free running enables base-free installation.

EFFICIENT WATER COOLING

As a result of targeted water cooling of the interstage and afterstage coolers and valve heads, nearly 85 % of the heat produced can be absorbed by the cooling water.

- › The BAUER stainless steel heat exchanger safeguards the efficiency and long life of the compressor unit and its optimal functioning and cooling.

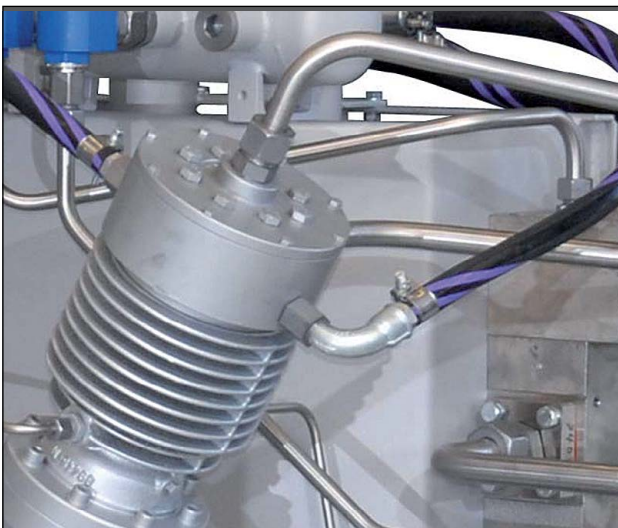

Water-cooled valve head

- › For efficient operating temperature reduction, some block variants are additionally equipped with water cooling for the valve heads.
- › Cost- and maintenance-intensive water jackets are not necessary thanks to the design of BAUER blocks, which minimises heat at the cylinder surface.

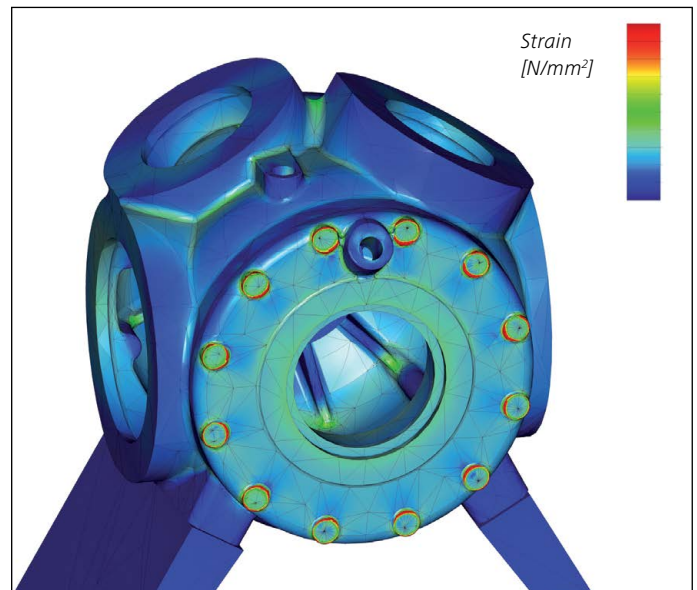

Stress analysis model:
Computer optimised crankcase construction (FEM)

LOW OPERATING COSTS

BAUER compressors feature extremely high levels of efficiency and high-quality, reliable individual components, resulting in economical use.

- › Long maintenance intervals for valve inspection and oil changes keep operating costs for the unit to a minimum and increase availability.
- › Optimum flow cross-sections and valve location ensure efficient cylinder filling and minimal cylinder clearance of the unit at low power consumption and high efficiency.
- › The extremely robust industrial roller bearings are rated for continuous operation and heavy-duty operating conditions.

Dimensions and configurations

BK 23 range – Vertical design

Dimensions in mm (approx.):
 Length: 1360 Width: 875 Height: 2040

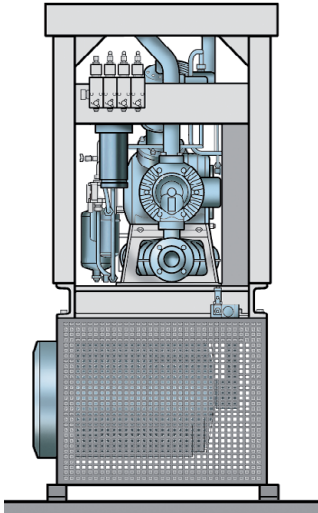

BK 24 range – Horizontal design

Dimensions in mm (approx.):
 Length: 1990 Width: 1470 Height: 1380

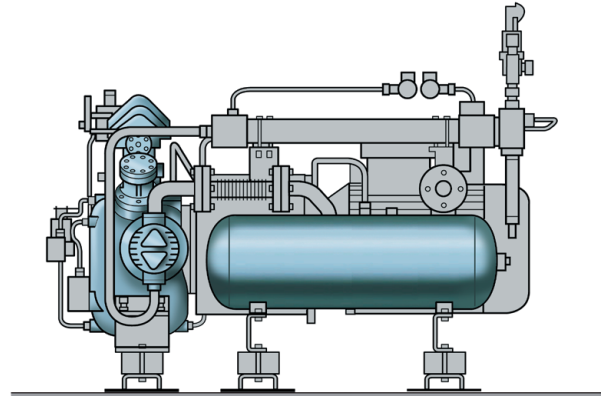

BK 26 range – Horizontal design

Dimensions in mm (approx.):
 Length: 2460 Width: 1505 Height: 1800

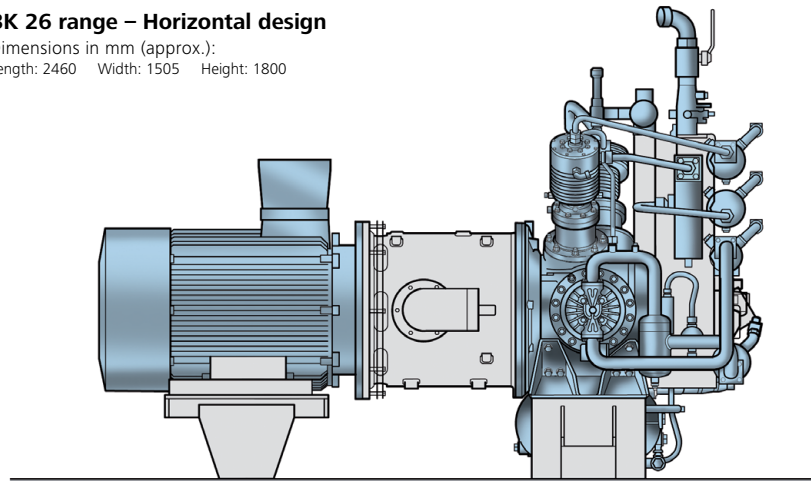

BK 52 range – Horizontal design

Dimensions in mm (approx.):
 Length: 3200 Width: 1780 Height: 1960

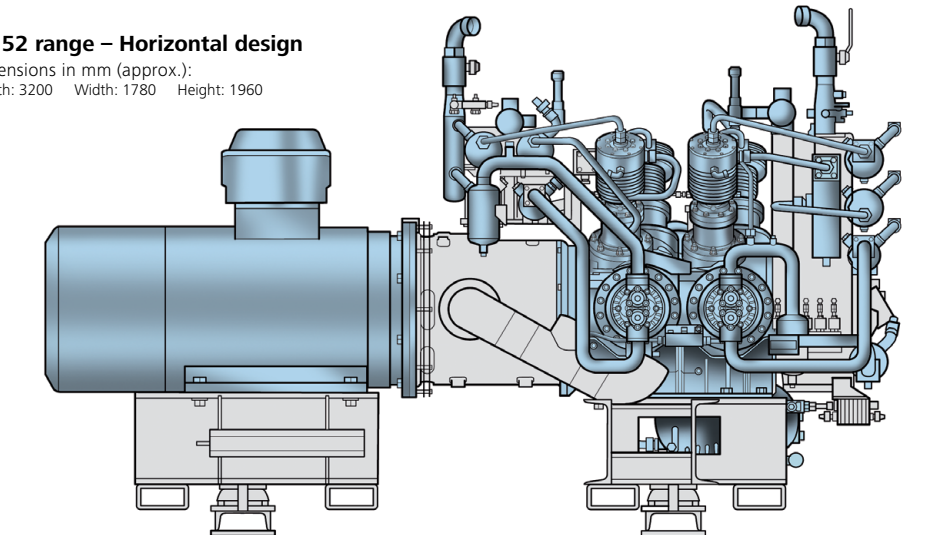

Technical Data

Model	F.A.D. ¹			Intake pressure	Final pressure		Number of stages	Speed	Motor power	Power consumption ²	Net weight
					min.	max.					
	l/min	m ³ /h	cfm	bar _(g)	bar	bar		min ⁻¹	kW	kW	kg
Compressor, 25 to 63 bar											
B 26.4-55	3570	214	126	atm.	25	63	3	985	55	53	2710
B 26.4-90	5400	324	191		25	63		1485	90	80	2960
Compressor, 90 to 350 bar³											
IB 23.0-30	1300	78	46	atm.	90	350	4	1210	30	27	1150
IB 23.0-37	1500	90	53		1420	37		32	1150		
I 24.0-55	2100	126	74	atm.	90	350	4	1485	55	45	1500
I 26.0-55	2250	135	79	atm.	90	350	4	985	55	48	2690
I 26.0-75	3400	204	120					1485	75	72	2950
I 52.0-110	4500	270	159	atm.	90	350	4	985	110	96	4000
I 52.0-160	6800	408	240					1485	160	144	4000
Booster, 25 to 100 bar											
GIB 23.8-37	2800	168	99	4	25	40	2	1140	37	20	1170
	3920	235	138	6	30	50				26	
	5050	303	178	8	40	63				33	
	6180	371	218	10						36	
GIB 23.7-37	2060	124	73	4	25	40	2	1140	37	15	1160
	2900	174	102	6	35	60				21	
	3700	222	131	8	40	80				28	
	4530	272	160	10	50					30	
	5360	322	189	12						32	
GIB 24.20-90	9800	588	346	8	40	80	2	1485	90	71	1770
	12000	720	424	10	50	100				87	
GIB 26.6-160 ³	13000	780	459	4	15	20	1	1485	160	67	3530
	18200	1092	643	6	15	25				84	
	23400	1404	826	8	20	30				101	
	28600	1716	1010	10		40				133	
GIB 26.8-160 ³	9200	552	325	4	25	40	2	1485	160	66	3500
	13000	780	459	6	30	50				87	
	16600	996	586	8	40	63				108	
	20400	1224	720	10		75				133	
GIB 26.7-132 ³	7000	420	247	4	25	50	2	1485	132	62	3360
	9800	588	346	6	35	63				77	
	12600	756	445	8	40	100				106	
	15400	924	544	10	50					118	

¹ Measured acc. to ISO 1217
 Values valid for air and nitrogen at 50Hz
 Correction factor natural gas: FAD air x 0.9
 Correction factor helium: FAD air x 0.8
 Correction factor argon: FAD air x 0.95
 Other gases on request

² At max. final pressure
 Values valid for air and nitrogen at 50Hz
 Correction factor natural gas: x 0.9
 Correction factor helium: x 1.06
 Correction factor argon: x 1.12

³ Not suitable for helium/argon

For rare gases some restrictions partly apply to intake and final pressure.

Technical Data

Model	F.A.D. ¹			Intake pressure	Final pressure		Number of stages	Speed	Motor power	Power consumption ²	Net weight
					min.	max.					
	l/min	m ³ /h	cfm	bar _(g)	bar	bar		min ⁻¹	kW	kW	kg
Booster, 90 to 350 bar											
GIB 23.10-37	1330	80	47	2	90	200	4	1140	37	19	1150
	1780	107	63	3	150	300				26	
	2220	133	78	4	200	350				32	
	2440	146	86	4,5						35	
GIB 23.12-37	1550	93	55	4,5	90	200	4	1140	37	19	1180
	1970	118	70	6	150	300				25	
	2530	152	89	8	200	350				31	
	3100	186	109	10						35	
GIB 23.13-37	1970	118	70	8	150	200	4	1140	37	20	1180
	2400	144	85	10		300				26	
	2850	171	101	12	200	350				31	
	3300	198	116	14						34	
GIB 23.14-37	1850	111	65	16	150	250	3	1140	37	18	1180
	2280	137	80	20		300				22	
	3370	202	119	30	200	350				31	
	4250	255	150	38						35	
GIB 24.11-75 ³	2200	132	78	1	90	200	4	1485	75	35	1660
	3200	192	113	2	150	300				51	
	4200	252	148	3	150	350				64	
	5240	314	185	4	200					74	
GIB 24.12-75 ³	2500	150	88	4	120	300	4	1485	75	35	1660
	3500	210	124	6	150	350				46	
	4500	270	159	8	200	350				55	
	5500	330	194	10	220					63	
GIB 24.13-55 ³	2480	149	88	8	150	350	4	1485	55	31	1500
	3300	198	117	11		350				37	
	4140	248	146	14	200	350				43	
	4700	282	166	16	250					47	
GIB 26.10 -132	4900	294	173	2	90	200	4	1485	132	71	3350
	6700	402	237	3	150	350				103	
	8500	510	300	4	200					123	
	9400	564	332	4,5		131					

¹ Measured acc. to ISO 1217
 Values valid for air and nitrogen at 50Hz
 Correction factor natural gas: FAD air x 0.9
 Correction factor helium: FAD air x 0.8
 Correction factor argon: FAD air x 0.95
 Other gases on request

² At max. final pressure
 Values valid for air and nitrogen at 50Hz
 Correction factor natural gas: x 0.9
 Correction factor helium: x 1.06
 Correction factor argon: x 1.12

³ Not suitable for helium/argon

For rare gases some restrictions partly apply to intake and final pressure.



Model	F.A.D. ¹			Intake pressure	Final pressure		Number of stages	Speed	Motor power	Power consumption ²	Net weight	
					min.	max.						approx.
	l/min	m ³ /h	cfm	bar _(g)	bar	bar	min ⁻¹	kW	kW	kg		
Booster, 90 to 350 bar												
GIB 26.12-132	5550	333	196	4,5	90	250	4	1485	132	72	3350	
	7000	420	247	6	150	350				96		
	9000	540	318	8	200					110		
	10200	612	360	10						117		
GIB 26.13-132	8050	483	284	10	150	350	4	1485	132	90	3350	
	9500	570	335	12						104		
	11000	660	388	14						116		
	11700	702	413	15						121		
GIB 26.14-110	4200	252	148	17	150	250	3	1485	110	48	3350	
	5700	342	201	20		350				65		
	8400	504	297	30						200		81
	10850	651	383	38						250		92
GIB 52.10-315	9800	588	346	2	90	200	4	1485	315	142	4800	
	13400	804	473	3	150	350				206		
	17000	1020	600	4	200					246		
	18800	1128	664	4,5						262		
GIB 52.12-250	11100	666	392	4,5	90	250	3	1485	250	144	4330	
	14000	840	494	6	150	350				192		
	18000	1080	636	8	200					220		
	20400	1224	720	10						234		
GIB 52.13-250	16100	966	569	10	150	350	4	1485	250	180	4330	
	19000	1140	671	12						212		
	22000	1320	777	14						200		233
	23400	1404	826	15						250		242
GIB 52.14-200	8400	504	297	17	150	250	3	1485	200	94	4200	
	11400	684	403	20		350				118		
	16800	1008	593	30						200		156
	21700	1302	766	38						250		176
Booster, 200 to 420 bar												
GIB 23.5-37 ³	2400	144	85	10	200	420	4	1140	37	30	1180	
	2850	171	101	12						33		
GIB 26.5-132 ³	6500	390	230	6	200	420	4	1485	132	90	3400	
	8300	498	293	8	250					107		
	9200	552	325	9						115		

The BAUER industrial program

BAUER KOMPRESSOREN

THE AIR-COOLED INDUSTRIAL RANGE

Efficient compressor systems for air and gases

- > 30 – 500 bar
- > 39 – 408 m³/h
- > AIR-COOLED
- > V-BELT DRIVEN
- > FOR AIR, NITROGEN AND RARE GASES

Companies that rely on absolute operating safety and investment security in their inspection or production processes have confidence in 65 years of BAUER-experience in High-Pressure Systems Technology. Whatever application you want to realize with medium or high pressure air or nitrogen, we support you in every respect. Our service includes project planning, installation of complete turn-key systems, certifications of all kinds and, of course, a reliable after sales service as well as a guaranteed spare parts supply for decades - worldwide.

www.bauer-kompressoren.de

BAUER KOMPRESSOREN

THE G RANGE

Compressor units for rare gases

- > 25 – 350 bar
- > 85 – 24.800 l/min
- > FOR HELIUM AND ARGON
- > AIR AND WATER-COOLED
- > MEDIUM AND HIGH PRESSURE

High-performance complete system solutions for reliably compressing, purifying, storing, distributing and recovering rare gases.

The compressors from BAUER are especially modified for the treatment of rare gases. Filter systems from BAUER provide for a consistently high gas quality. The B-CONTROL compressor control and an optional noise absorbing construction provide a high degree of user convenience. For special application conditions, BAUER also offers container solutions.

www.bauer-kompressoren.de

BAUER KOMPRESSOREN

MINI - VERTICUS III

Compact Air and Nitrogen Compressor

- > 85 – 1550 l/min
- > 25 – 350 bar
- > SOUNDPROOF
- > COMPACT AND POWERFUL

The MINI-VERTICUS III, an approved unit in a modern design, that sets new standards in technical excellence and ergonomics. The perfect unit for small rooms and industrial applications - either as a booster or compressor drawing air from the atmosphere. Designed for long life and low operating costs.

www.bauer-kompressoren.de

BAUER KOMPRESSOREN

VERTICUS 5 INDUSTRY

The Compressor System for Air and Nitrogen

- > 85 – 1980 l/min
- > 25 – 500 bar
- > FOR MEDIUM AND HIGH PRESSURE
- > PROVEN RELIABILITY
- > WIDE VARIETY OF USES

The heavy duty system with excellent reliability for compressing air and nitrogen (N₂). The BAUER B-CONTROL combines fully automatic start-stop operation with maximum user confidence. The optional BAUER purification systems offer high gas and air purity. Units available in standard open or Super Silent version.

www.bauer-kompressoren.de

BAUER KOMPRESSOREN

THE P-PURIFICATION SYSTEM

For air and gas of the highest quality

- > 100 – 3500 l/min
- > 90 – 500 bar
- > FOR PURIFICATION OF AIR, N₂ AND RARE GASES
- > GENERATES PURE BREATHING AIR, INDUSTRIAL AND MEDICAL AIR

The P-purification system from BAUER ensures reliable air and gas purification for the application in question. No matter whether you count on the purest breathing air as a diver or firefighter or if you have to trust in perfectly purified process air in the industrial field. More than 65 years of BAUER experience in purification, intensive research and the toughest material tests guarantee outstanding quality and high safety.

www.bauer-kompressoren.de

BAUER KOMPRESSOREN

THE SECCANT RANGE

Regenerative dryer for air and gas

- > 1500 – 3500 l/min
- > 90 – 420 bar
- > EASY INTEGRATION
- > B-CONTROL COMPRESSOR CONTROL
- > OPTIONAL FILTER MONITORING
- > GAS-TIGHT HELIUM CONSTRUCTION

Drying air and gases economically. At high pressures and high throughput. This is the strong point of the SECCANT regenerative dryer from BAUER. For dehumidifying and purifying air, nitrogen and rare gases, the SECCANT regenerative dryers offer a tailor-made system solution for every application. For solutions requiring absolute continuous operation, where the process do not permit any interruption, can also be used in combination with a bypass filter system from BAUER. By means of an external control room, online control and online monitoring of SECCANT and the compressor unit can be implemented.

www.bauer-kompressoren.de

