



# ProShape

Module for processing  
oval PET containers



## New options for stretch blow moulding

You would like to produce oval or asymmetrical PET containers? On a KRONES or KOSME stretch blow moulder? And that in perfect quality? The ProShape module renders it possible. It enables selective tempering of the preforms to blow mould perfect containers afterwards.

### At a glance

- Production of oval or asymmetrical, as well as cylindrical containers for
  - CSD
  - non-carbonated water
  - non-beverage products
- Machine size between 4 and 22 cavities
- Output of up to 50,600 containers per hour
- Can be combined with KRONES and KOSME technology
  - Stretch blow moulders
  - Blow moulder/filler blocks





## Technical features

- Integration of the module between linear oven and blowing wheel
- Creation of a precise temperature profile for each preform
- Basis for optimum material distribution and thereby the implementation of light weighting
- Camera system for the detection of orientation marks and the automatic preform orientation
- Production of cylindrical bottles by simply deactivating the ProShape module

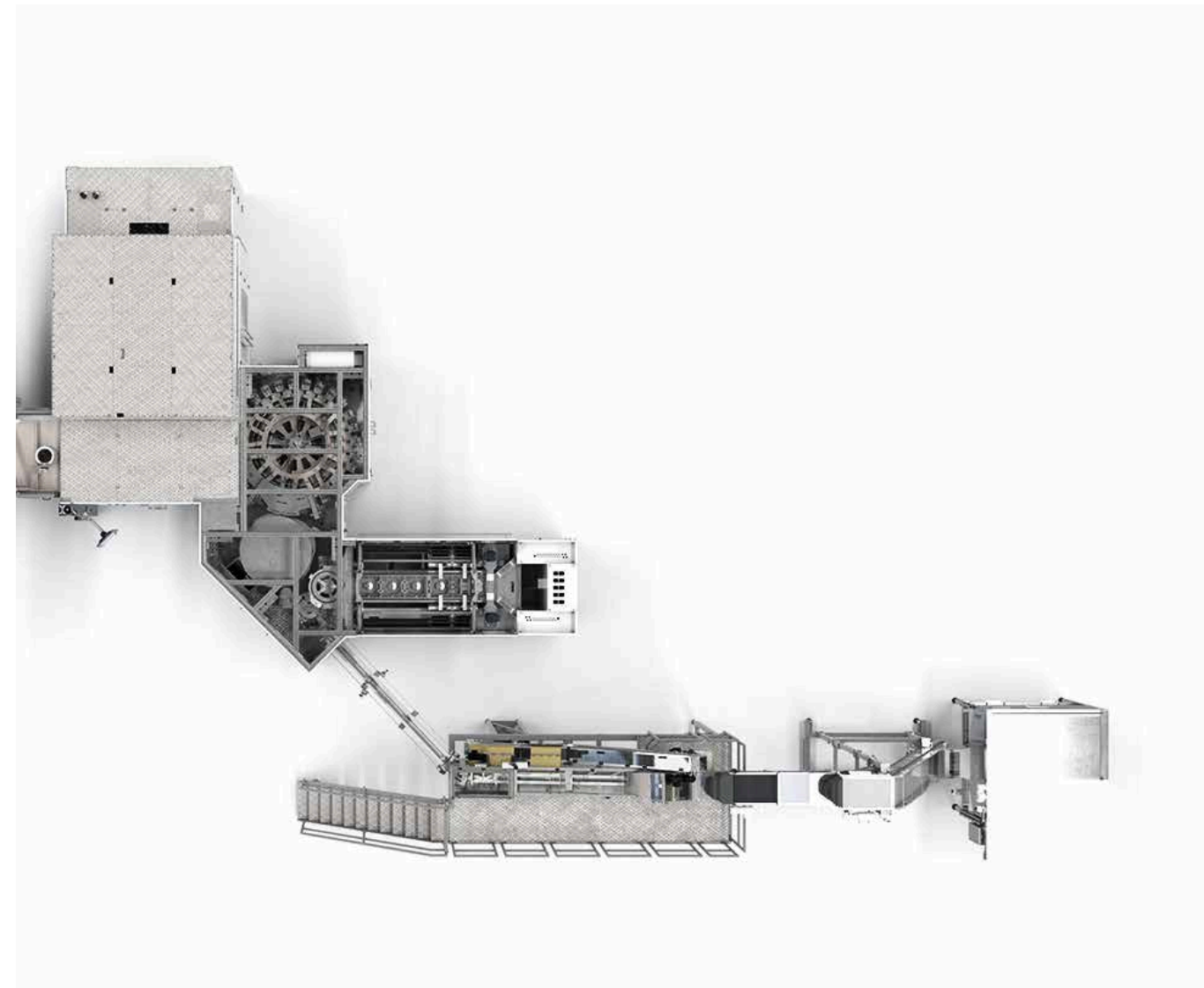



## The process steps in detail: detection and orientation

### Detection

- Well-proven technology from the KRONES inspection technology
- Imaging and analysis
- The software detects the orientation mark and calculates the orientation angle

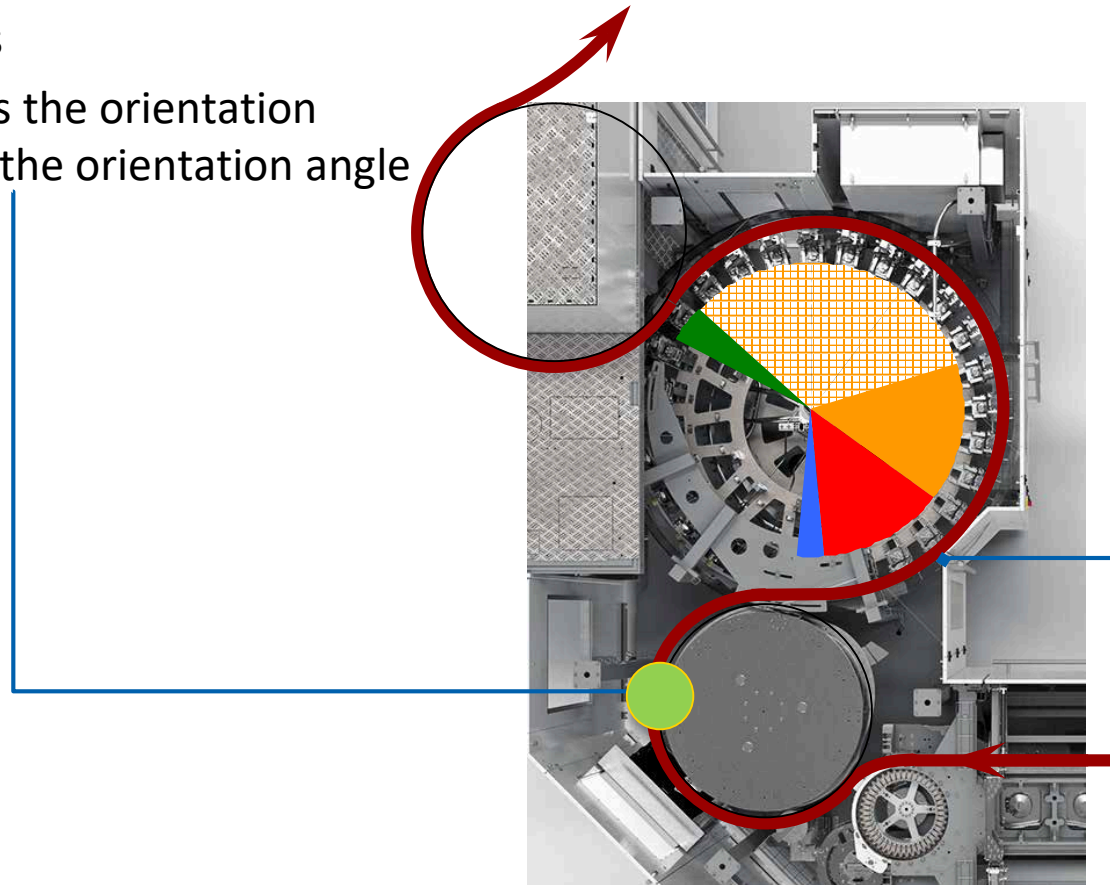

### Orientation

- Support on 5-point mandrels as in the linear oven
- Orientation by means of individually controlled stepper motors
- Preform handling with actively controlled transfer clamps

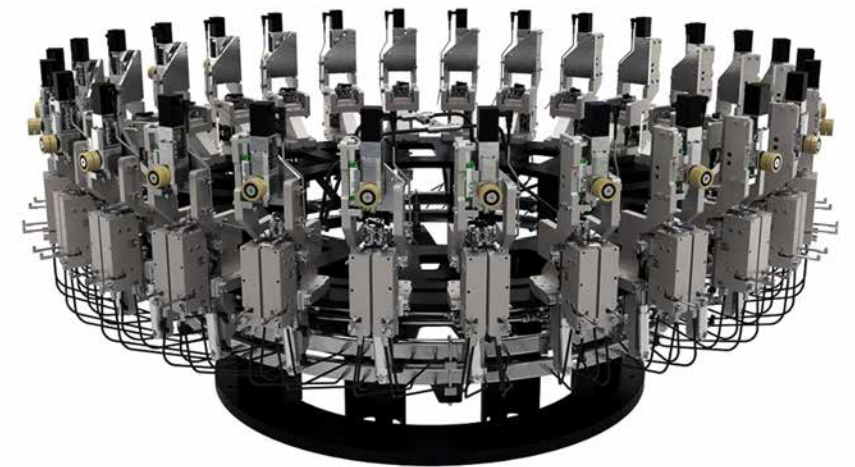





## The process steps in detail: compensation, re-orientation and profiling

### Profiling

Tempering plates with

- exactly adjusted shape to suit the required profile
- precisely adjustable temperature

### Compensation and re-orientation

- Creation of a perfect temperature profile adjusted to suit the future bottle shape
- Optimum adjustment of the transfer to the blowing station

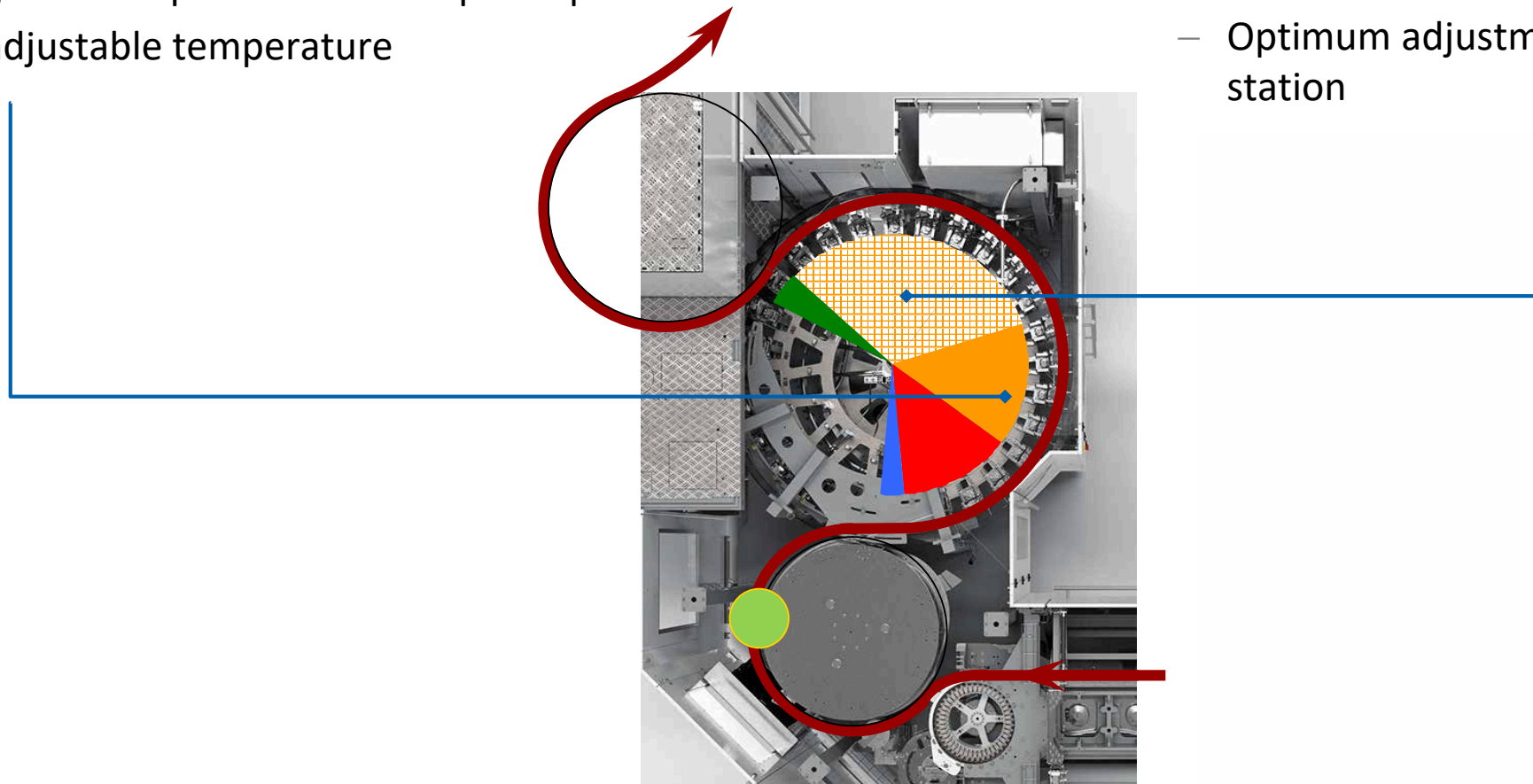



## Benefits to you

### **High performance**

High speeds are no problem for ProShape: The process enables station outputs of up to 2,300 bottles per hour.

### **Precise tempering for perfect shapes**

The ProShape process operates extremely precisely and allows extremely small tolerances. This way, each preform obtains a precise temperature profile with exactly defined temperature zones. This results in precisely shaped bottles.

### **Best material distribution**

Extensive lab tests have shown, that ProShape achieves much better material distributions than comparable systems of other manufacturers.

### **Material savings**

ProShape utilises light weighting even for containers with oval and asymmetrical shapes. Selective tempering enables areas with thick and thin side-walls to be positioned close to each other which, in turn, results in very stable containers, even if the weight is very low.

### **Containers with round and oval bases on one machine**

If necessary, ProShape can be deactivated very easily. This way, changing between standard production and ProShape mode is possible as required.



## Everything from a single source

### **Training sessions at the KRONES Academy – trained personnel increases your line efficiency**

The versatile training offer ranges from operation, servicing and maintenance to management training. We will gladly also establish your individual training programme.

### **KIC KRONES cleaning agents make your machine shine**

Only if the production environment is immaculate, can your product be brilliant. KIC KRONES provides you with the optimum cleaning agents and disinfectants for each individual production step.

### **Lubricants from KIC KRONES for every production step**

Whether for gears, chains or central lubrication systems – our greases and oils are true all-round talents. You can reach every lubrication point, protect your line and provide gentle treatment for your product thanks to our products' suitability for food.

### **KRONES Lifecycle Service – partner for performance**

Also after having purchased a new machine, KRONES will take care of your line; the LCS experts are always ready to consult you and translate your goals and wishes into optimal LCS solutions.





Digitalisation



Process  
technology



Bottling and  
packaging equipment



Intralogistics



Lifecycle  
Service

We do more.

 **KRONES**