

Haas ST-30 Y-Axis Lathes



The High-Performance Turning Centers

3 400-rpm high-torque spindle;
22,4 kW vector drive

ISO standard G-code programming
through the user-friendly,
full-function Haas CNC control
or use the optional Intuitive
Programming System



4 500-rpm high-speed spindle;
22,4 kW vector dual drive

± 51 mm" Y-axis travel for off-center
milling, drilling and tapping

Belt-type chip conveyor available

Warranty: 1 Year Parts and Labor

[Standard Features]

- 254 mm Hydraulic Chucking System
- A2-6 Spindle Nose
- 76 mm Bar Capacity
- ± 51 mm Y-Axis Travel
- Live Tooling with C Axis
- 15" Color LCD Monitor w/USB Port
- 1 MB Program Memory
- Rigid Tapping
- Made in the USA

[ST-30Y]

- 457 x 584 mm Max Capacity
- 3 400-rpm Spindle
- 22,4 kW Vector Drive
- 12-Station BOT/VDI Turret

[ST-30SSY]

- 406 x 584 mm Max Capacity
- 4 500-rpm Spindle
- 22,4 kW Vector Drive
- 24-Station BOT/VDI Turret

[Options] partial list

- Programmable Hydraulic Tailstock
- High-Pressure Coolant Systems
- Automatic Tool Presetter System
- Belt-Type Chip Conveyor
- Ethernet Interface
- Haas Intuitive Programming System
- Servo Bar Feeder
- Parts Catcher



Haas Automation Europe | www.HaasCNC.com | +32 2 522 99 05 | Made in U.S.A.

Specifications subject to change without notice. Not responsible for typographical errors. Machines shown with optional equipment.

ST-30 Y-Axis Lathes

The High-Performance Turning Centers



The ability to turn and mill complex parts and perform multiple operations on a single machine increases throughput, reduces handling, and improves part accuracy.

The Haas ST-30 Series Y-axis turning centers provide 101 mm of Y-axis travel (± 51 mm from the centerline) for off-center milling, drilling, and tapping, and come standard with high-torque live tooling and a servo-driven C axis for versatile 4-axis capability. They are available in standard and Super Speed configurations.

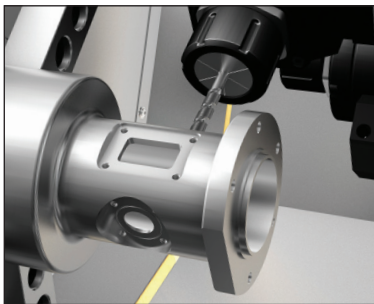

Generous Y-axis travel combined with high-torque live tooling and C axis motion allow multiple operations in a single setup to reduce part handling and increase accuracy.

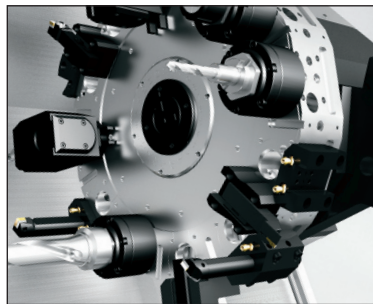

Both Y-axis machines are equipped with a hybrid turret that accepts BOT tools, OD tools and VDI 40 tools. The ST-30Y has a 12-station turret, and the ST-30SSY has a 24-station turret.

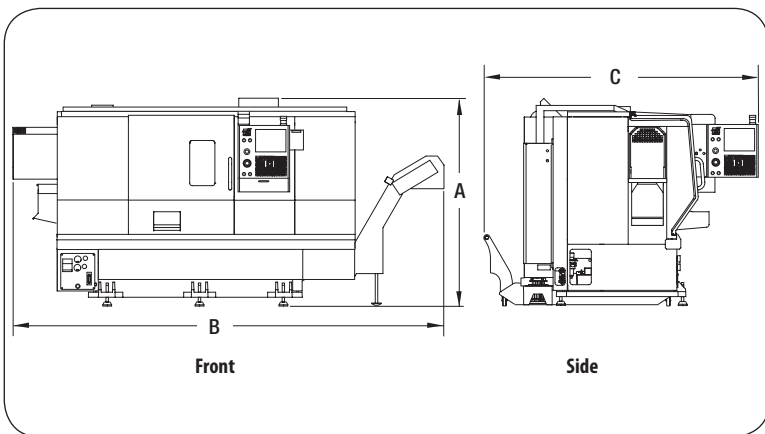

Operating Dimensions ST-30Y/ST-30SSY

A.	Max Operating Height	2 108 mm
B.	Max Operating Width**	4 521 mm
C.	Max Operating Depth***	3 048 mm

** With gearbox option, add 305 mm.

***With control swung forward and coolant tank in place. Additional 381 mm required to open rear service panel.

[Specifications]

Capacities	ST-30Y	ST-30SSY
Chuck Size	254 mm	254 mm
Max Cutting Dia.	457 mm	406 mm
Max Cutting Length without workholding	584 mm	584 mm
Std. Bar Capacity	76 mm	76 mm

Spindle

Max Speed	3 400 rpm	4 500 rpm
Max Motor Rating	22,4 kW	22,4 kW
Max Torque	407 Nm @ 500 rpm	373 Nm @ 600 rpm
Max Torque w/ Opt. Gearbox	1 356 Nm @ 150 rpm	—
Spindle Nose	A2-6	A2-6
Spindle Bore	88,9 mm	88,9 mm

Swing Diameter

Over Front Apron	806 mm	806 mm
Over Cross Slide ¹	527 mm	527 mm
Over Tailstock	584 mm	584 mm

Travels & Feeds

X Axis	318 mm	318 mm
Y Axis	± 51 mm	± 51 mm
Z Axis	584 mm	584 mm
X-Axis Rapids	12 m/min	12 m/min
Y-Axis Rapids	12 m/min	12 m/min
Z-Axis Rapids	24,0 m/min	30,5 m/min

General

Power – 3-phase	354 - 488 VAC	354 - 488 VAC
-----------------	---------------	---------------

¹ With Y-axis at 0



Prices and specifications subject to change without notice.
Not responsible for typographical errors.
Machines shown with optional equipment.