

EVERDRY®

**HEAT-REGENERATED
ADSORPTION DRYERS**



THE SOLUTION FOCUSES ON THE APPLICATION REQUIREMENTS

For this reason BEKO offers application-optimized products for the treatment of compressed air. Refrigeration dryers, adsorption dryers and membrane dryers have been part of our product spectrum for many years.

Our extensive product range also includes heat-regenerated EVERDRY® adsorption dryers. EVERDRY® stands for customer-oriented plant engineering tailored to the specific operational requirements on the basis of highly efficient, standardized concepts.

Our familiarity with the requirements of the different sectors of industry, many years of experience in plant engineering, high-quality product and system solutions, and our well established international BEKO sales and service network: these are the key components that enable us to offer our customers a unique performance package.

Consulting, engineering, installation and service for EVERDRY® adsorption dryers are available worldwide through our BEKO sales and service organizations or our qualified partners.



**+ 1: APPLICATION-ORIENTED
PLANT ENGINEERING**

**+ 2: ENERGY-OPTIMIZED
CONCEPTS**

**+ 3: RELIABLE
PROCESS CONTROL**

**+ 4: COMPREHENSIVE
SOLUTION INSTEAD OF
BIT-BY-BIT APPROACH**

**+ 5: ADDED VALUE
THANKS TO
SPECIALIST KNOW-HOW**



EVERDRY® - THE CUSTOMIZED SOLUTION TO SATISFY ALL CRITERIA

EVERDRY® offers standardized plant concepts with many variation options. This makes it possible to meet the complex requirements of compressed air drying extremely cost-effectively for all flow rates.

For exceptional, customer-specific requirements we develop individual solutions.

In brief: The EVERDRY® concept is not restricted to what is available; it owes its success to solution-oriented, optimal technology.

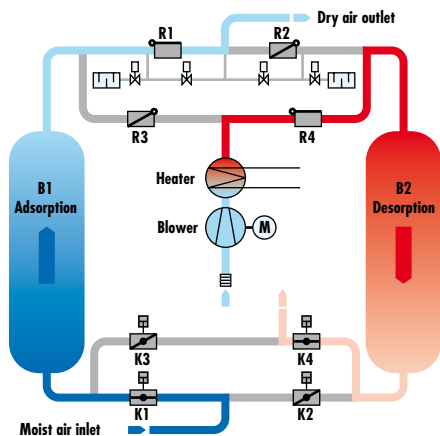

EVERDRY® FRP

- Desorption using heated blower air
- Cooling using partial flow of expanded dry air
- Suitable for universal application; starting basis for system variants

Series EVERDRY® FRP	580 40.000 m³/h	Performance range	High process reliability
DTP up to -40 °C	All climate zones		
Heat- regenerated	Investments Operation		

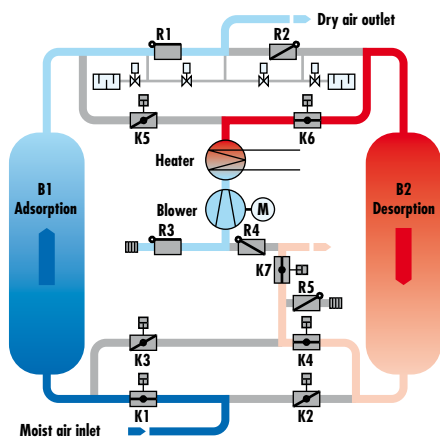

EVERDRY® FRA

- Desorption using heated blower air
- Cooling using blower air (ambient air)

Series EVERDRY® FRA	580 40.000 m³/h	Performance range	ZERO PURGE
DTP up to -40 °C	Temperate climate		High process reliability
Heat- regenerated	Investments Operation		

EVERDRY® - THE CUSTOMIZED SOLUTION TO SATISFY ALL CRITERIA

EVERDRY® FRL

- Desorption using heated blower air
- Cooling using blower air in a closed circuit (loop)
- Designed for critical ambient conditions

Series EVERDRY® FRL	580 40,000 m³/h	Performance range	ZERO PURGE
DTP up to -70 °C	All climate zones	High process reliability	
Heat-regenerated	Investments Operation	Loop	

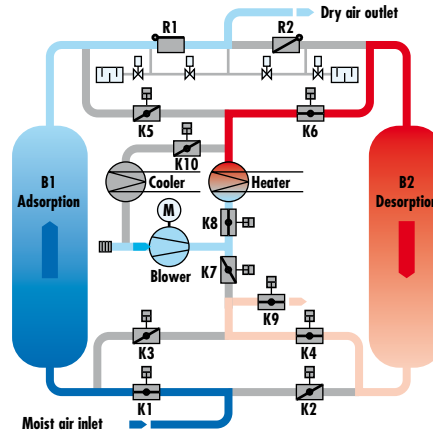

EVERDRY® HOC

This energy-saving concept utilizes compression heat.

Wherever oil-free compressed air is being produced you can profit from the advantages of our HOC series. The main design principle: the heat generated when the air is being compressed is used for the removal (desorption) of the adsorbed water. The energy saving is tremendous and represents a convincing argument in favour of EVERDRY® with compression heat utilization.

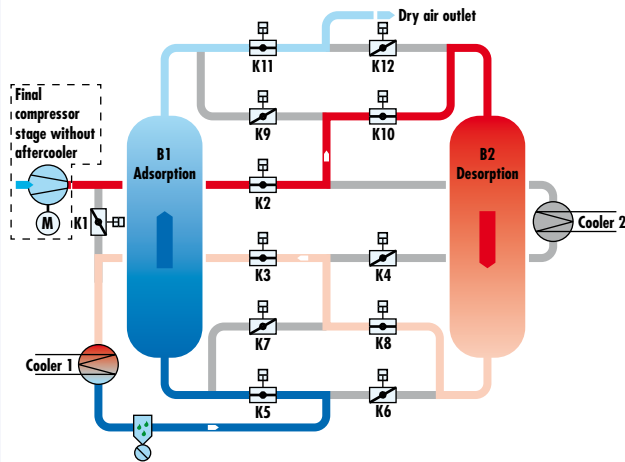

EVERDRY® HOC-P
Regeneration under partial flow



EVERDRY® HOC-F
Regeneration under full flow

**EVERDRY®: For flow rates from 580 – 20,000 m³/h (340 – 11,770 cfm).
Solutions for higher flow rates upon enquiry.**



... AND ON YOUR PRIORITIES

SELECTION CRITERION: LOCAL CLIMATE CONDITIONS

Climate zone		suitable series
Cold	■	FRP/FRA/FRL
Temperate	■	FRP/FRA/FRL
Subtropical	■	FRP/FRL
Tropical	■	FRP/FRL



SELECTION CRITERION: INVESTMENT AND OPERATING COSTS

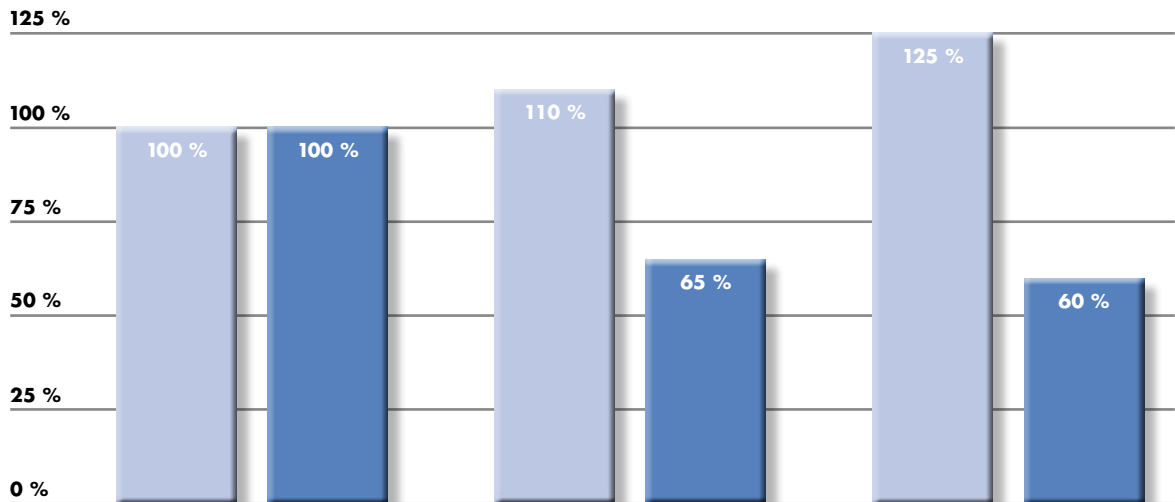

FRP
Suitable for universal application

FRA
ZERO PURGE cooling with ambient air cuts operating costs.

FRL
Closed cooling air circuit (LOOP) for critical ambient conditions cuts operating costs.

For the decision which series to choose it is important to consider not only the type of application but also the investment and operating costs as well as the particular payback period.

■ Investment costs ■ Operating costs

BEKO

HIGH QUALITY COMPRESSED AIR SUPPLY

BEKOMAT®

The convincing concept for condensate discharge

ÖWAMAT®

Clean and safe oil/water separation

BEKOSPLIT®

Splitting plants for the reliable, economic and environmentally friendly treatment of oil-water emulsions

CLEARPOINT®

Flow-optimised, reliable filters and water separators for compressed air and industrial gases

DRYPOINT®

Refrigeration dryers, adsorption dryers, membrane dryers

EVERDRY®

Compressed air drying for large volume flows

BEKOKAT®

Catalytic compressed-air processing for reliable oil-free compressed air.

BEKOBLIZZ®

Optimised cooling processes using deep-cooled, dry compressed air

METPOINT®

For the monitoring, control and optimisation of the compressed-air system

BEKOFLOW®

Innovative, cost-reducing compressed air pipe system



BEKO TECHNOLOGIES GMBH

Im Taubental 7
41468 Neuss
www.beko.de

Telefon +49 2131 988-0
Telefax +49 2131 988-900
beko@beko.de



Subject to technical changes without prior notice; the information provided does not represent characteristics of state within the meaning of the German Civil Code (BGB).

® Registered Trademarks by BEKO TECHNOLOGIES GmbH, Neuss

XP ED 002 INT
Edition 2010-03