

Centrifugal Immersion Pumps



More than just pumps



About FLUX

FLUX pump technology – the right solution even for demanding fluids



More than just pumps

One brand. One promise.

The FLUX name has been synonymous with pump technology for more than 60 years. It was the invention of the electric drum pump that sparked it all off. In the meantime, of course, the technology has become more sophisticated. FLUX company innovations have markedly improved working routines for filling and transferring fluids.

It is often said that medium-sized companies are the engines of progress. We would be pleased if our family business were able to substantiate this claim.

When you choose FLUX you are making a good decision for the long term. With our products we want to assist you to save time and money and by the way – spare your nerves as well. We are therefore delighted when you discuss your requirements with us.

Warmly,

A handwritten signature in black ink, appearing to read "K. Hahn".

Klaus Hahn,
CEO FLUX-GERÄTE GMBH

Pumping, emptying, mixing, filling and metering – when liquids are set in motion the requirements are very diverse. In any case the process must run smoothly. This is what the FLUX brand name stands for. It is recognised across the globe as a byword for quality, for safety and for solutions which are able to fulfil every single demand on a long-term basis.

Smooth-running processes – FLUX not only guarantees this for liquids which are easy to pump but also when the pumping medium is viscous or doesn't flow at all, when it is aggressive or used in processes which are common in the hygiene sector or sectors where there is an explosion hazard. To ensure that the tasks are solved in the best possible way for the customer FLUX has a huge range of expertise to offer. In other words, a lot more than just pumps. From a technical point of view this means a comprehensive product range of pumps, motors, flow meters, accessories and a whole lot more. From a project point of view, "More than just pumps", means accompanying our customers from the first telephone call through to the end solution – and if required beyond that.

This is how FLUX keeps processes moving. Long-term. Simple, complex or custom-made inclusive design assignments: FLUX is prepared for any request and in particular for the fact that our customers need more than just pumps.



The worldwide first electrical drum pump

FLUX Centrifugal Immersion Pumps –

Quality that sets standards.



Manufactured at our main plant, these ranges of immersion pumps are the result of extensive product and process evaluation by our research and development department. They are a true FLUX product, from conception through to manufacture, assembly and testing. Their design philosophy, and the materials selected for their construction make them ideal for applications in the chemical industry, surface treatment, electroplating, printed circuit manufacturing, water treatment and wastewater treatment. FLUX centrifugal immersion pumps can be used whenever liquids have to be transferred or circulated. They are suitable for use with a wide variety of acids and alkalis as well as other chemicals, typically coolants, lubricants and non-flammable solvents.

With delivery rates of up to 74 m³/h and delivery heads of maximum 35 m water column, FLUX centrifugal immersion pumps combine maximum efficiency with a robust and reliable construction, resulting in a pump that provides the ultimate in process security. These are features that you can rely on, each hour, 24 hours a day.

The mechanical seal types F 620 and F 640 are designed for typical liquid transfer operations, with either stationary or portable variants. These units compliment the well-proven barrel pumps range and have a higher output and kW-rating.

Top of the range, are the sealless units, these pumps complete the range of high output, high reliability immersion pumps. Designed for continuous use with a wide range of aggressive liquids, from acids to alkalis, the range includes the type F 706 – with only a sleeve bearing in contact with the liquid – or the types F 716 and F 726 - with a suspended free-flying shaft and no bearings or seals in contact with the liquid.

Three-phase drive motors are available as matched power units in kW-ratings from 0,37 to 5,5 kW, protected to IP 55 for models F 620, F 640, F 706 and F 726.

With immersion lengths from 300 to 4.000 mm almost every application requirement can be met. The use of high-class materials such as Hastelloy C and polyvinylidenfluoride, together with polypropylene and stainless steel, are combined with design experience perfected over decades of pump manufacturing. This guarantees the long service life of FLUX centrifugal immersion pumps.

Detailed information and performance charts are shown on the following pages.

To receive a quotation compiled to your application, please fill in the questionnaire on page 43 and return it to us.



Save, powerful, reliable – The new FLUX range

With 4 different design formats within the vertical centrifugal immersion pump range FLUX offer a cost effective, reliable solution for many liquid transfer and circulating operations. With these pumps FLUX meet the requirements of the market with their forward-looking designs and the manufacture of high quality products.

Type F 620 and F 640:

with mechanical seal in vertical and horizontal version

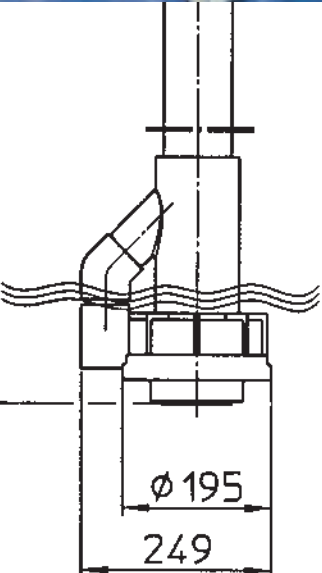

Type F 706:

4 different sizes, sealless design with sleeve bearing, immersion length up to 2.000 mm

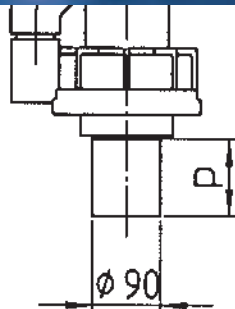

Type F 716:

compact design requires little space for installation, version with support tube or support bars for continuous use, suitable for dry operation

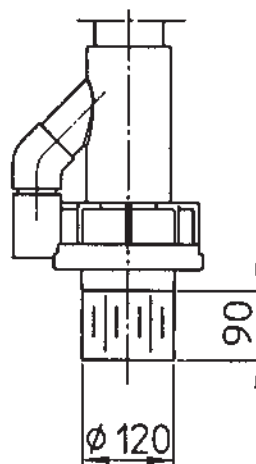

Type F 726:

very robust construction with shaft bearing located in a pedestal, version with support bars for continuous use, suitable for dry operation

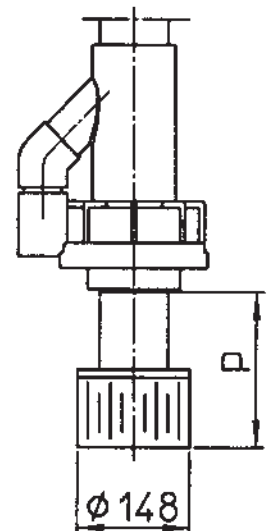

Introduction	2-5
Table of contents	
FLUX Centrifugal Immersion Pumps F 620 S size 15 and 30 in stainless steel for delivery rates of up to 23 m ³ /h	6-9
FLUX Centrifugal Immersion Pumps F 640 PP size 15, 30, 15 Z and 30 Z in polypropylene for delivery rates of up to 34 m ³ /h	10-13
FLUX Centrifugal Immersion Pumps F 640 PP and F 640 PVDF size 185 and 230 in polypropylene or polyvinylidenfluoride for delivery rates of up to 42 m ³ /h	14-17
FLUX Centrifugal Immersion Pumps F 620 S TR and F 640 PP TR for dry installation for horizontal use for delivery rates of up to 44 m ³ /h	18-21
FLUX Centrifugal Immersion Pumps F 706 PP size 135, 185, 230 and 350 in polypropylene for delivery rates of up to 74 m ³ /h	22-25
FLUX Centrifugal Immersion Pumps F 716 PP and F 716 PVDF size 115 and 135 in polypropylene or polyvinylidenfluoride for delivery rates of up to 12 m ³ /h	26-29
FLUX Centrifugal Immersion Pumps F 716 PP and F 716 PVDF size 185 and 230 in polypropylene or polyvinylidenfluoride for delivery rates of up to 45 m ³ /h	30-33
FLUX Centrifugal Immersion Pumps F 726 PP and F 726 PVDF size 115 and 135 in polypropylene or polyvinylidenfluoride for delivery rates of up to 12 m ³ /h	34-37
FLUX Centrifugal Immersion Pumps F 726 PP and F 726 PVDF size 185 and 230 in polypropylene or polyvinylidenfluoride for delivery rates of up to 45 m ³ /h	38-41
Dimensions of three-phase motors	42-43
Questionnaire	

FLUX Centrifugal Immersion Pump F 620 S in stainless steel

Size 15 and 30

Typical Applications

Transferring low flammability liquids up to a viscosity of 2.500 mPas (cP) from containers or tanks, either open topped or closed. Suitable for stationary or portable applications.

Construction features

Centrifugal pump in stainless steel consisting of an inner tube and outer tube.

The centrifugal impeller in the pump housing is driven by the motor via the drive shaft. The drive shaft is supported by intermediate bearings within the inner tube, a mechanical seal separates the liquid from the bearings and upper shaft. This construction provides the ultimate in stability, and ensures the maximum integrity of the mechanical seal. With an open conical impeller.

Three-phase motors in differing kW-ratings are available as a matched power unit. Connection to the pump is made via a flexible coupling.



F 620 S-30
with suction
strainer

Construction features in detail

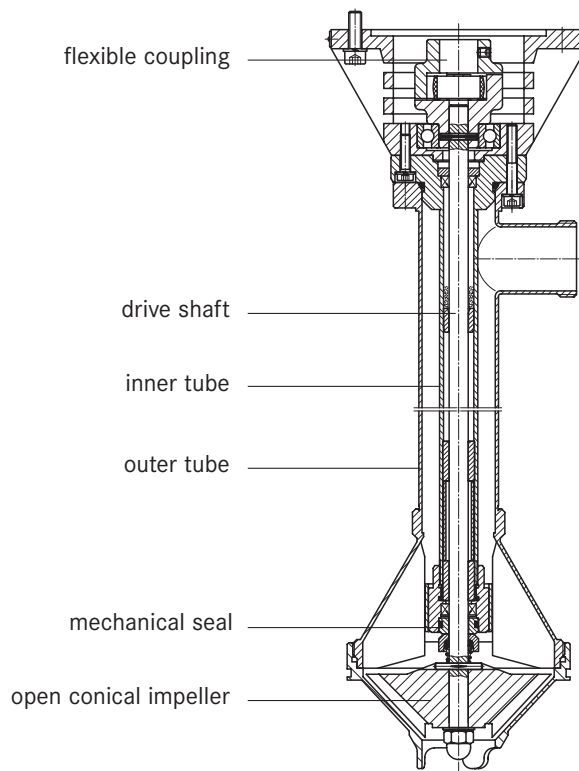

Centrifugal Immersion Pump F 620 S in stainless steel,

thread on outlet G 1½ A, without drive motor

Type/Size	F 620 S-15	F 620 S-30
Delivery rate Q max.	19 m³/h	23 m³/h
Delivery head H max.	10 m water column	12 m water column
Viscosity max.	2.500 mPas	2.500 mPas
Temperature max.	100 °C	100 °C
Seal type	mechanical seal in ceramic oxide, o-rings in FKM	
Material	shaft in stainless steel 316 Ti, seal in FKM	
Impeller	conical impeller in polypropylene (version in stainless steel on request)	
Pump housing	Ø 140 mm	Ø 140 mm
Part No.		
Immersion length Dimension e 700 mm	10-620 23 001	10-621 23 001
Immersion length Dimension e 1000 mm	10-620 23 002	10-621 23 002
Immersion length Dimension e 1500 mm	10-620 23 003	10-621 23 003

Part numbers for immersion length 300 to 3.000 mm (in steps of 100 mm) on request.

Accessories	Part No.
Mounting flange in stainless steel 316 Ti outside Ø 265 mm, pitch circle Ø 225 mm, 8 bores Ø 18 mm each	10-947 14 005
Suction strainer in stainless steel 316 Ti	10-001 10 232
Hose connection in stainless steel, complete with nut in brass G 1½	
for hose inside diameter DN 25	10-959 04 002
for hose inside diameter DN 32	10-959 04 003
for hose inside diameter DN 38	10-959 04 004

Drive motors for Centrifugal Immersion Pump F 620 S,

three-phase motors protected to IP 55, with motor protection switch or cable terminal box

Capacity	Voltage	Frequency	Nominal speed	Part No.	Part No.
P2				Version with motor protection switch	Version with cable terminal box
0,75 kW	230/400 V	50 Hz	3.000 rpm	10-001 03 379	10-001 03 378
1,1 kW	230/400 V	50 Hz	3.000 rpm	10-001 03 381	10-001 03 380
1,5 kW	230/400 V	50 Hz	3.000 rpm	10-001 03 383	10-001 03 382
2,2 kW	230/400 V	50 Hz	3.000 rpm	10-001 03 385	10-001 03 384
3,0 kW	400 V	50 Hz	3.000 rpm	10-001 03 387	10-001 03 386
4,0 kW	400 V	50 Hz	3.000 rpm	10-001 03 389	10-001 03 388

Accessories	Part No.
Carrying handle for three-phase motors up to 3,0 kW	10-001 10 571
Carrying handle for three-phase motors up 4,0 kW	10-001 10 531
Carrying handle for three-phase motors explosion-proof up to 3,3 kW	10-001 10 586

Scope of supply

A complete vertical centrifugal immersion pump consists of: drive motor, pump and necessary accessories.

Weight per pump: 15 – 45 kg depending on the pump size, immersion length and motor kW.

FLUX Centrifugal Immersion Pump F 620 S in stainless steel

Size 15 and 30

Technical data

Performance chart FLUX F 620 S-15 and F 620 S-30

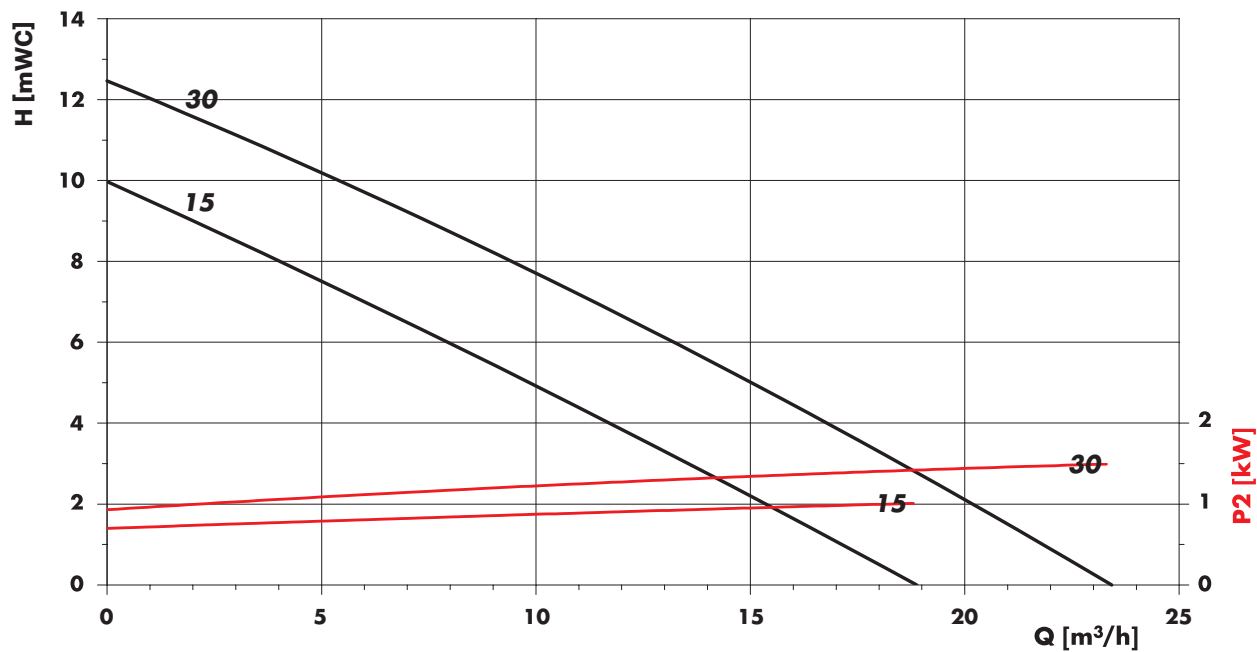

Measured values $\pm 10\%$ determined with water (20 °C). Nominal speed $n = 2.850$ rpm

In determining the absorbed kW of the motor, multiply the absorbed kW shown in the above diagram with the specific gravity of the liquid to be pumped.

Technical data
Dimensions F 620 S-15 and F 620 S-30

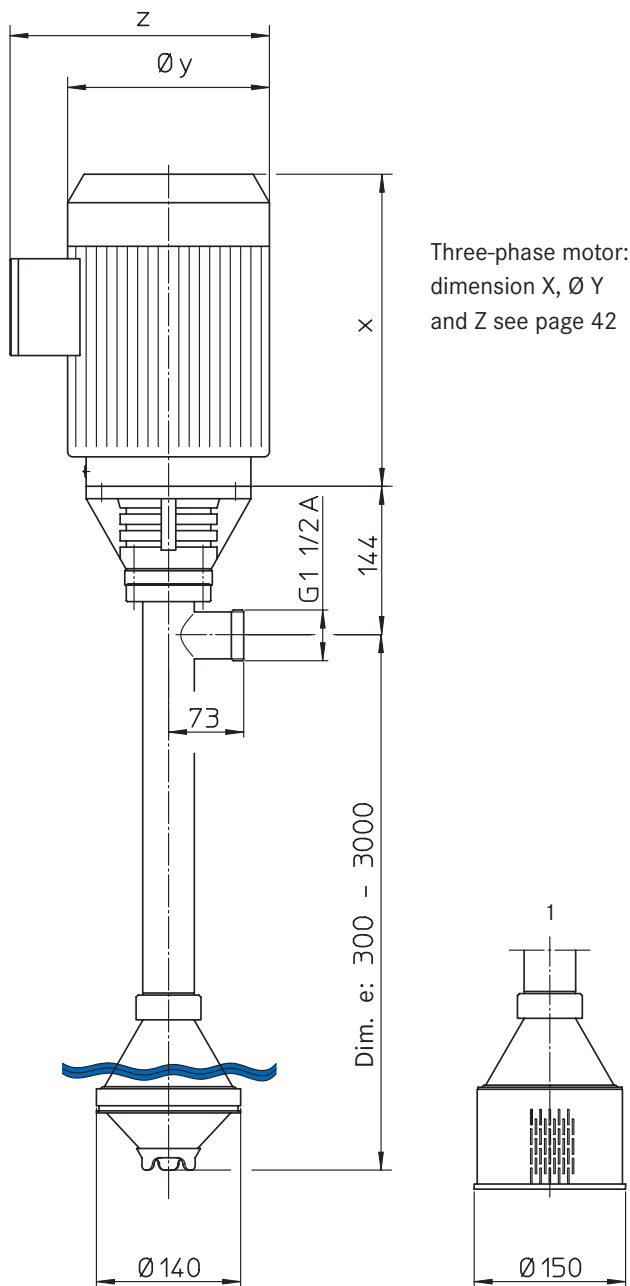

Minimum liquid level
 when starting the pump.
 Also valid for variant 1.

Variant 1
 with suction strainer
 dimension $e + 28$ mm

Basic model
 dimension e max. 3.000 mm

FLUX Centrifugal Immersion Pump F 640 PP in polypropylene

Size 15, 30, 15 Z and 30 Z

Typical Applications

Transferring low flammability liquids up to a viscosity of 2.500 mPas (cP) from containers, tanks, either open topped or closed.

Transferring corrosive liquids in chemical processing and engineering, metal-working and electroplating together with water treatment and waste water treatment. Suitable for stationary or portable application.

Construction features

Vertical centrifugal immersion pump in polypropylene consisting of an inner tube and outer tube.

The centrifugal impeller in the pump housing is driven by the motor via the drive shaft. The drive shaft is supported by intermediate bearings within the plastic sleeved steel inner tube, a mechanical seal separating the liquid from the bearings and upper shaft. This construction provides the ultimate in stability, preventing elongation of the plastic at high temperatures and ensures the maximum integrity of the mechanical seal. With an open conical impeller or a closed centrifugal impeller (Z). The liquid is delivered between the inner and outer tubes to the pump outlet.

Three-phase motors in differing kW-ratings are available as a matched power unit. Connection to the pump is made via a flexible coupling.



F 640 PP-30
with suction
strainer

Construction features in detail

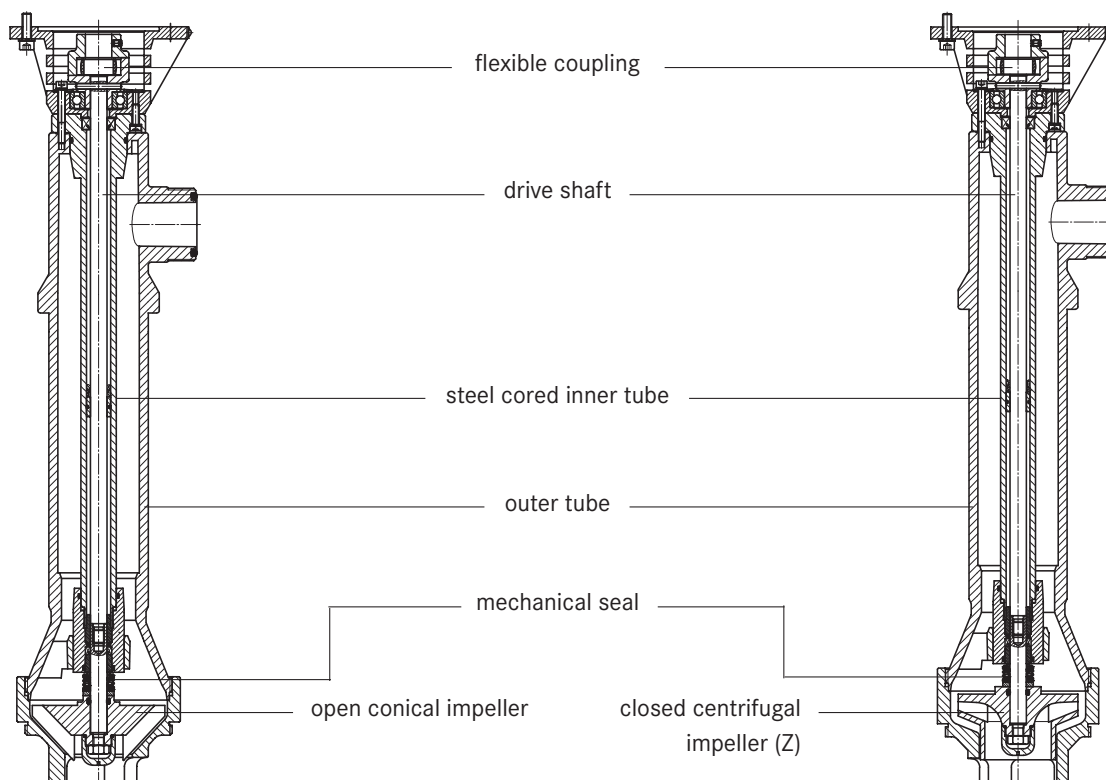

Centrifugal Immersion Pump F 640 PP in polypropylene,

thread on outlet G 2¼ A, without drive motor

Type/Size	F 640 PP-15	F 640 PP-30	F 640 PP-15 Z	F 640 PP-30 Z
Delivery rate Q max.	17 m³/h	29 m³/h	21 m³/h	34 m³/h
Delivery head H max.	8 m water column	10 m water column	10 m water column	11 m water column
Viscosity max.	2.500 mPas	2.500 mPas	150 mPas	150 mPas
Temperature max.	50 °C	50 °C	50 °C	50 °C
Seal type	mechanical seal in ceramic oxide / SiC, o-rings in FKM			
Material	shaft in Hastelloy C, seals in FKM			
Impeller	open conical impeller in PP		closed centrifugal impeller in PP	
Pump housing	Ø 148 mm	Ø 148 mm	Ø 148 mm	Ø 148 mm
Part No.				
Immersion length Dimension e 700 mm	10-640 41 407	10-640 41 607	10-640 41 507	10-640 41 707
Immersion length Dimension e 1.000 mm	10-640 41 410	10-640 41 610	10-640 41 510	10-640 41 710
Immersion length Dimension e 1.500 mm	10-640 41 415	10-640 41 615	10-640 41 515	10-640 41 715

Part numbers for immersion length 400 to 4.000 mm (in steps of 100 mm) on request.

Accessories	Part No.
Suction strainer in polypropylene outside Ø 265 mm, pitch circle Ø 225 mm, 8 bores Ø 18 mm	10-947 14 001
Hose connection in polypropylene, complete with nut G 2¼ for hose inside diameter DN 32	10-959 04 098
for hose inside diameter DN 38	10-959 04 099
for hose inside diameter DN 50	10-959 04 100

Drive motors for Centrifugal Immersion Pump F 640 PP,

three-phase motors protected to IP 55, with motor protection switch or cable terminal box

Capacity	Voltage	Frequency	Nominal speed	Part No.	Part No.
P2				Version with motor protection switch	Version with cable terminal box
0,75 kW	230/400 V	50 Hz	3.000 rpm	10-001 03 379	10-001 03 378
1,1 kW	230/400 V	50 Hz	3.000 rpm	10-001 03 381	10-001 03 380
1,5 kW	230/400 V	50 Hz	3.000 rpm	10-001 03 383	10-001 03 382
2,2 kW	230/400 V	50 Hz	3.000 rpm	10-001 03 385	10-001 03 384
3,0 kW	400 V	50 Hz	3.000 rpm	10-001 03 387	10-001 03 386
4,0 kW	400 V	50 Hz	3.000 rpm	10-001 03 389	10-001 03 388

Accessories	Part No.
Carrying handle for three-phase motors up to 3,0 kW	10-001 10 571
Carrying handle for three-phase motors up 4,0 kW	10-001 10 531
Carrying handle for three-phase motors explosion-proof up to 3,3 kW	10-001 10 586

Scope of supply

A complete vertical centrifugal immersion pump consists of: drive motor, pump and necessary accessories.

Weight per pump: 15 – 60 kg depending on the pump size, immersion length and motor kW.

FLUX Centrifugal Immersion Pump F 640 PP in polypropylene

Size 15, 30, 15 Z and 30 Z

Technical data

Performance chart F 640 PP-15, F 640 PP-30, F 640 PP-15 Z and F 640 PP-30 Z

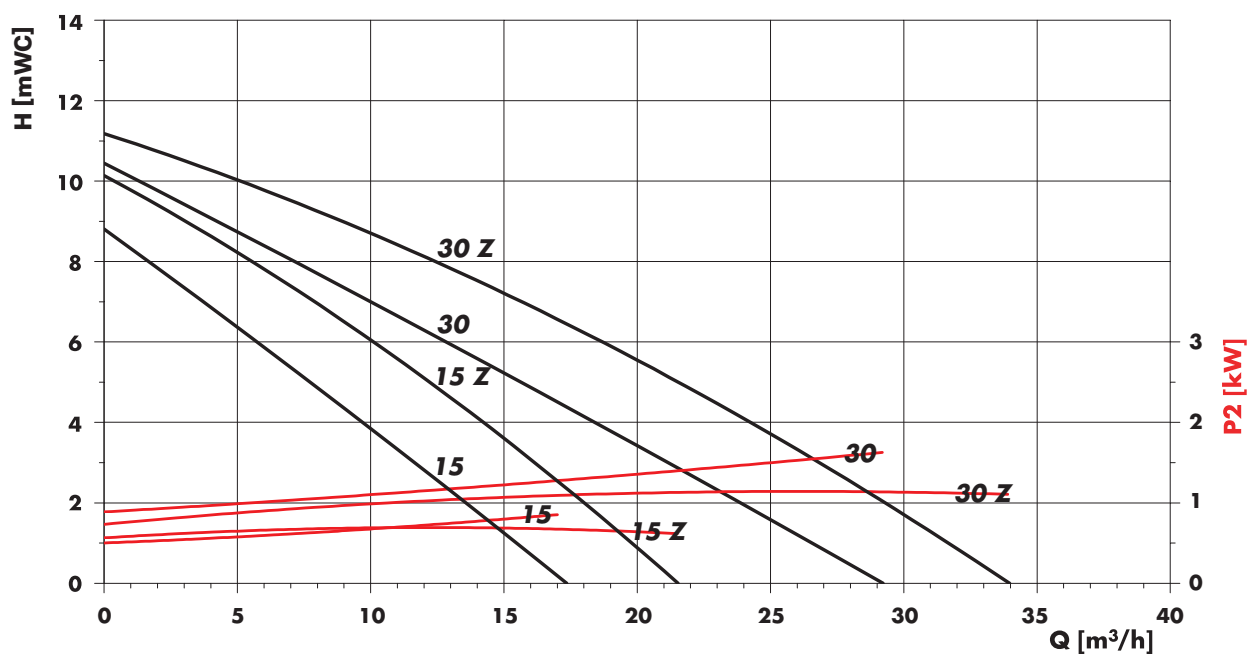

Measured values $\pm 10\%$ determined with water (20 °C). Nominal speed $n = 2.850$ rpm

In determining the absorbed kW of the motor, multiply the absorbed kW shown in the above diagram with the specific gravity of the liquid to be pumped.

Technical data

Dimensions F 640 PP-15, F 640 PP-30, F 640 PP-15 Z and F 640 PP-30 Z

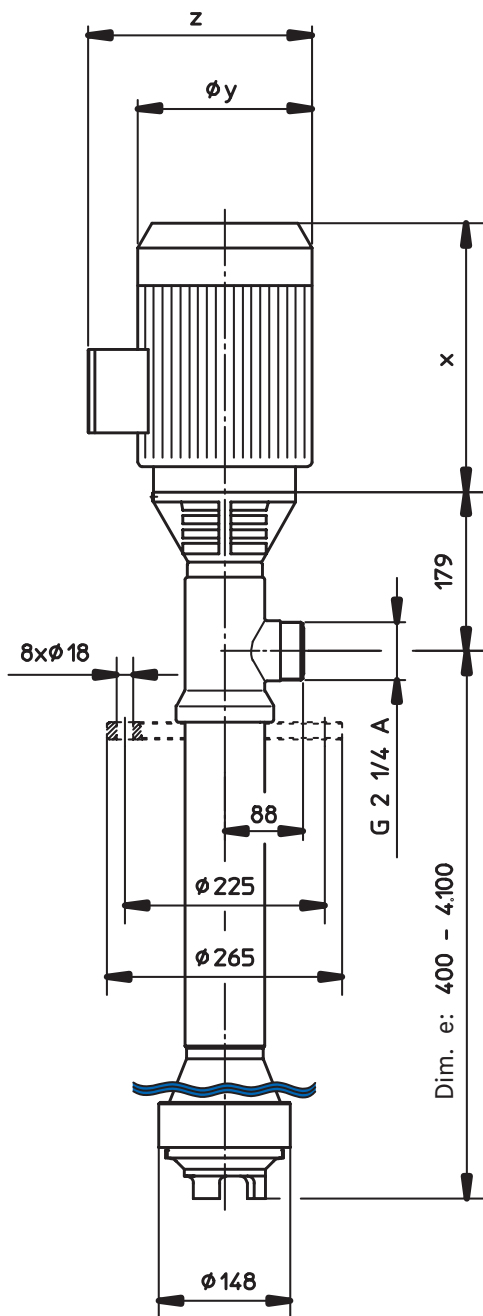

Three-phase motor:
dimension X, ϕY
and Z see page 42

Minimum liquid level
when starting the pump.
Also valid for variant 1.

Variant 1
with suction strainer
dimension e + 38 mm

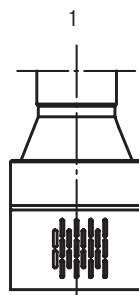

Basic model
dimension e max. 4.100 mm

FLUX Centrifugal Immersion Pump F 640 PP and F 640 PVDF

Size 185 and 230

Typical applications

Transferring low flammability liquids up to a viscosity of 2.500 mPas (cP) from containers, tanks, either open topped or closed. Transferring corrosive liquids in chemical processing and engineering, metal-working and electroplating together with water treatment and waste water treatment. Suitable for stationary or portable application.

Construction features

Vertical centrifugal immersion pump for stationary application. The centrifugal impeller in the pump housing is driven by the motor via the drive shaft. The drive shaft is supported by intermediate bearings within the plastic sleeved steel inner tube, a mechanical seal separating the liquid from the bearings and upper shaft. This construction provides the ultimate in stability, preventing elongation of the plastic at high temperatures and ensures the maximum integrity of the mechanical seal.

This pump design does not have a separate discharge tube. Immediately after the pump housing the liquid is fed back into the outer tube and delivered to the outlet connection between the inner and outer tubes.

A range of carefully chosen impeller diameters, together with a range of three-phase motors in differing kW-ratings, ensures the optimum selection of pumps to meet the specific operating requirements. Connection of pump and motor is made via a flexible coupling.



F 640 PP-185
with mounting flange

Construction features in detail

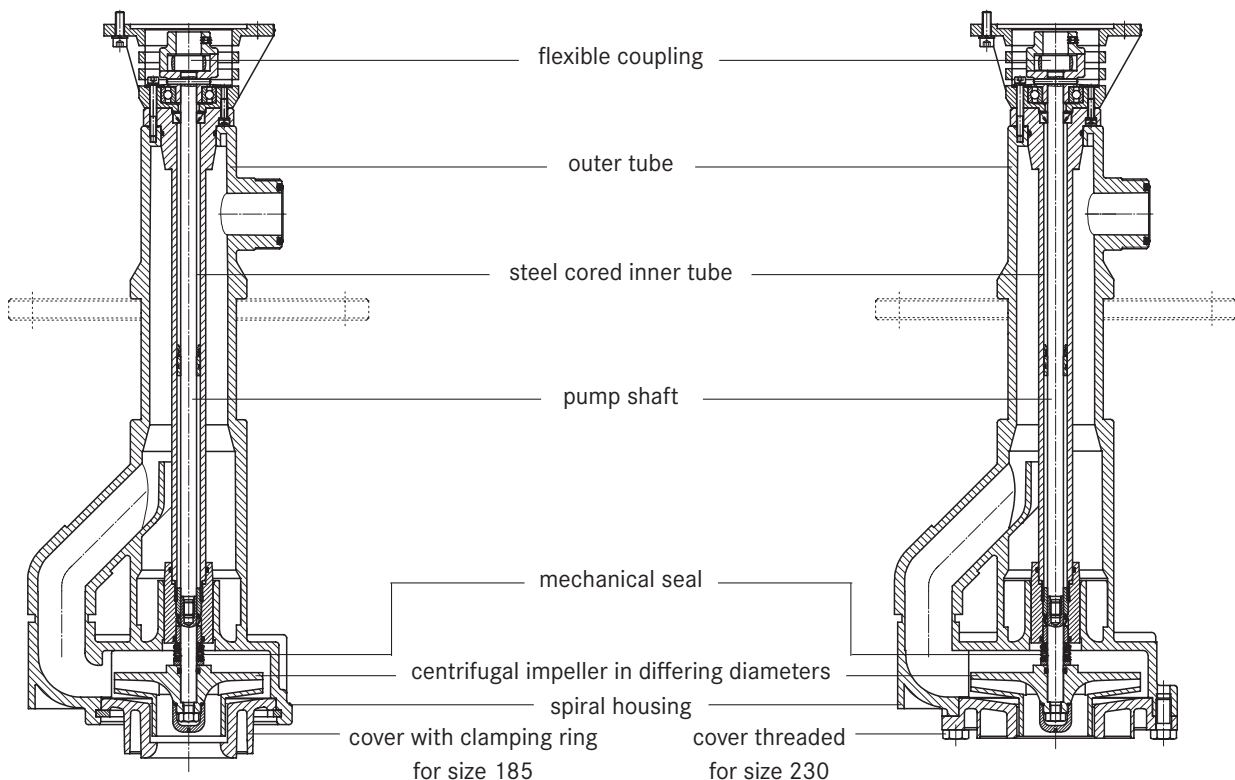

Centrifugal Immersion Pump F 640 PP in polypropylene and F 640 PVDF in polyvinylidenfluoride,

thread on outlet G 2¼ A, without drive motor

Type/Size	F 640 PP-185	F 640 PVDF-185	F 640 PP-230	F 640 PVDF-230
Delivery rate Q max.	40 m³/h	40 m³/h	42 m³/h	42 m³/h
Delivery head H max.	23 m water column	23 m water column	32 m water column	32 m water column
Viscosity max.	150 mPas	150 mPas	150 mPas	150 mPas
Temperature max.	60 °C	80 °C	60 °C	80 °C
Seal type	mechanical seal in ceramic oxide /SiC, o-rings in FKM			
Material	shaft in Hastelloy C, seals in FKM			
Impeller	Ø 100 – 140 mm in PP or PVDF		Ø 130 – 160 mm in PP or PVDF	
Pump housing	Ø 249 mm		Ø 264 mm	
Part No.				
Immersion length Dimension e 1.000 mm	10-640 41 210	10-640 61 210	10-640 41 310	10-640 61 310
Immersion length Dimension e 1.500 mm	10-640 41 215	10-640 61 215	10-640 41 315	10-640 61 315
Immersion length Dimension e 2.000 mm	10-640 41 220	10-640 61 220	10-640 41 320	10-640 61 320

Part numbers for immersion length 400 to 4.100 mm (in steps of 100 mm) on request.
From dimension 2.100 mm with welded pump housing part number 10-640 42 ... or rather 10-640 62 ...

Accessories	Part No.
Mounting flange in polypropylene to dimension 2.000 mm: outside Ø 340 mm, pitch circle Ø 295 mm, 4 bores Ø 22 mm from dimension 2.100 mm: outside Ø 445 mm, pitch circle Ø 400 mm, 4 bores Ø 22 mm	10-947 14 049 10-947 14 084
Mounting flange in polyvinylidenfluoride to dimension 2.000 mm: outside Ø 340 mm, pitch circle Ø 295 mm, 4 bores Ø 22 mm from dimension 2.100 mm: outside Ø 445 mm, pitch circle Ø 400 mm, 4 bores Ø 22 mm	10-947 14 070 10-947 14 085
Suction strainer in PP or PVDF welded onto the cover of the pump housing	
Hose connection in polypropylene, complete with nut G 2¼	
for hose inside diameter DN 32	10-959 04 098
for hose inside diameter DN 38	10-959 04 099
for hose inside diameter DN 50	10-959 04 100
Hose connection in polyvinylidenfluoride, complete with nut	
for hose inside diameter DN 32	10-959 04 104
for hose inside diameter DN 38	10-959 04 105
for hose inside diameter DN 50	10-959 04 096

Drive motors for Centrifugal Immersion Pump F 640 PP and F 640 PVDF,

three-phase motors protected to IP 55, with motor protection switch or cable terminal box

Capacity	Voltage	Frequency	Nominal speed	Part No.	Part No.
P2				Version with motor protection switch	Version with cable terminal box
0,75 kW	230/400 V	50 Hz	3.000 rpm	10-001 03 379	10-001 03 378
1,1 kW	230/400 V	50 Hz	3.000 rpm	10-001 03 381	10-001 03 380
1,5 kW	230/400 V	50 Hz	3.000 rpm	10-001 03 383	10-001 03 382
2,2 kW	230/400 V	50 Hz	3.000 rpm	10-001 03 385	10-001 03 384
3,0 kW	400 V	50 Hz	3.000 rpm	10-001 03 387	10-001 03 386
4,0 kW	400 V	50 Hz	3.000 rpm	10-001 03 389	10-001 03 388

Scope of supply

A complete vertical centrifugal immersion pump consists of: drive motor, pump with mounting flange and necessary accessories.
Weight per pump: 20 – 70 kg depending on the pump size, immersion length and motor kW.

FLUX Centrifugal Immersion Pump F 640 PP and F 640 PVDF

Size 185 and 230

Technical data

Performance chart F 640 PP-185 and F 640 PVDF-185

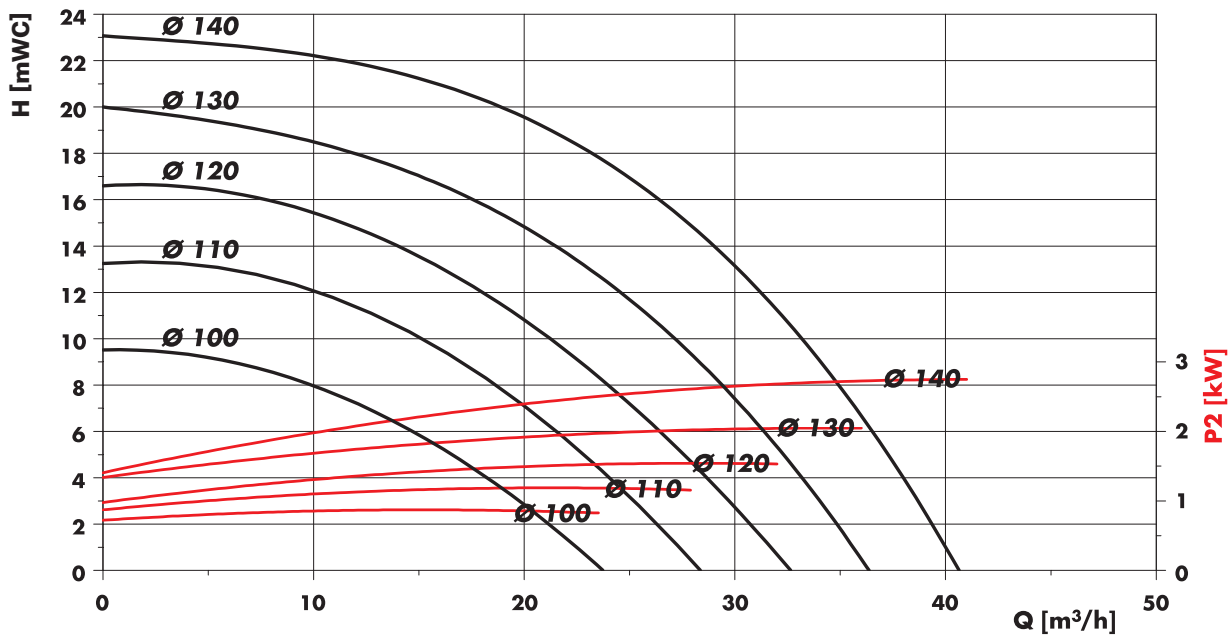

Measured values $\pm 10\%$ determined with water (20 °C). Nominal speed $n = 2.850$ rpm

In order to achieve the desired output, centrifugal impellers in diameters of 100 to 160 mm are available.

In determining the absorbed kW of the motor, multiply the absorbed kW shown in the above diagram with the specific gravity of the liquid to be pumped.

Performance chart F 640 PP-230 and F 640 PVDF-230

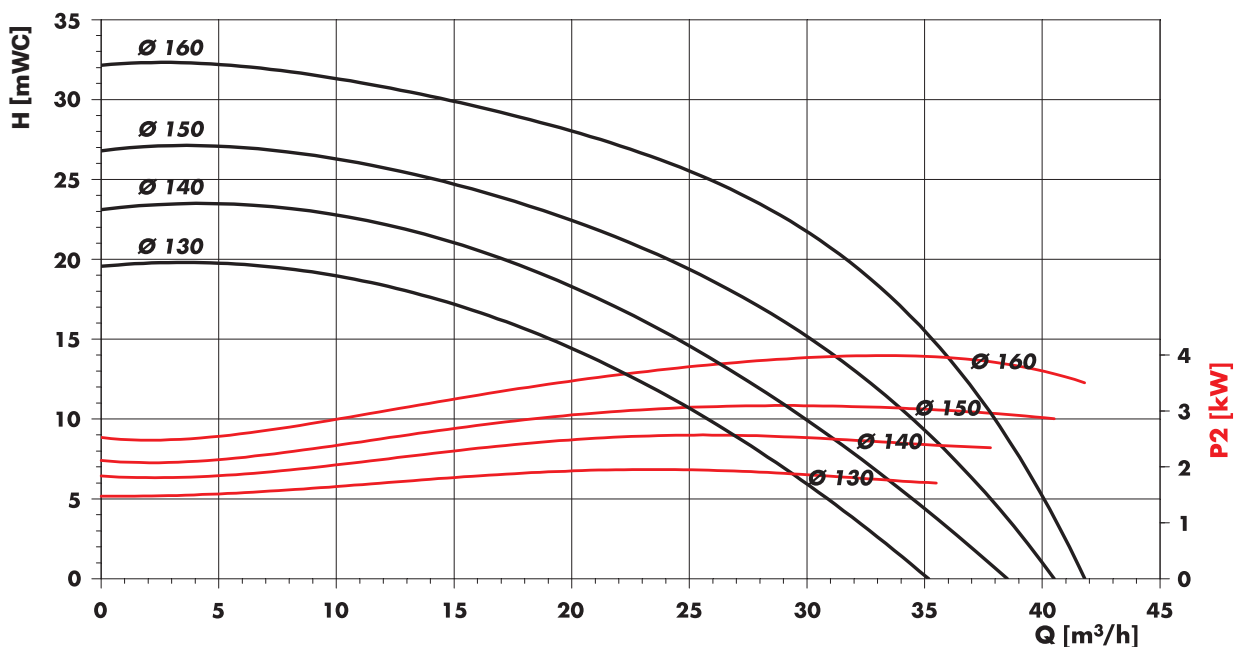

Technical data

Dimensions F 640 PP-185 and F 640 PVDF-185

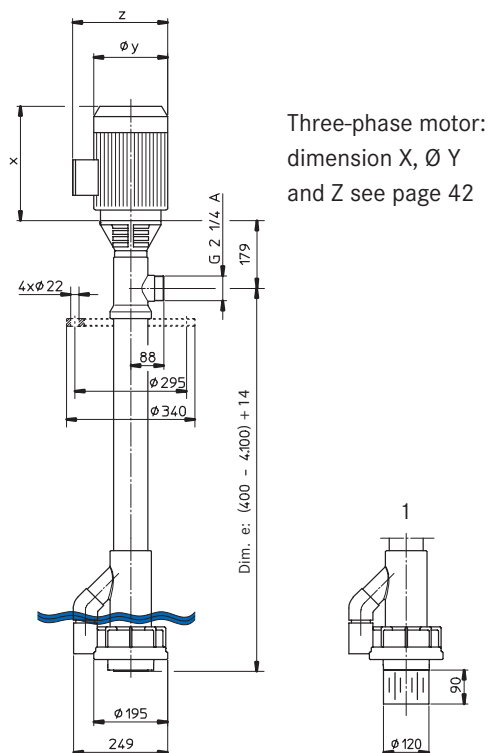

Three-phase motor:
dimension X, Ø Y
and Z see page 42

Minimum liquid level
when starting the pump.
Also valid for variant 1.

Variant 1
with suction strainer
dimension e + 90 mm

Basic model dimension e
max. 4.100 mm

Dimensions F 640 PP-230 and F 640 PVDF-230

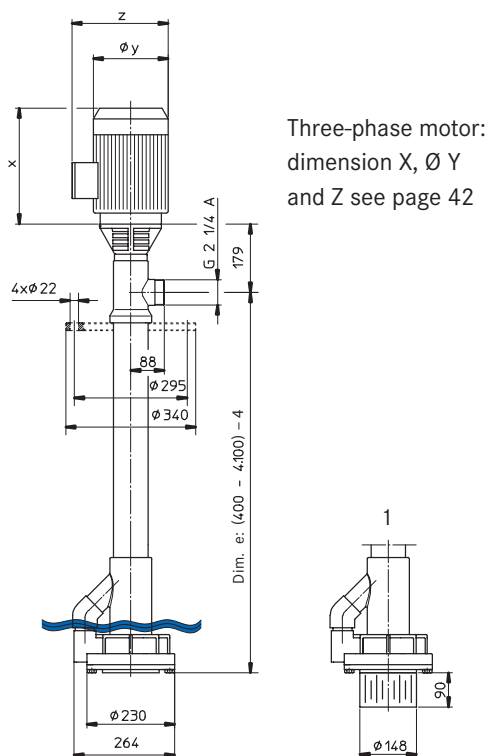

Three-phase motor:
dimension X, Ø Y
and Z see page 42

Minimum liquid level
when starting the pump.
Also valid for variant 1.

Variant 1
with suction strainer
dimension e + 90 mm

Basic model dimension e
max. 4.100 mm

FLUX Centrifugal Immersion Pump F 620 S TR and F 640 PP TR

for dry installation for horizontal use

Typical applications

Transferring low flammability liquids up to a viscosity of 2.500 mPas (cP) from containers or tanks, either open topped or closed. The pump is used either horizontally mounted onto a base plate or fixed vertically.

Construction features

Centrifugal pump in horizontal version in stainless steel or polypropylene, consisting of an inner tube and outer tube.

The centrifugal impeller in the pump housing is driven by the motor via the drive shaft. The drive shaft is supported by intermediate bearings within inner tube, a mechanical seal separates the liquid from the bearings and upper shaft. The PP version has a steel cored PP inner tube. This construction provides the ultimate in stability, preventing elongation of the plastic at high temperatures and ensures the maximum integrity of the mechanical seal.

With an open conical impeller or a closed centrifugal impeller (Z)

Depending on the model, suction and discharge sides are fitted with threaded or flanged connections.

Three-phase motors in differing kW-ratings are available as a matched power unit. Connection to the pump is made via a flexible coupling.

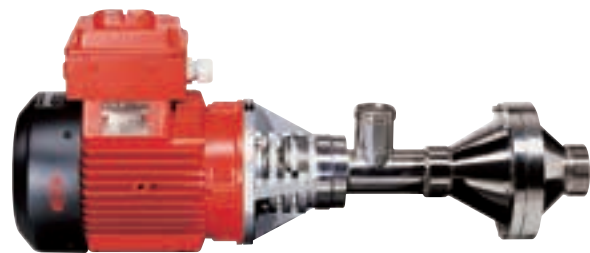

F 620 S-30 TR



F 640 PP-30 TR

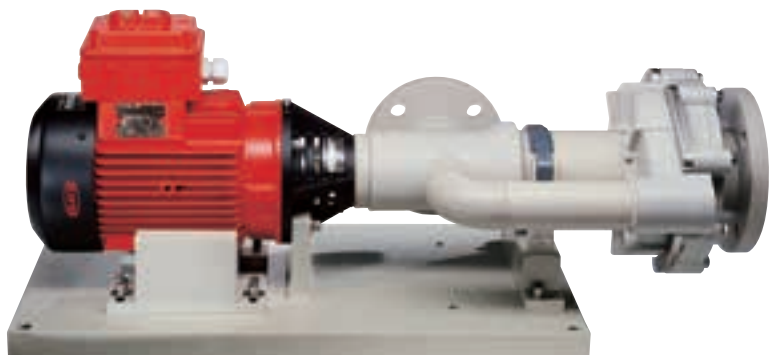

F 640 PP-230 TR with base plate

Centrifugal Immersion Pump F 620 S TR in stainless steel,

without drive motor

Type/Size	F 620 S-30 TR
Delivery rate Q max.	23 m ³ /h
Delivery head H max.	12 m water column
Viscosity max.	2.500 mPas
Temperature max.	100 °C
Seal type	mechanical seal in ceramic oxide, o-rings in FKM
Material	shaft in stainless steel 316 Ti, seals in FKM
Impeller	open conical impeller in polypropylene (version in stainless steel on request)
Suction side	thread G 2 A
Discharge side	thread G 1½ A
Part No.	10-620 25 502

Accessoires	Part No.
Base plate in polypropylene	10-001 15 024
Hose connection in stainless steel, complete with nut G 1½ for hose inside diameter DN 25	10-959 04 002
for hose inside diameter DN 32	10-959 04 003
for hose inside diameter DN 38	10-959 04 004

Centrifugal Immersion Pump F 640 PP TR in polypropylene,

without drive motor

Type/Size	F 640 PP-30 TR	
Delivery rate Q max.	29 m ³ /h	
Delivery head H max.	10 m water column	
Viscosity max.	2.500 mPas	
Temperature max.	50 °C	
Seal type	mechanical seal in ceramic oxide /SiC, o-rings in FKM	
Material	shaft in Hastelloy C, seals in FKM	
Impeller	open conical impeller in PP	
Suction side	thread G 2 A	flange DN 65, PN 10
Discharge side	thread G 2½ A	flange DN 50, PN 10
Part No.	10-640 41 601	10-640 41 600

Centrifugal Immersion Pump F 640 PP TR in polypropylene,

without drive motor

Type/Size	F 640 PP-230 TR
Delivery rate Q max.	44 m ³ /h
Delivery head H max.	33 m water column
Viscosity max.	150 mPas
Temperature max.	60 °C
Seal type	mechanical seal in ceramic oxide/SiC, o-rings in FKM
Material	shaft in Hastelloy C, seals in FKM
Impeller	Ø 100 - 160 mm in PP
Suction side	flange DN 65, PN 10; outside Ø 185 mm, p.c.Ø 145 mm, 4 bores Ø 18 mm each
Discharge side	flange DN 50, PN 10; outside Ø 165 mm, p.c.Ø 125 mm, 4 bores Ø 18 mm each
Part No.	10-640 41 300

Accessories	Part No.
Base plate in polypropylene for F 640 PP-30 TR and F 640 PP-230 TR	10-001 15 023
Hose connection in polypropylene, complete with nut G 2¼ for hose inside diameter DN 32	10-959 04 098
for hose inside diameter DN 38	10-959 04 099
for hose inside diameter DN 50	10-959 04 100

Drive motors see page 15.

Scope of supply

A complete centrifugal immersion pump for dry installation consists of drive motor, pump and base plate.

Weight per pump including base plate: 9 - 50 kg depending on pump size and motor kW.

FLUX Centrifugal Immersion Pump

F 620 S TR and F 640 PP TR

for dry installation for horizontal use

Technical data

Performance chart F 620 S-30 TR

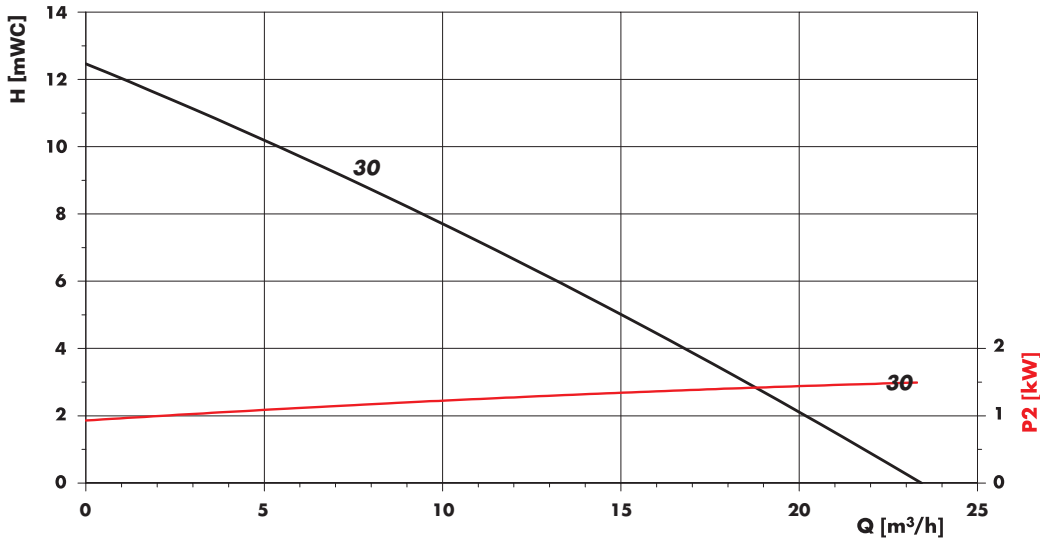

Performance chart F 640 PP-30 TR

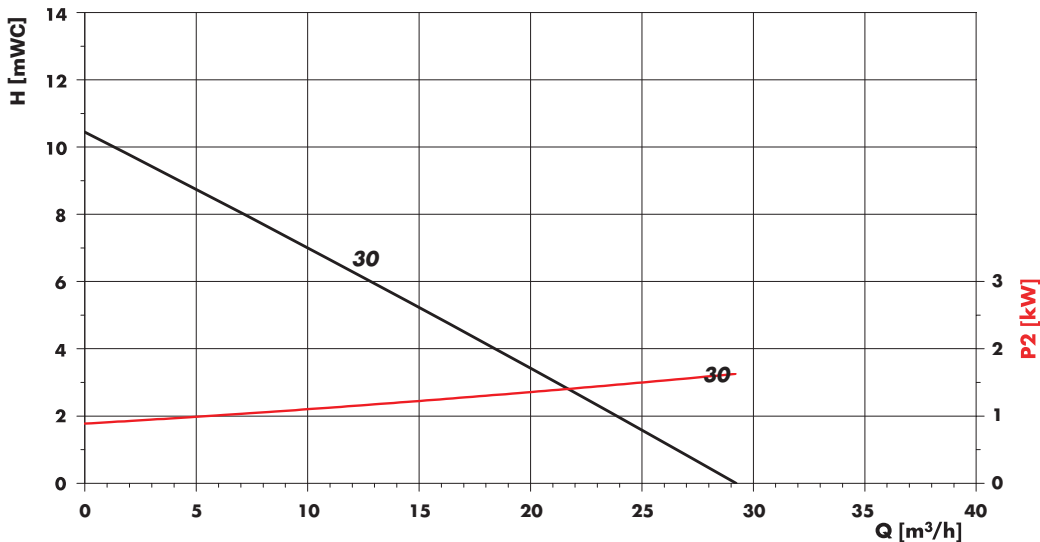

Performance chart F 640 PP-230 TR

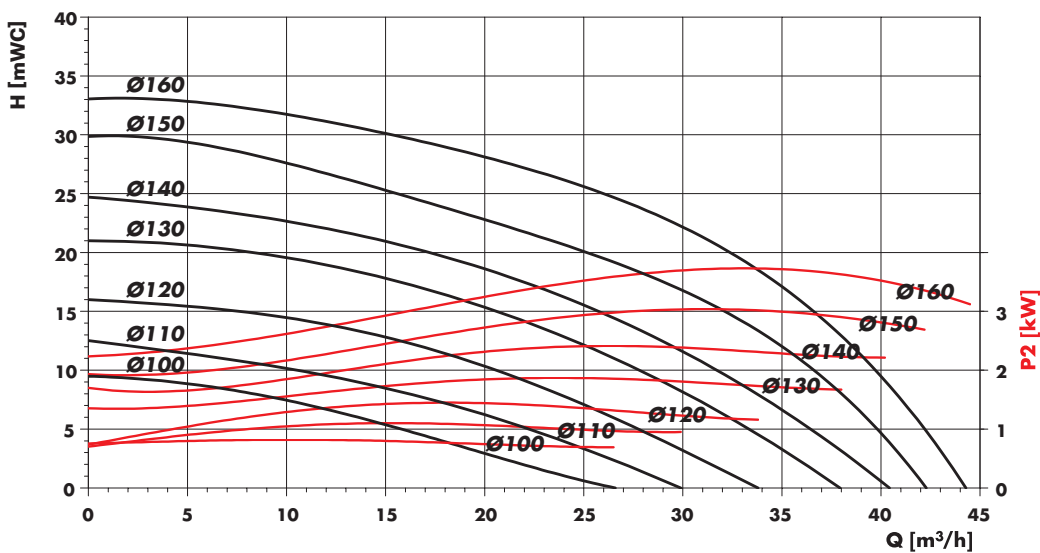

Measured values $\pm 10\%$ determined with water (20 °C). Nominal speed $n = 2.850$ rpm
 In determining the absorbed kW of the motor, multiply the absorbed kW shown in the above diagram with the specific gravity of the liquid to be pumped.

Technical data

Dimensions F 620 S-30 TR

Three-phase motor: dimension X, Ø Y and Z see page 42

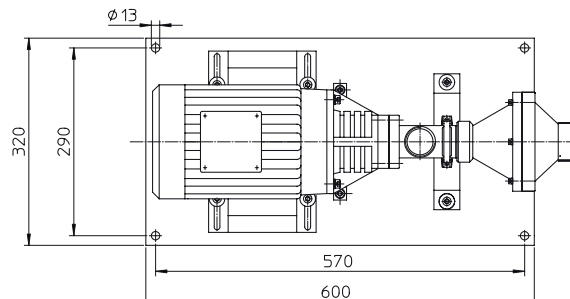
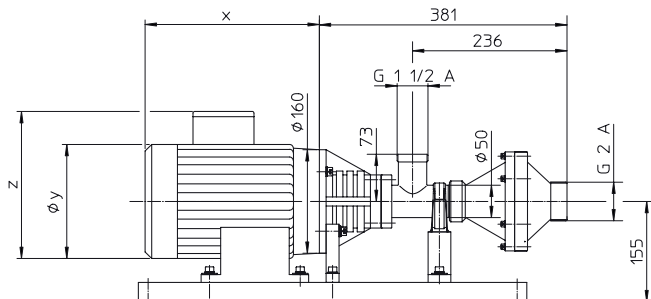

Dimensions F 640 PP-30 TR with thread connection

Three-phase motor: dimension X, Ø Y and Z see page 42

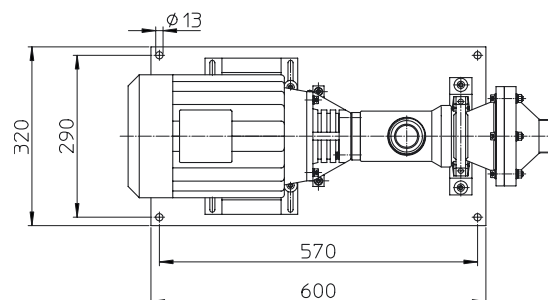
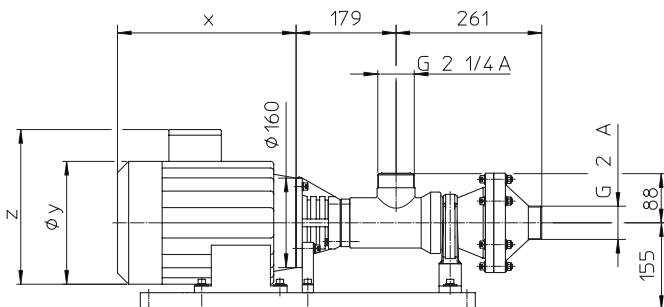

Dimensions F 640 PP-30 TR with flange connection

Three-phase motor: dimension X, Ø Y and Z see page 42

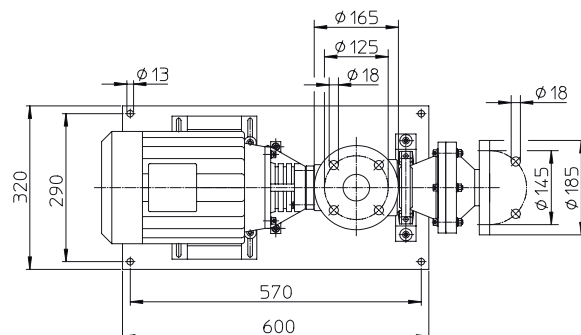
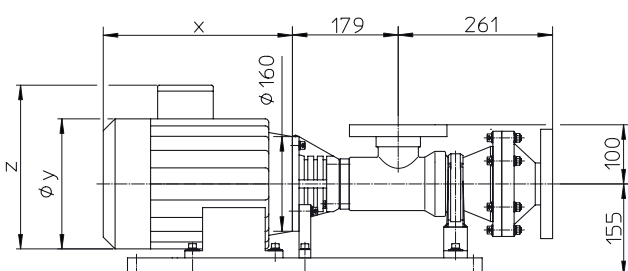

Dimensions F 640 PP-230 TR

Three-phase motor: dimension X, Ø Y and Z see page 42

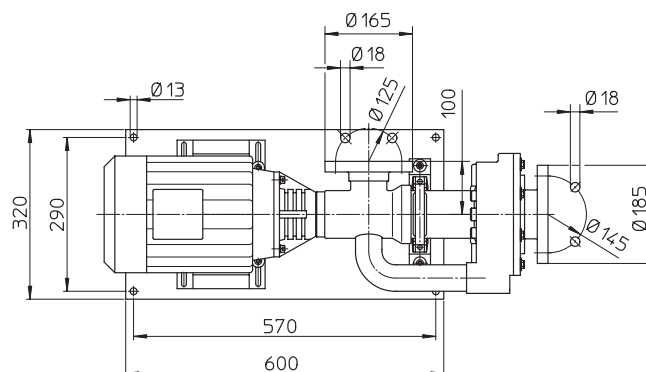
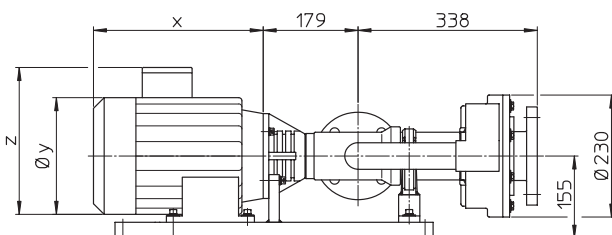

FLUX Centrifugal Immersion Pumps

F 706 PP in polypropylene

Size 135, 185, 230 and 350

Typical applications

Transfer of corrosive liquids in the chemical industry and all aspects of chemical engineering together with any application that requires the safe and economical transfer, or circulation, of acids and alkalis or other chemical fluids, with or without solids in suspension.

Construction features

Vertical centrifugal immersion pump for stationary application. The robust pump housing is solidly welded to the support tube. A sleeve bearing, which is lubricated by the liquid, allows immersion lengths of up to 1.000 mm, and on the pump size 230, with additional intermediate bearings, even up to 2.000 mm.

A large polpypropylene-coated drive shaft together with the use of a thick-walled support tube ensures a very smooth running pump. This type of construction prevents the rotating components from coming to contact with the pump housing and guarantees a long service life and extended maintenance intervals, even in the case of continuous use.

A range of carefully chosen impeller diameters, together with a range of three-phase motors in differing kW-ratings, ensures the optimum selection of pumps to meet the specific operating requirements. Connection of pump and motor is made via a flexible coupling.



F 706 PP-350

Construction features in detail

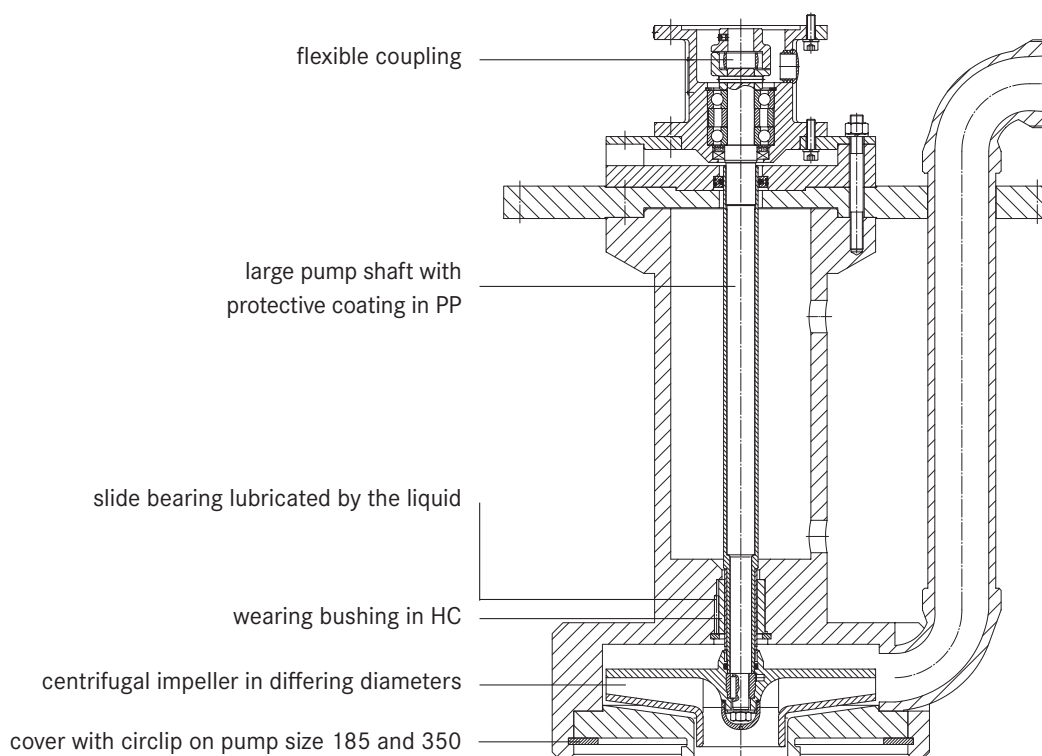

Centrifugal Immersion Pump F 706 PP in polypropylene,

with support tube, without drive motor

Type/Size	F 706 PP-135	F 706 PP-185	F 706 PP-230	F 706 PP-350
Delivery rate Q max.	12 m ³ /h	43 m ³ /h	44 m ³ /h	74 m ³ /h
Delivery head H max.	15 m water column	23 m water column	33 m water column	23 m water column
Viscosity max.	150 mPas	150 mPas	150 mPas	150 mPas
Temperature max.	60 °C	60 °C	60 °C	60 °C
Seal material	no seals in contact with the liquid			
Material	shaft in stainless steel 316 Ti with protective coating in PP, slide bearing in hard carbon or fluorosint			
Centrifugal Impeller in PP	Ø 80 - 100 mm	Ø 100 - 140 mm	Ø 130 - 160 mm	Ø 200 - 250 mm
Pump housing	Ø 174 mm	Ø 249 mm	Ø 264 mm	Ø 417 mm
Mounting flange in PP	outside Ø 250 mm	outside Ø 340 mm	outside Ø 340 mm	outside Ø 500 mm
Thread on outlet	G 1½ A	G 2¼ A	G 2¼ A	G 2¾ A
Motor capacity	0,37 - 0,75 kW n = 2.850 rpm	1,5 - 4,0 kW n = 2.850 rpm	3,0 - 5,5 kW n = 2.850 rpm	3,0 - 5,5 kW n = 1.450 rpm
Part No.				
Immersion length Dimension e 500 mm	10-706 41 105	10-706 41 205	10-706 41 305	10-706 41 405
Immersion length Dimension e 700 mm	10-706 41 107	10-706 41 207	10-706 41 307	10-706 41 407
Immersion length Dimension e 1.000 mm	10-706 41 210	10-706 41 210	10-706 41 310	10-706 41 410

Accessories

Extension tube in PP in steps of 100 mm.

Dimension p up to max. 1.000 mm at size 135 and up to 1.500 mm at sizes 185, 230 and 350.

Suction strainer in PP welded onto the cover of the pump housing or onto the extension tube.

Drive motors for Centrifugal Immersion Pump F 706 PP,

three-phase motors protected to IP 55, with cable terminable box

Capacity P2	Flange Ø	Voltage	Frequency	Nominal speed	Part No.
0,37 kW	120 mm	230/400 V	50 Hz	n = 2.850 rpm	10-001 00 004
0,55 kW	120 mm	230/400 V	50 Hz	n = 2.850 rpm	10-001 00 005
0,75 kW	120 mm	230/400 V	50 Hz	n = 3.000 rpm	10-001 03 376
1,5 kW	160 mm	230/400 V	50 Hz	n = 3.000 rpm	10-001 03 382
2,2 kW	160 mm	230/400 V	50 Hz	n = 3.000 rpm	10-001 03 384
3,0 kW	160 mm	400 V	50 Hz	n = 3.000 rpm	10-001 03 386
4,0 kW	160 mm	400 V	50 Hz	n = 3.000 rpm	10-001 03 388
5,5 kW	160 mm	400 V	50 Hz	n = 3.000 rpm	10-001 03 390

Scope of supply

A complete vertical centrifugal immersion pump consists of: drive motor, pump with mounting flange and necessary accessories.

Weight per pump F 706 PP: 13 - 85 kg depending on the pump size, immersion length and motor kW.

FLUX Centrifugal Immersion Pumps

F 706 PP in polypropylene

Size 135, 185, 230 and 350

Technical data

Performance chart F 706 PP-135

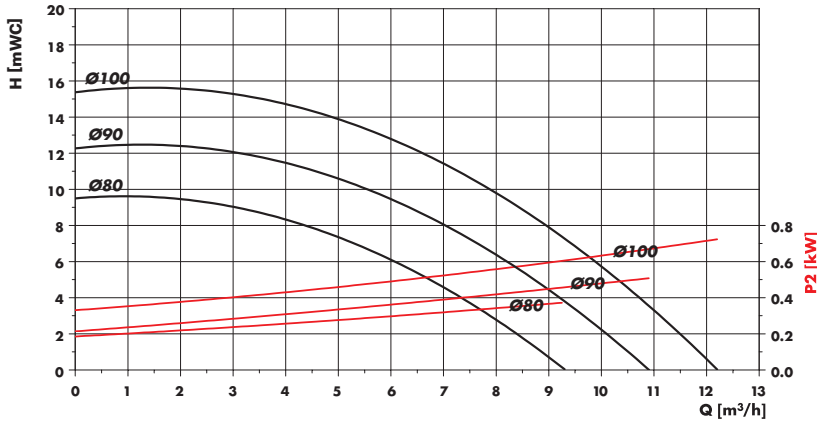

Measured values $\pm 10\%$
determined with water (20 °C).
Nominal speed $n = 2.850$ rpm

In order to obtain the desired output, centrifugal impellers in differing diameters are available.

In determining the absorbed kW of the motor, multiply the absorbed kW shown in the above diagram with the specific gravity of the liquid to be pumped.

Performance chart F 706 PP-185

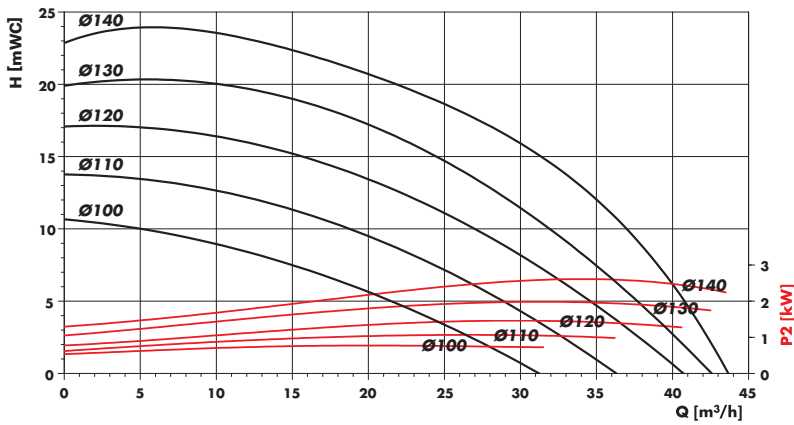

Performance chart F 706 PP-230

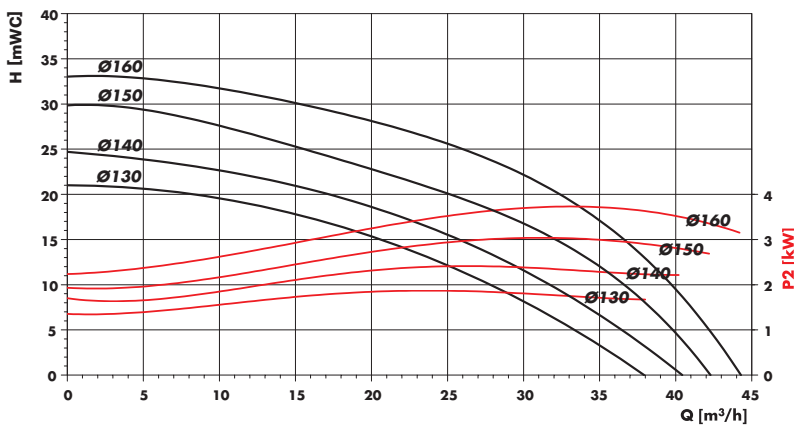

Performance chart F 706 PP-350

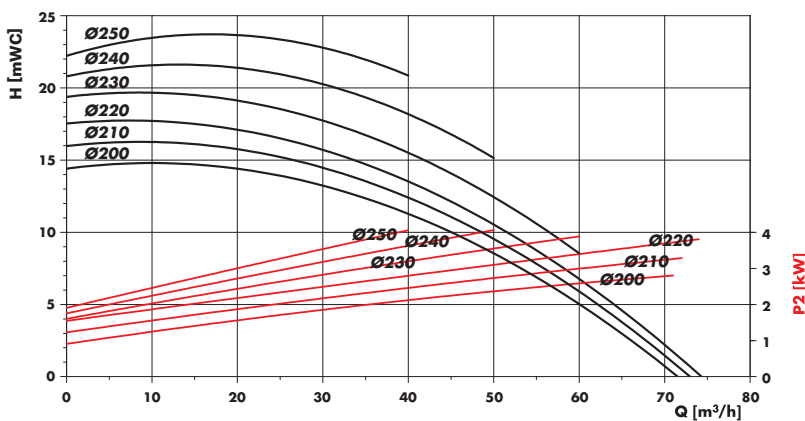

Nominal speed $n = 1.450$ rpm

Technical data

Dimensions F 706 PP-135

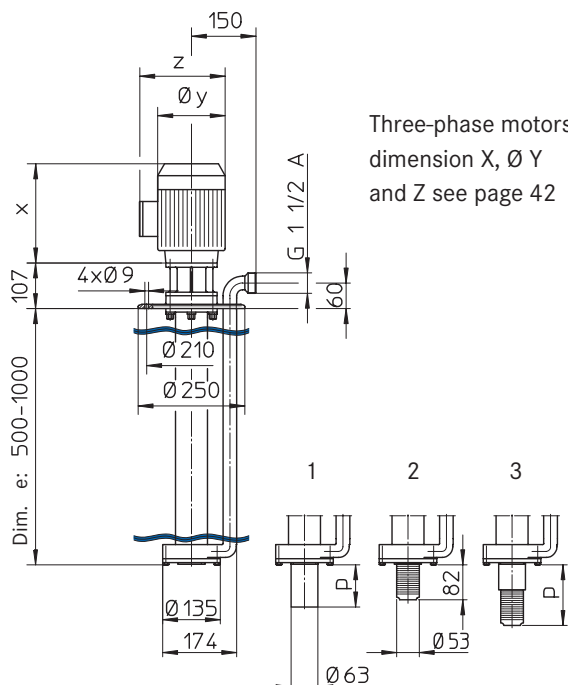

Three-phase motors:
dimension X, Ø Y
and Z see page 42

Basic model
dimension e
max. 1.000 mm

Dimension p
max. 1.000 mm

Dimensions F 706 PP-185

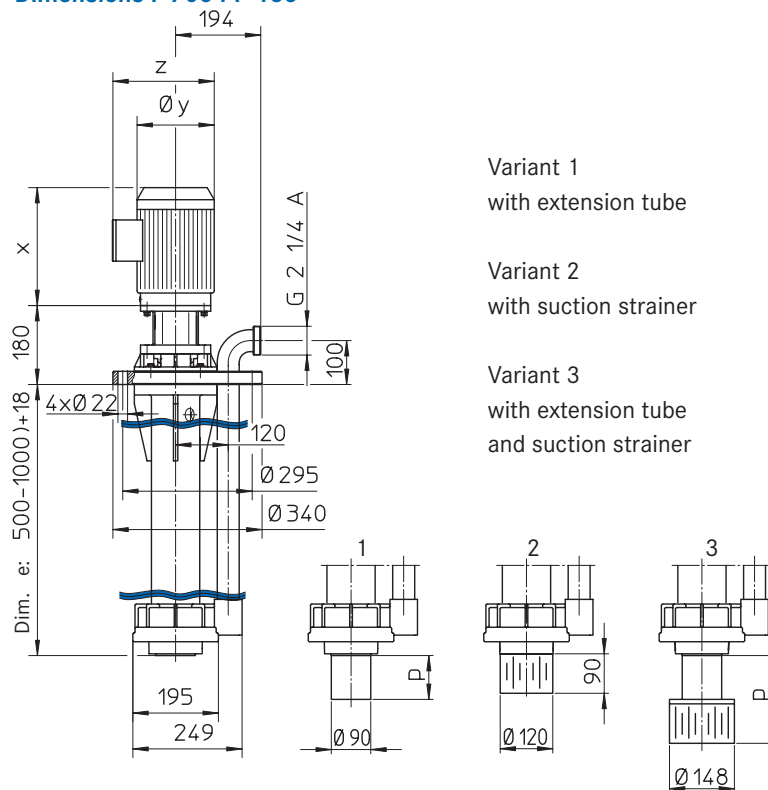

Variant 1
with extension tube

Variant 2
with suction strainer

Variant 3
with extension tube
and suction strainer

Basic model
dimension e
max. 1.000 mm

Dimension p
max. 1.500 mm

Dimensions F 706 PP-230

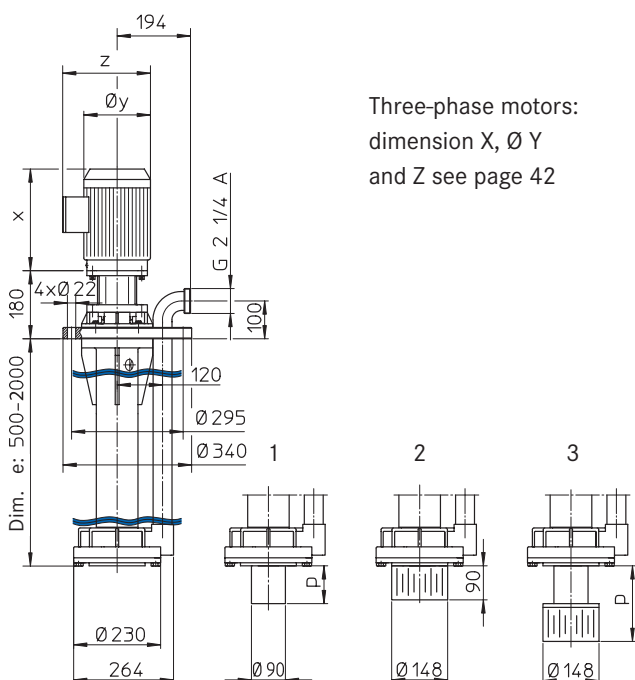

Three-phase motors:
dimension X, Ø Y
and Z see page 42

Basic model
dimension e
max. 2.000 mm

Dimension p
max. 1.500 mm

Dimensions F 706 PP-350

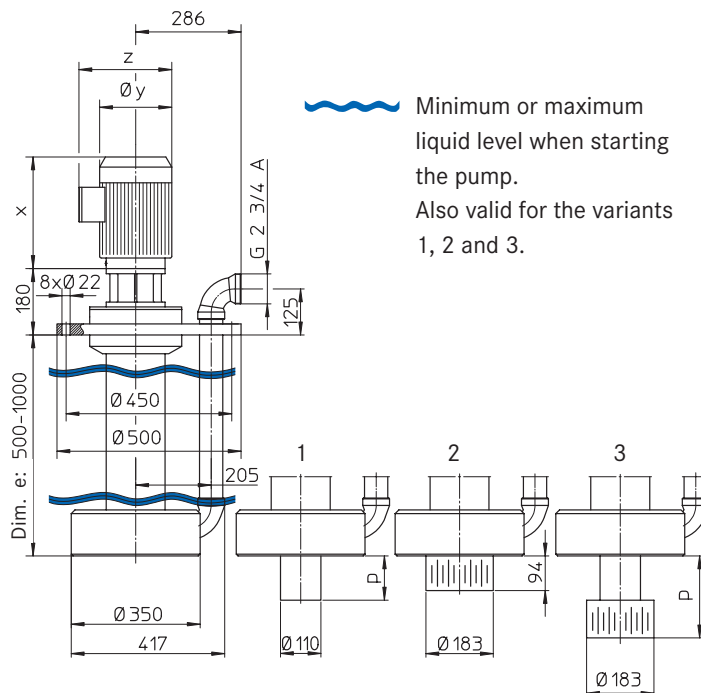

Minimum or maximum
liquid level when starting
the pump.
Also valid for the variants
1, 2 and 3.

Basic model
dimension e
max. 1.000 mm

Dimension p
max. 1.500 mm

FLUX Centrifugal Immersion Pumps

F 716 PP and F 716 PVDF

In polypropylene or polyvinylidenfluoride size 115 and 135

Typical applications

Transferring and circulating of neutral or corrosive liquids in the chemical industry and chemical engineering, electroplating industry, steel or stainless steel pickling plants, flue gas decontamination, exhaust air purification, water and waste water treatment.

Construction features

Vertical centrifugal immersion pump for stationary application. With a compact design requiring very little head room above the mounting flange. This design uses a three-phase motor with extended shaft, especially allowing the pump to use the motor shaft. All wetted parts are made in PP or PVDF. The robust support tube (bars) solidly connected to the mounting flange ensures a very smooth running, prevents the rotating elements from making contact with the pump housing and guarantees a very long service life, even in case of continuous use. As neither bearings nor seals are in contact with the liquid, the pump is very wear-resistant and suitable for dry running operation. The immersion length of the pump can be extended, up to 1.000 mm maximum, by the suction tube option. A suction strainer welded onto the cover of the pump housing or onto the extension tube protects the pump against the ingress of coarse impurities.

A range of carefully chosen impeller diameters, together with a range of three-phase motors in differing kW-ratings, ensures the optimum selection of pumps to meet the specific operating requirements.



F 716 PP1-115

F 716 PVDF2-135

Construction features in detail

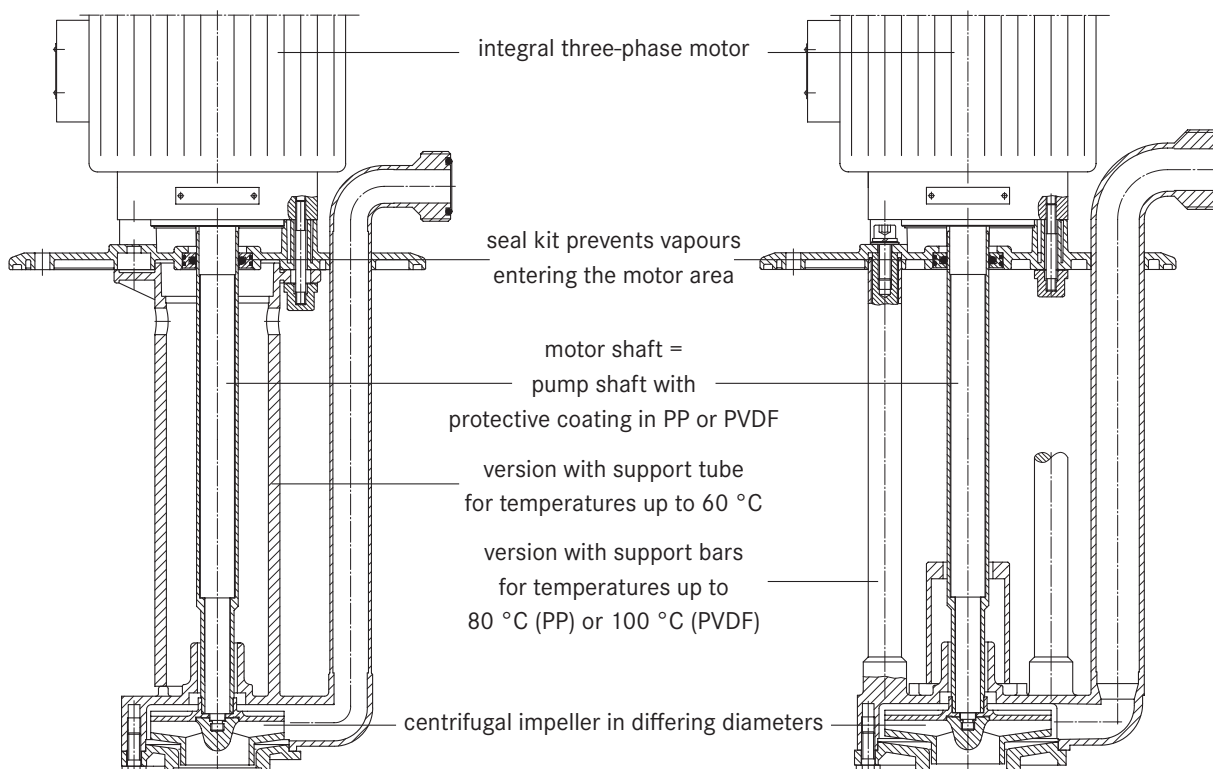

Centrifugal Immersion Pump F 716 PP in polypropylene,

with integral three-phase motor

Type/Size	F 716 PP1-115	F 716 PP2-115	F 716 PP1-135	F 716 PP2-135
Version	with support tube	with support bars	with support tube	with support bars
Delivery rate Q max.	8 m ³ /h	8 m ³ /h	12 m ³ /h	12 m ³ /h
Delivery head H max.	8 m water column	8 m water column	15 m water column	15 m water column
Viscosity max.	150 mPas	150 mPas	150 mPas	150 mPas
Temperature max.	60 °C	80 °C	60 °C	80 °C
Seal material	no bearings nor seals in contact with the liquid			
Material	shaft in stainless steel 316 Ti with protective coating in PP			
Centrifugal impeller in PP	Ø 50 – 80 mm	Ø 50 – 80 mm	Ø 80 – 100 mm	Ø 80 – 100 mm
Pump housing	Ø 150 mm	Ø 150 mm	Ø 174 mm	Ø 174 mm
Mounting flange in PP	Außen-Ø 250 mm	Außen-Ø 250 mm	Außen-Ø 250 mm	Außen-Ø 250 mm
Thread on outlet	G 1¼ A	G 1¼ A	G 1½ A	G 1½ A
Part No.				
Motor capacity P2	0,37 kW	0,37 kW	0,37 kW	0,37 kW
Immersion length Dimension e 300 mm	10-716 41 003	10-716 42 003	10-716 41 103	10-716 42 103
Immersion length Dimension e 400 mm	10-716 41 004	10-716 42 004	10-716 41 104	10-716 42 104
Immersion length Dimension e 500 mm	-	10-716 42 005	-	10-716 42 105
Part No.				
Motor capacity P2	0,55 kW	0,55 kW	0,55 kW	0,55 kW
Immersion length Dimension e 300 mm	10-716 41 013	10-716 42 013	10-716 41 113	10-716 42 113
Immersion length Dimension e 400 mm	10-716 41 014	10-716 42 014	10-716 41 114	10-716 42 114
Immersion length Dimension e 500 mm	-	10-716 42 015	-	10-716 42 115
Part No.				
Motor capacity P2	0,75 kW	0,75 kW	0,75 kW	0,75 kW
Immersion length Dimension e 300 mm	-	-	10-716 41 123	10-716 42 123
Immersion length Dimension e 400 mm	-	-	10-716 41 124	10-716 42 124
Immersion length Dimension e 500 mm	-	-	-	10-716 42 125

Centrifugal Immersion Pump F 716 PVDF in polyvinylidenfluoride,

with integral three-phase motor

Type/Size	F 716 PVDF2-115	F 716 PVDF2-135
Version	with support bars	with support bars
Delivery rate Q max.	8 m ³ /h	12 m ³ /h
Delivery head H max.	8 m water column	15 m water column
Viscosity max.	150 mPas	150 mPas
Temperature max.	100 °C	100 °C
Seal material	no bearings nor seals in contact with the liquid	
Material	shaft in stainless steel 316 Ti with protective coating in PVDF	
Centrifugal impeller in PVDF	Ø 50 – 80 mm	Ø 80 – 100 mm
Pump housing	Ø 150 mm	Ø 174 mm
Mounting flange in PVDF	outside Ø 245 mm	outside Ø 245 mm
Thread on outlet		
Part No.	0,37 kW	0,55 kW
Motor capacity P2	10-716 62 003	10-716 62 013
Immersion length Dimension e 400 mm	10-716 62 004	10-716 62 014
Immersion length Dimension e 500 mm	10-716 62 005	10-716 62 015
	0,37 kW	0,55 kW
	10-716 62 103	10-716 62 113
	10-716 62 104	10-716 62 114
	10-716 62 105	10-716 62 115
	0,75 kW	
	10-716 62 123	10-716 62 124
		10-716 62 125

Accessories

Extension tube in PP or PVDF in steps of 100 mm. Dimension p up to max. 1.000 mm.

Suction strainer in PP or PVDF welded at the cover of the pump housing or at the extension tube.

Scope of supply

A complete vertical centrifugal immersion pump consists of: pump with mounting flange and integral three-phase motor and necessary accessories. Weight per pump: 9 – 15 kg depending on the pump size, immersion length and motor kW.

FLUX Centrifugal Immersion Pumps F 716 PP and F 716 PVDF

In polypropylene or polyvinylidenfluoride size 115 and 135

Technical data

Performance chart F 716 PP1-115, F 716 PP2-115 and F 716 PVDF2-115

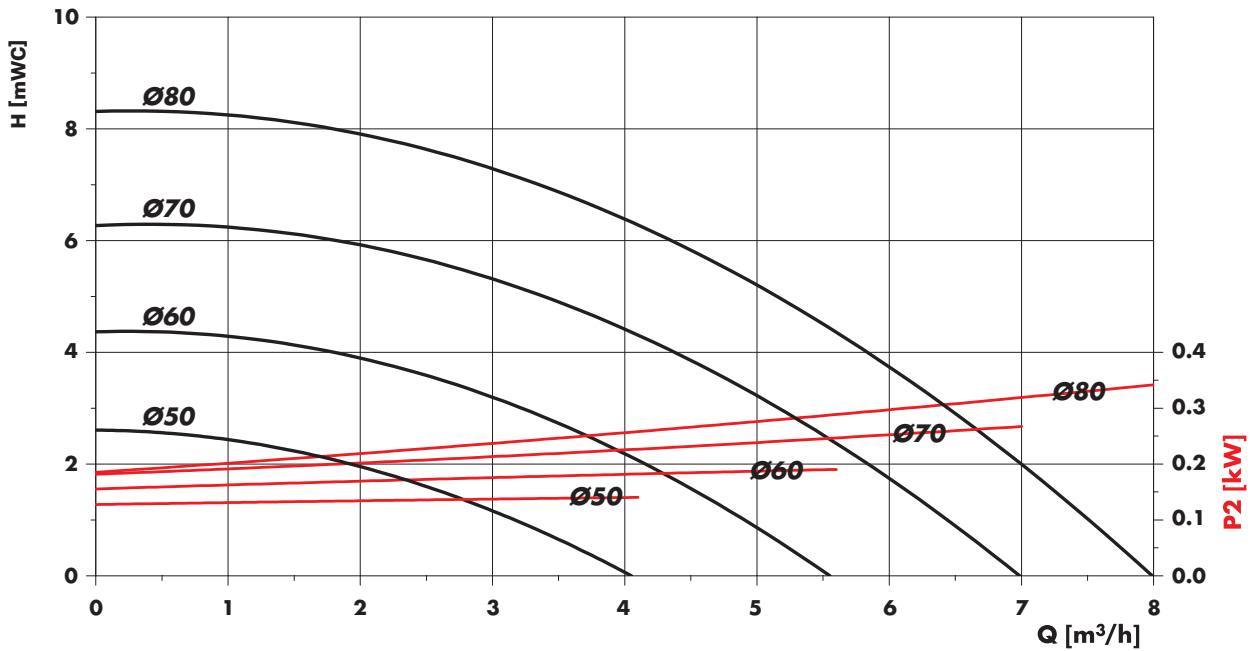

Measured values $\pm 10\%$ determined with water (20 °C). Nominal speed $n = 2.850$ rpm

In order to obtain the desired output, centrifugal impellers in differing diameters are available.

In determining the absorbed kW of the motor, multiply the absorbed kW shown in the above diagram with the specific gravity of the liquid to be pumped.

Performance chart F 716 PP1-135, F 716 PP2-135 and F 716 PVDF2-135

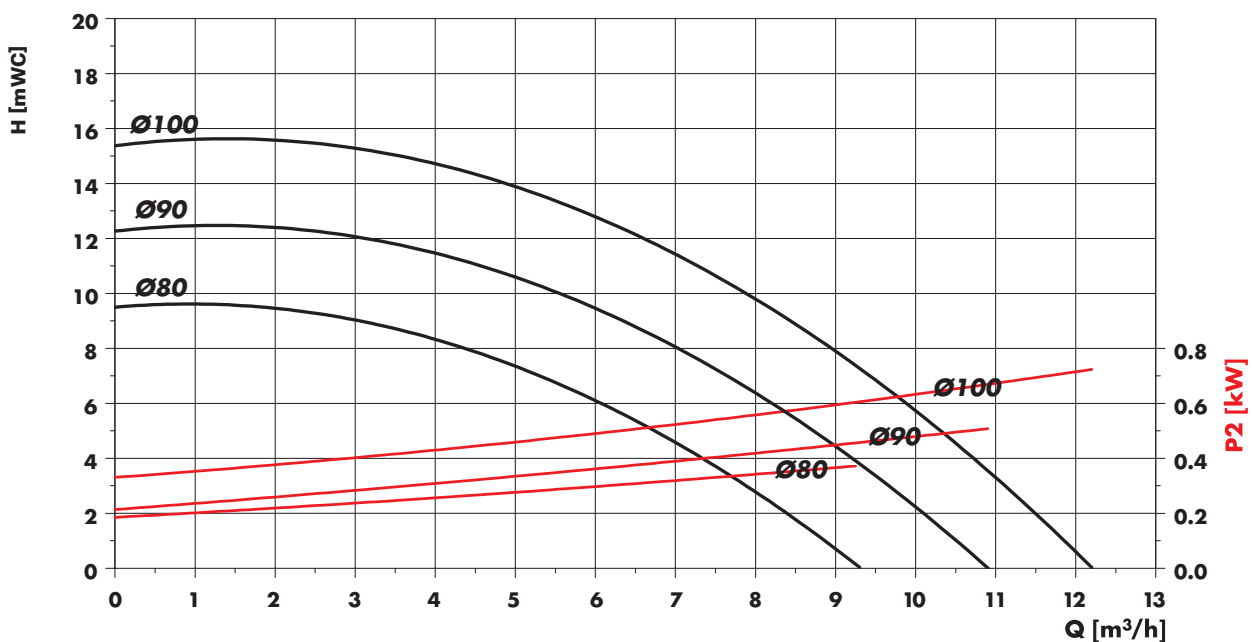

Technical data
Dimensions F 716 PP1-115
Version with support tube

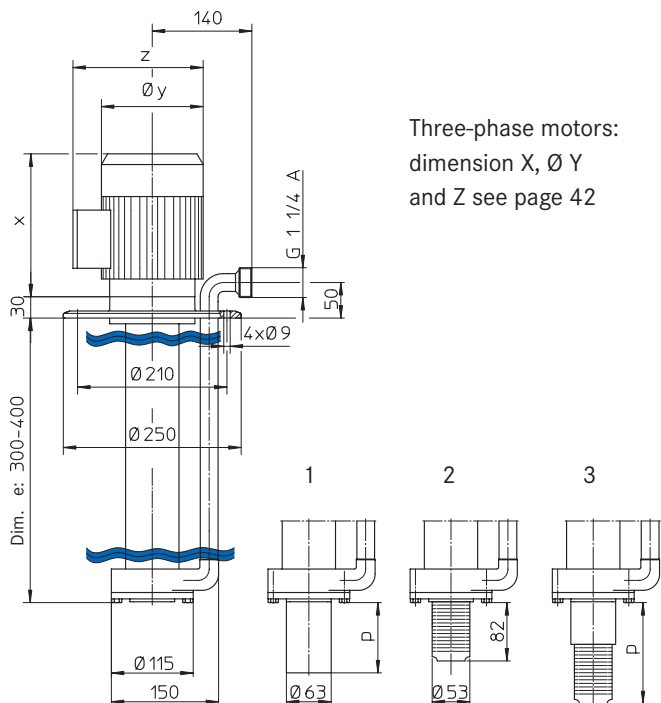

Three-phase motors:
 dimension X, Ø Y
 and Z see page 42

Basic model
 dimension e
 max. 400 mm

Dimension p max. 1.000 mm

Dimensions F 716 PP2-115 and F 716 PVDF2-115
Version with support bars

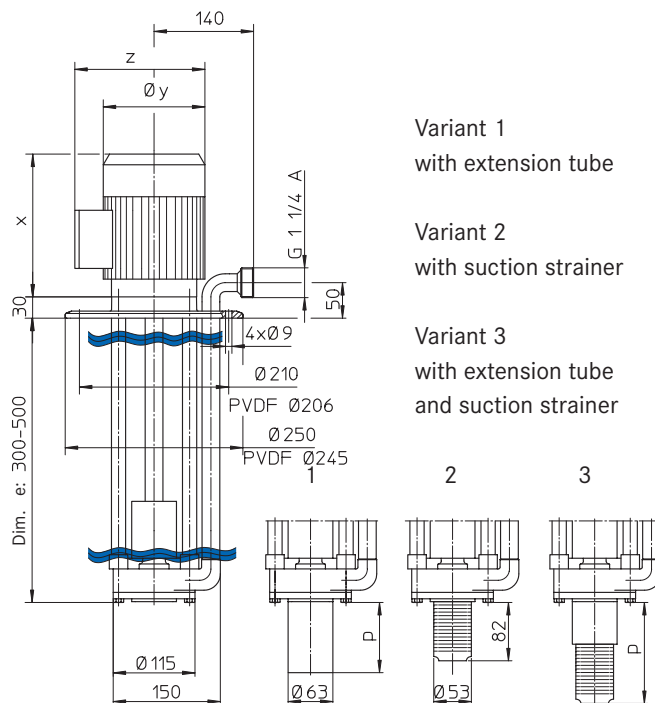

Variant 1
 with extension tube

Variant 2
 with suction strainer

Variant 3
 with extension tube
 and suction strainer

Basic model
 dimension e
 max. 500 mm

Dimension p max. 1.000 mm

Dimensions F 716 PP1-135
Version with support tube

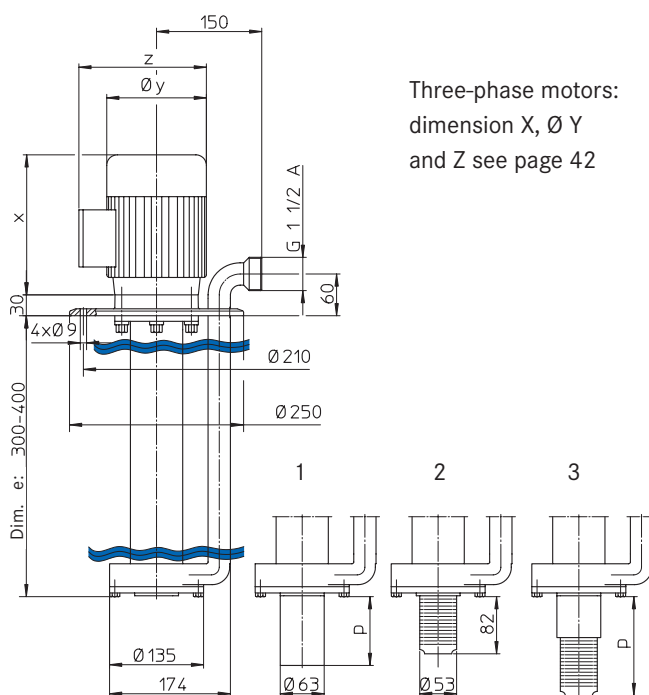

Three-phase motors:
 dimension X, Ø Y
 and Z see page 42

Basic model
 dimension e
 max. 400 mm

Dimension p max. 1.000 mm

Dimensions F 716 PP2-135 and F 716 PVDF2-135
Version with support bars

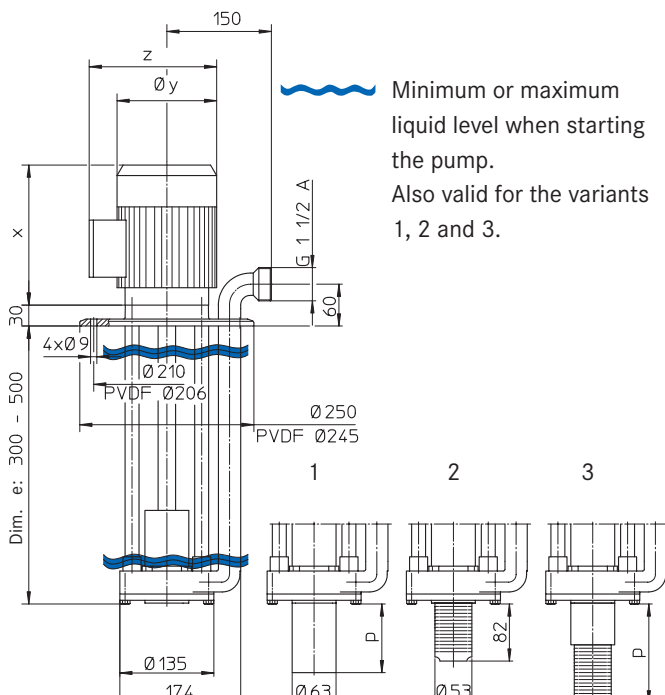

Minimum or maximum
 liquid level when starting
 the pump.
 Also valid for the variants
 1, 2 and 3.

Basic model
 dimension e
 max. 500 mm

Dimension p max. 1.000 mm

FLUX Centrifugal Immersion Pump F 716 PP and F 716 PVDF

In polypropylene or polyvinylidenfluoride size 185 and 230

Typical applications

Transferring and circulating of neutral or corrosive liquids in the chemical industry and chemical engineering, electroplating industry, steel or stainless steel pickling plants, flue gas decontamination, exhaust air purification, water and waste water treatment.

Construction features

Vertical centrifugal immersion pump for stationary application. With a compact design requiring very little head room above the mounting flange. This design uses a three-phase motor with extended shaft, allowing the pump to use the motor shaft. All wetted parts are made in PP or PVDF.

The robust support tube (bars) solidly connected to the mounting flange ensures a very smooth running, prevents the rotating elements from making contact with the pump housing and guarantees a very long service life, even in case of continuous use. As neither bearings nor seals are in contact with the liquid, the pump is very wear-resistant and suitable for dry running operation. The immersion length of the pump can be extended, up to 1.500 mm maximum, by the suction tube option. A suction strainer welded onto the cover of the pump housing or onto the extension tube protects the pump against the ingress of coarse impurities.

A range of carefully chosen impeller diameters, together with a range of three-phase motors in differing kW-ratings, ensures the optimum selection of pumps to meet the specific operating requirements.

Construction features in detail

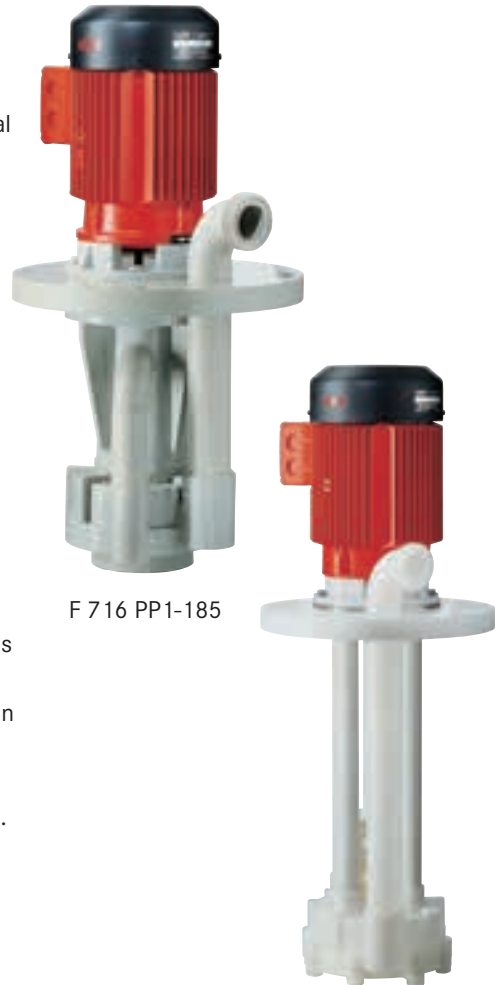
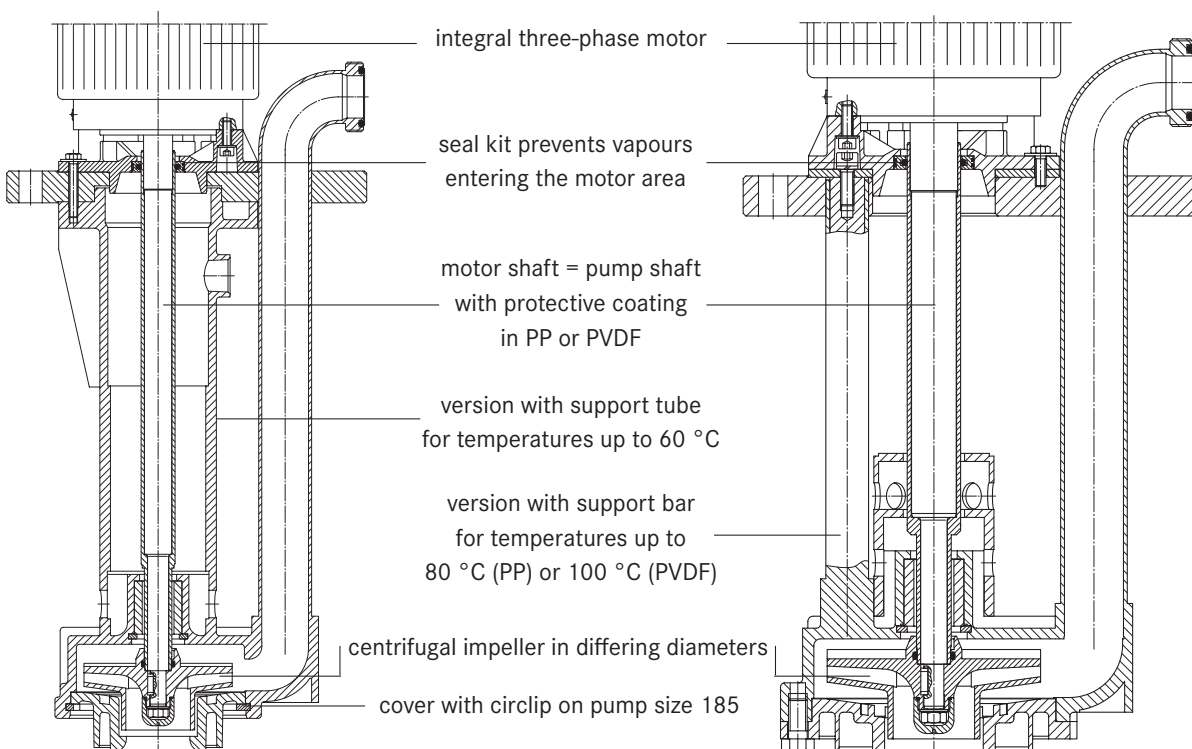

F 716 PP1-185

F 716 PVDF2-230

Centrifugal Immersion Pump F 716 PP in polypropylene,

with integral three-phase motor

Type/Size	F 716 PP1-185	F 716 PP2-185	F 716 PP1-230	F 716 PP2-230
Version	with support tube	with support bars	with support tube	with support bars
Delivery rate Q max.	38 m ³ /h	38 m ³ /h	45 m ³ /h	45 m ³ /h
Delivery head H max.	23 m water column	23 m water column	35 m water column	35 m water column
Viscosity max.	150 mPas	150 mPas	150 mPas	150 mPas
Temperature max.	60 °C	80 °C	60 °C	80 °C
Seal material	no bearings nor seals in contact with the liquid			
Material	shaft in stainless steel 316 Ti with protective coating in PP			
Centrifugal impeller in PP	Ø 100 – 140 mm	Ø 100 – 140 mm	Ø 130 – 160 mm	Ø 130 – 160 mm
Pump housing	Ø 249 mm	Ø 249 mm	Ø 264 mm	Ø 264 mm
Mounting flange in PP	outside Ø 340 mm	outside Ø 340 mm	outside Ø 340 mm	outside Ø 340 mm
Thread on outlet	G 2¼ A	G 2¼ A	G 2¼ A	G 2¼ A
Part No.				
Motor capacity P2	1,5 kW	1,5 kW	3,0 kW	3,0 kW
Immersion length Dimension e 300 mm	10-716 41 203	10-716 42 203	10-716 41 303	10-716 42 303
Immersion length Dimension e 400 mm	10-716 41 204	10-716 42 204	10-716 41 304	10-716 42 304
Immersion length Dimension e 500 mm	10-716 41 205	10-716 42 205	10-716 41 305	10-716 42 305
Motor capacity P2	2,2 kW	2,2 kW	4,0 kW	4,0 kW
Immersion length Dimension e 300 mm	10-716 41 213	10-716 42 213	10-716 41 313	10-716 42 313
Immersion length Dimension e 400 mm	10-716 41 214	10-716 42 214	10-716 41 314	10-716 42 314
Immersion length Dimension e 500 mm	10-716 41 215	10-716 42 215	10-716 41 315	10-716 42 315
Motor capacity P2	3,0 kW	3,0 kW	5,5 kW	5,5 kW
Immersion length Dimension e 300 mm	10-716 41 223	10-716 42 223	10-716 41 323	10-716 42 323
Immersion length Dimension e 400 mm	10-716 41 224	10-716 42 224	10-716 41 324	10-716 42 324
Immersion length Dimension e 500 mm	10-716 41 225	10-716 42 225	10-716 41 325	10-716 42 325
Motor capacity P2	4,0 kW	4,0 kW	-	-
Immersion length Dimension e 300 mm	10-716 41 233	10-716 42 233	-	-
Immersion length Dimension e 400 mm	10-716 41 234	10-716 42 234	-	-
Immersion length Dimension e 500 mm	10-716 41 235	10-716 42 235	-	-

Centrifugal Immersion Pump F 716 PVDF in polyvinylidenfluoride,

with integral three-phase motor

Type/Size	F 716 PVDF2-185	F 716 PVDF2-230		
Version	with support bars	with support bars		
Delivery rate Q max.	38 m ³ /h	45 m ³ /h		
Delivery head H max.	23 m water column	35 m water column		
Viscosity max.	150 mPas	150 mPas		
Temperature max.	100 °C	100 °C		
Seal material	no bearings nor seals in contact with the liquid			
Material	shaft in stainless steel 316 Ti with protective coating in PVDF			
Centrifugal impeller in PVDF	Ø 100 – 140 mm	Ø 130 – 160 mm		
Pump housing	Ø 249 mm	Ø 264 mm		
Mounting flange in RCH1.000	outer Ø 340 mm	outer Ø 340 mm		
Thread on outlet	G 2¼ A	G 2¼ A		
Part No.				
Motor capacity P2	1,5 kW	2,2 kW	3,0 kW	4,0 kW
Immersion length Dimension e 300 mm	10-716 62 203	10-716 62 213	10-716 62 303	10-716 62 313
Immersion length Dimension e 400 mm	10-716 62 204	10-716 62 214	10-716 62 304	10-716 62 314
Immersion length Dimension e 500 mm	10-716 62 205	10-716 62 215	10-716 62 305	10-716 62 315
Motor capacity P2	3,0 kW	4,0 kW	5,5 kW	
Immersion length Dimension e 300 mm	10-716 62 223	10-716 62 233	10-716 62 323	
Immersion length Dimension e 400 mm	10-716 62 224	10-716 62 234	10-716 62 324	
Immersion length Dimension e 500 mm	10-716 62 225	10-716 62 235	10-716 62 325	

Accessories

Extension tube in PP or PVDF in steps of 100 mm. Dimension p up to max. 1.500 mm.

Suction strainer in PP or PVDF welded onto the cover of the pump housing or onto the extension tube.

Weight per pump: 22 – 50 kg depending on the pump size, immersion length and motor kW.

FLUX Centrifugal Immersion Pump F 716 PP and F 716 PVDF

In polypropylene or polyvinylidenfluoride size 185 and 230

Technical data

Performance chart F 716 PP1-185, F 716 PP2-185 and F 716 PVDF2-185

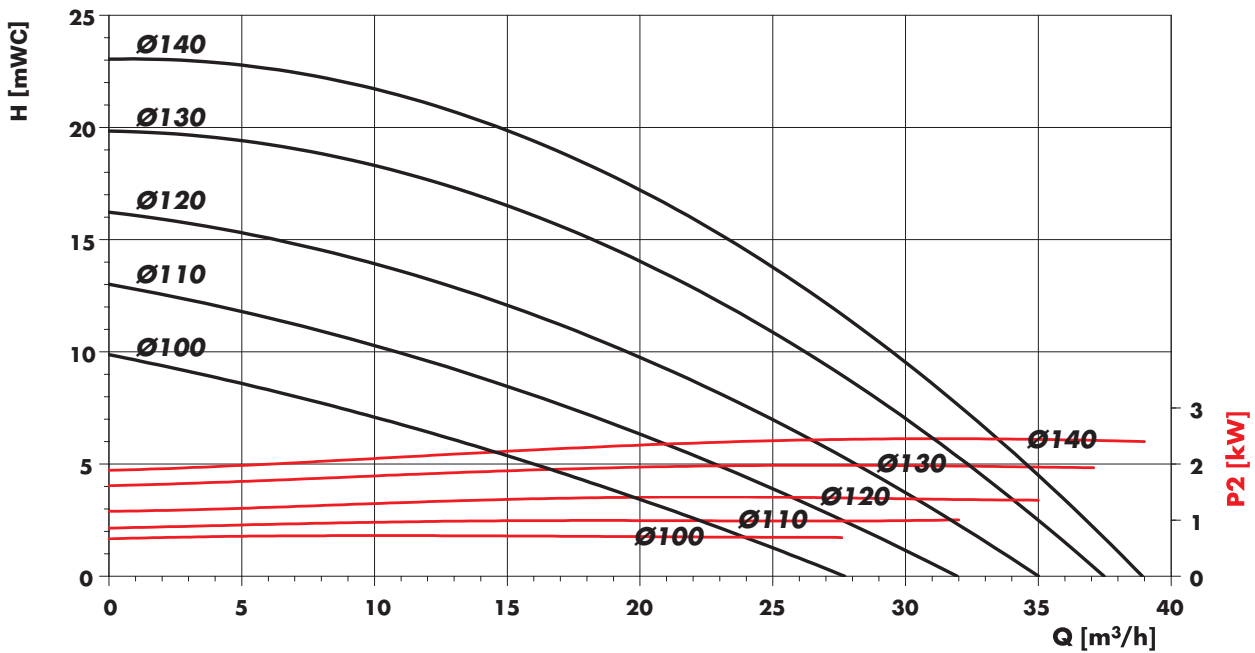

Measured values $\pm 10\%$ determined with water (20 °C). Nominal speed $n = 2.850$ rpm

In order to obtain the desired output, centrifugal impellers in differing diameters are available.

In determining the absorbed kW of the motor, multiply the absorbed kW shown in the above diagram with the specific gravity of the liquid to be pumped.

Performance chart F 716 PP1-230, F 716 PP2-230 and F 716 PVDF2-230

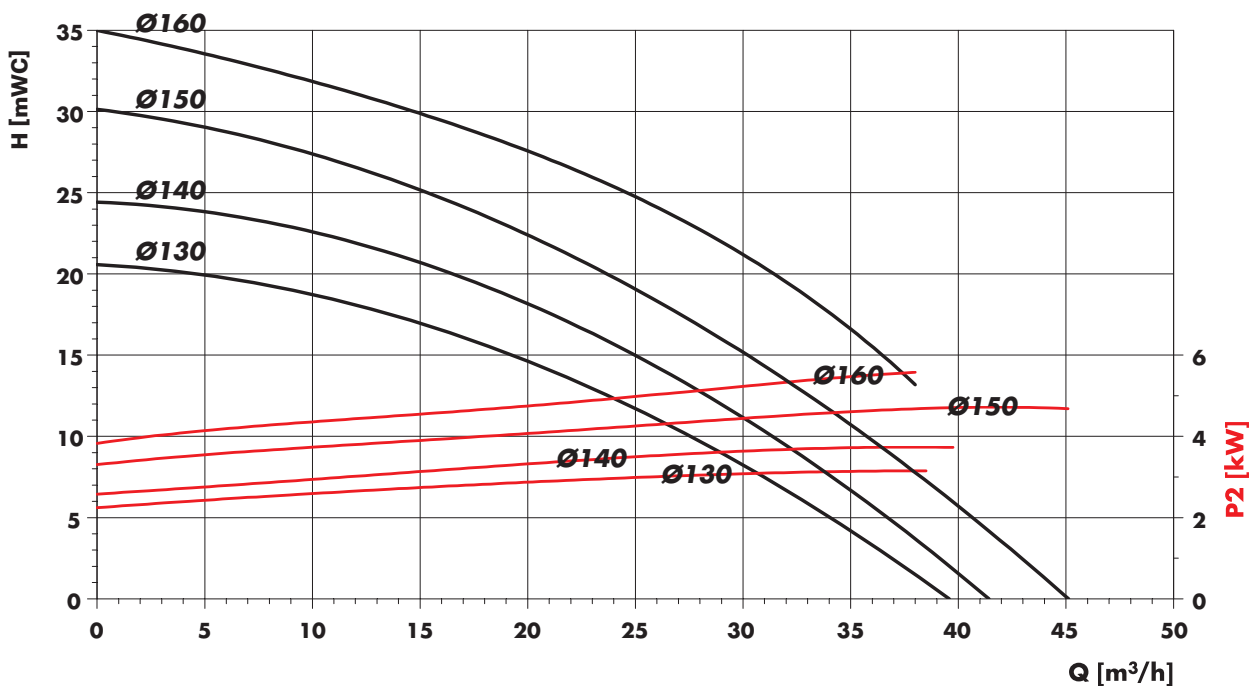

Technical data

Dimensions F 716 PP1-185

Version with support tube

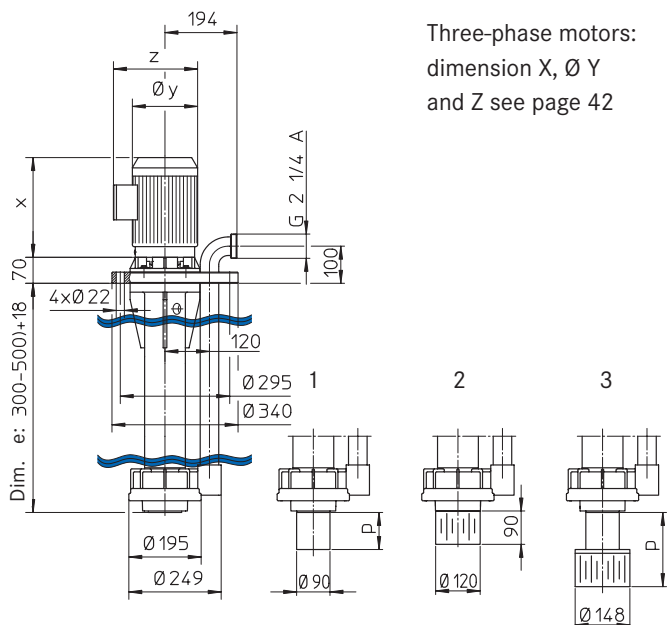

Three-phase motors:
dimension X, Ø Y
and Z see page 42

Basic model
dimension e
max. 500 mm

Dimension p max. 1.500 mm

Dimensions F 716 PP2-185 and F 716 PVDF2-185

Version with support bars

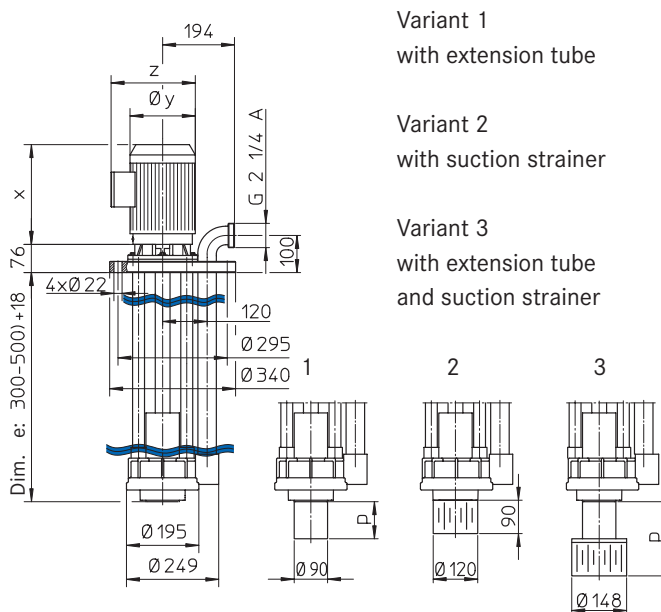

Variant 1
with extension tube

Variant 2
with suction strainer

Variant 3
with extension tube
and suction strainer

Basic model
dimension e
max. 500 mm

Dimension p max. 1.500 mm

Dimensions F 716 PP1-230

Version with support tube

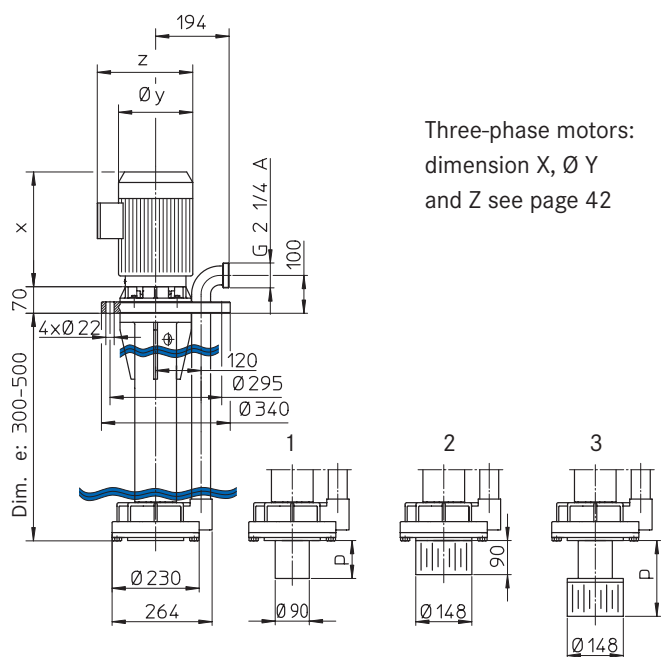

Three-phase motors:
dimension X, Ø Y
and Z see page 42

Basic model
dimension e
max. 500 mm

Dimension p max. 1.500 mm

Dimensions F 716 PP2-230 and F 716 PVDF2-230

Version with support bars

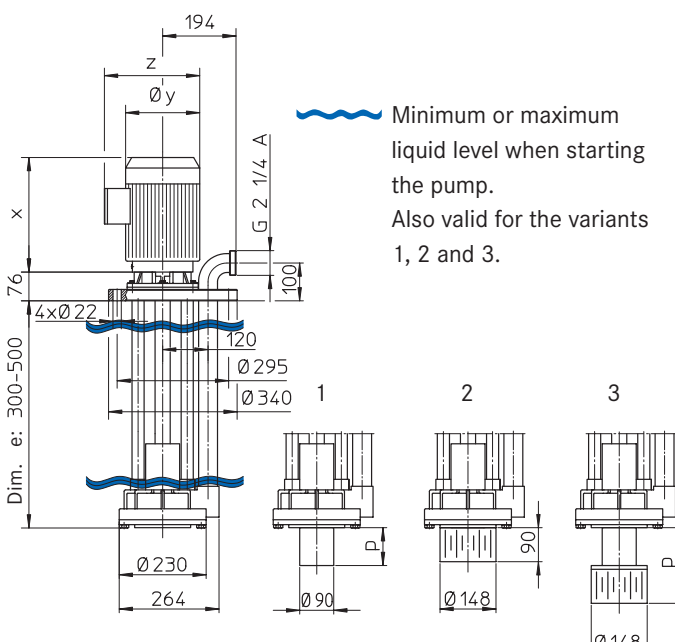

Minimum or maximum
liquid level when starting
the pump.
Also valid for the variants
1, 2 and 3.

Basic model
dimension e
max. 500 mm

Dimension p max. 1.500 mm

FLUX Centrifugal Immersion Pump F 726 PP and F 726 PVDF

In polypropylene or polyvinylidenfluoride size 115 and 135

Typical applications

Transferring and circulating of neutral or corrosive liquids in the whole field of the chemical industry and chemical engineering, electroplating industry, steel or stainless steel pickling plants, flue gas decontamination, exhaust air purification, water and waste-water treatment.

Construction features

Vertical centrifugal immersion pump for stationary application. The robust pump shaft is mounted in an upper pedestal and supported by two antifriction bearings. This construction, with the bearings spaced along the pedestal, ensures that any radial or axial forces are absorbed, even under heavy load. The result is a very smooth running pump. The solid version with support bars prevents the rotating elements from making contact with the pump housing and guarantees a very long service life, even in continuous use applications. As neither bearing nor seals are in contact with the liquid, the pump is very wear-resistant and suitable for dry running operation. The immersion length of the pump can be extended, up to 1.000 mm maximum, by the suction tube option. A suction strainer welded onto the cover of the pump housing or onto the extension tube protects the pump against the ingress of coarse impurities.

A range of carefully chosen impeller diameters, together with a range of three-phase motors in differing kW-ratings, ensures the optimum selection of pumps to meet the specific operating requirements.



F 726 PP2-115



F 726 PVDF2-135

Construction features in detail

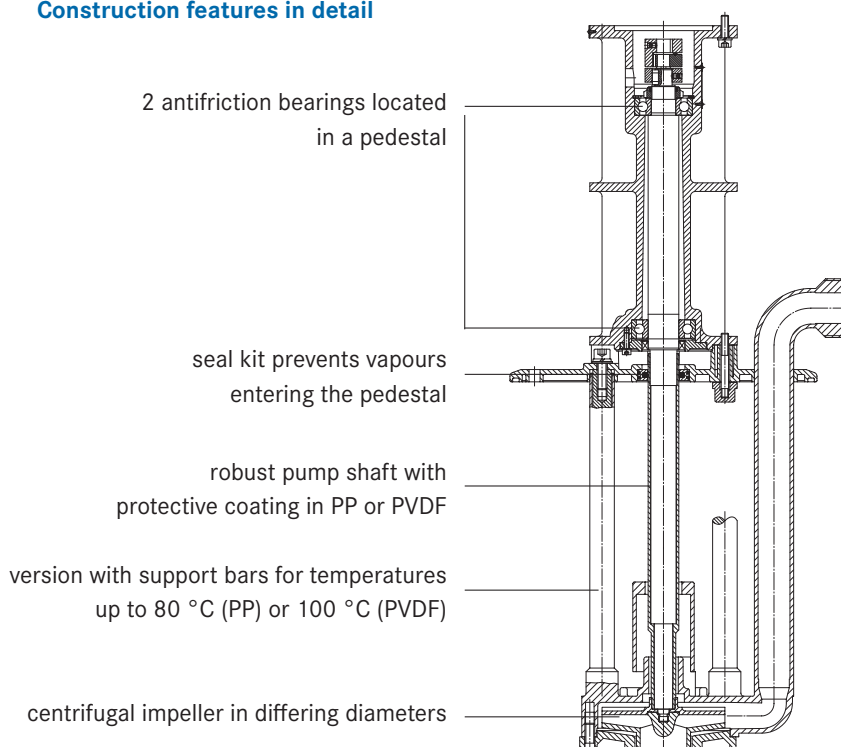

Centrifugal Immersion Pump F 726 PP in polypropylene and F 726 PVDF in polyvinylidenfluoride,

version with support bars, without drive motor

Type/Size	F 726 PP2-115	F 726 PP2-135	F 726 PVDF2-115	F 726 PVDF2-135
Delivery rate Q max.	8 m ³ /h	12 m ³ /h	8 m ³ /h	12 m ³ /h
Delivery head H max.	8 m water column	15 m water column	8 m water column	15 m water column
Viscosity max.	150 mPas	150 mPas	150 mPas	150 mPas
Temperature max.	80 °C	80 °C	100 °C	100 °C
Seal material	no bearings nor seals in contact with the liquid			
Material	shaft in stainless steel 316 Ti with protective coating in PP			
Centrifugal impeller in PP or PVDF	Ø 50 – 80 mm	Ø 80 – 100 mm	Ø 50 – 80 mm	Ø 80 – 100 mm
Pump housing	Ø 150 mm	Ø 174 mm	Ø 150 mm	Ø 174 mm
Mounting flange in PP or PVDF	outside Ø 250 mm	outside Ø 250 mm	outside Ø 245 mm	outside Ø 245 mm
Thread on outlet	G 1¼ A	G 1½ A	G 1¼ A	G 1½ A
Part No.				
Immersion length Dimension e 300 mm	10-726 42 003	10-726 42 103	10-726 62 003	10-726 62 103
Immersion length Dimension e 400 mm	10-726 42 004	10-726 42 104	10-726 62 004	10-726 62 104
Immersion length Dimension e 500 mm	10-726 42 005	10-726 42 105	10-726 62 005	10-726 62 105

Accessories

Extension tube in PP or PVDF in steps of 100 mm. Dimension p up to. max. 1.000 mm.

Suction strainer in PP or PVDF welded onto the cover of the pump housing or onto the extension tube.

Drive motors for Centrifugal Immersion Pump F 726 PP and F 726 PVDF,

three-phase motors protected to IP 55, with cable terminable box

Capacity P2	Flange Ø	Voltage	Frequency	Nominal speed	Part No.
0,37 kW	120 mm	230/400 V	50 Hz	2.850 rpm	10-001 00 004
0,55 kW	120 mm	230/400 V	50 Hz	2.850 rpm	10-001 00 005
0,75 kW	120 mm	230/400 V	50 Hz	3.000 rpm	10-001 03 376

Scope of supply

A complete vertical centrifugal immersion pump consists of: drive motor, pump with mounting flange and the necessary accessories. Weight per pump 17 – 30 kg depending on the pump size, immersion length and motor kW.

FLUX Centrifugal Immersion Pump F 726 PP and F 726 PVDF

In polypropylene or polyvinylidenfluoride size 115 and 135

Technical data

Performance chart F 726 PP2-115 and F 726 PVDF2-115

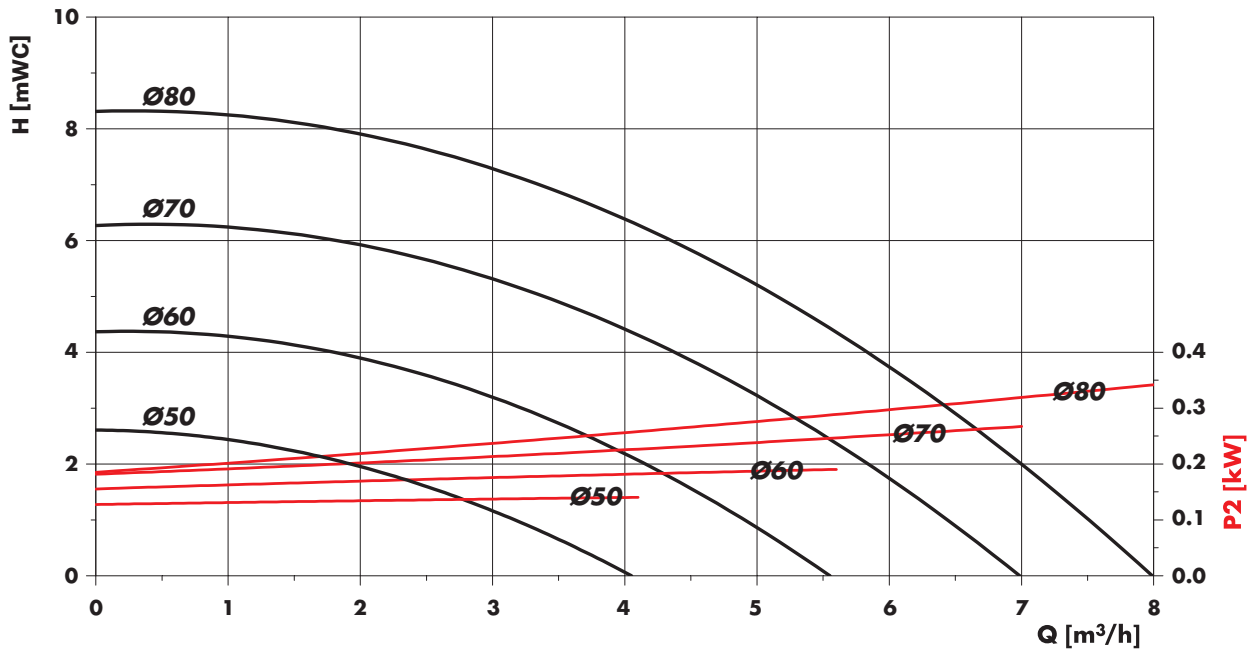

Measured values $\pm 10\%$ determined with water (20 °C). Nominal speed $n = 2.850$ rpm

In order to achieve the desired output, centrifugal impellers in differing diameters are available.

In determining the absorbed kW of the motor, multiply the absorbed kW shown in the above diagram with the specific gravity of the liquid to be pumped.

Performance chart F 726 PP2-135 and F 726 PVDF2-135

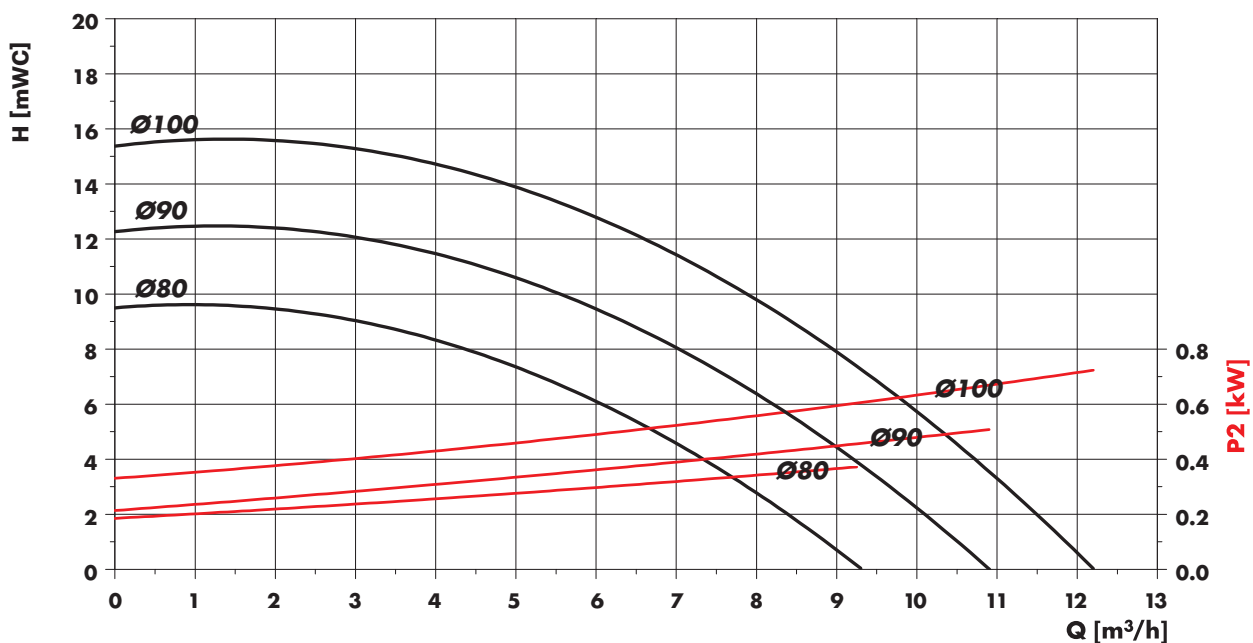

Technical data

Dimensions F 726 PP2-115 and F 726 PVDF2-115

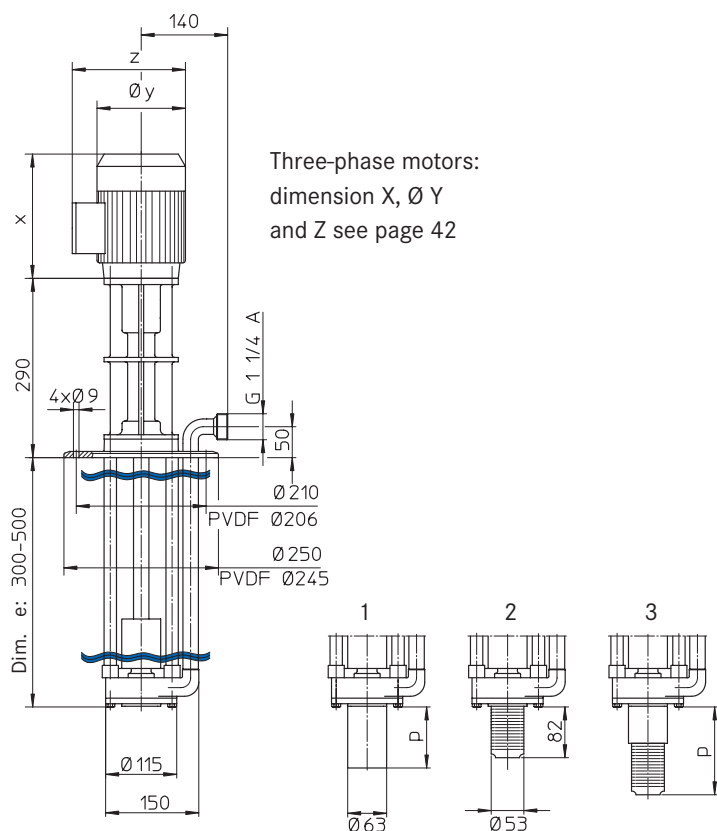

Basic model
dimension e max. 500 mm

Variant 1
with extension tube
dimension p max. 1.000 mm

Variant 2
with suction strainer

Variant 3
with extension tube
and suction strainer

Dimensions F 726 PP2-135 and F 726 PVDF2-135

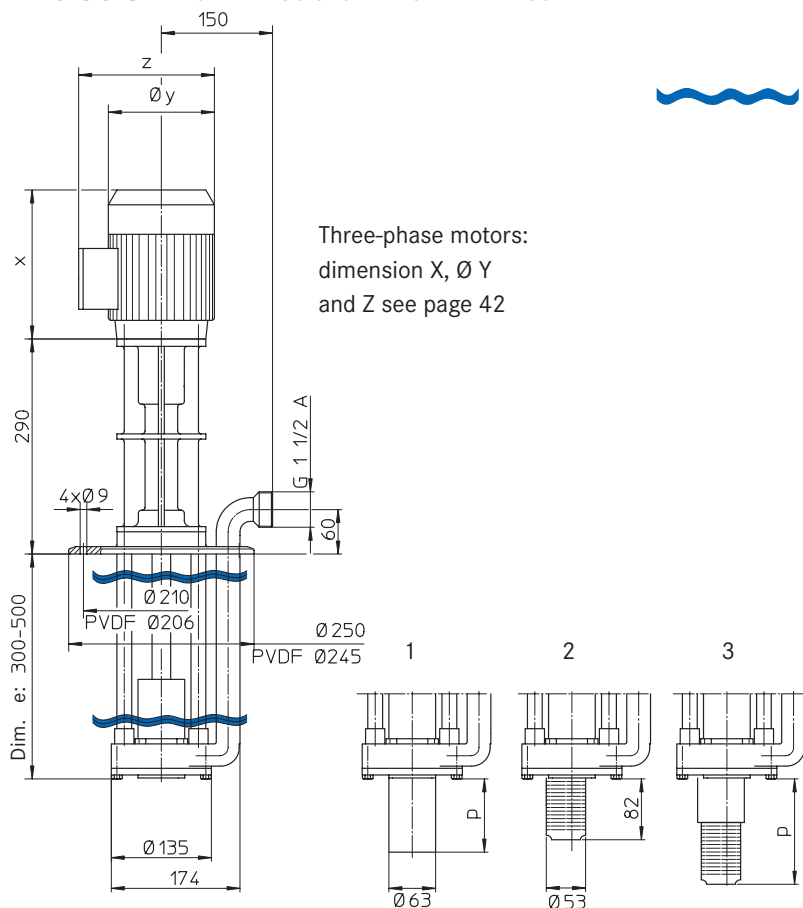

Minimum or maximum liquid level
when starting the pump.
Also valid for the variants 1, 2 and 3.

Basic model
dimension e max. 500 mm

Variant 1
with extension tube
dimension p max. 1.000 mm

Variant 2
with suction strainer

Variant 3
with extension tube
and suction strainer

FLUX Centrifugal Immersion Pump F 726 PP and F 726 PVDF

In polypropylene or polyvinylidenfluoride size 185 and 230

Typical applications

Transferring and circulating of neutral or corrosive liquids in the whole field of the chemical industry and chemical engineering, electroplating industry, steel or stainless steel pickling plants, flue gas decontamination, exhaust air purification, water and waste-water treatment.

Construction features

Vertical centrifugal immersion pump for stationary application. The robust pump shaft is mounted in an upper pedestal and supported by two antifriction bearings. This construction, with the bearings spaced along the pedestal, ensures that any radial or axial forces are absorbed, even under heavy load. The result is a very smooth running pump. The solid version with support bars prevents the rotating elements from making contact with the pump housing and guarantees a very long service life, even in continuous use applications. As neither bearing nor seals are in contact with the liquid, the pump is very wear-resistant and suitable for dry running operation. The immersion length of the pump can be extended, up to 1.500 mm maximum, by the suction tube option. A suction strainer welded onto the cover of the pump housing or onto the extension tube protects the pump against the ingress of coarse impurities.

A range of carefully chosen impeller diameters, together with a range of three-phase motors in differing kW-ratings, ensures the optimum selection of pumps to meet the specific operating requirements.



F 726 PP2-185



F 726 PVDF2-230

Construction features in detail

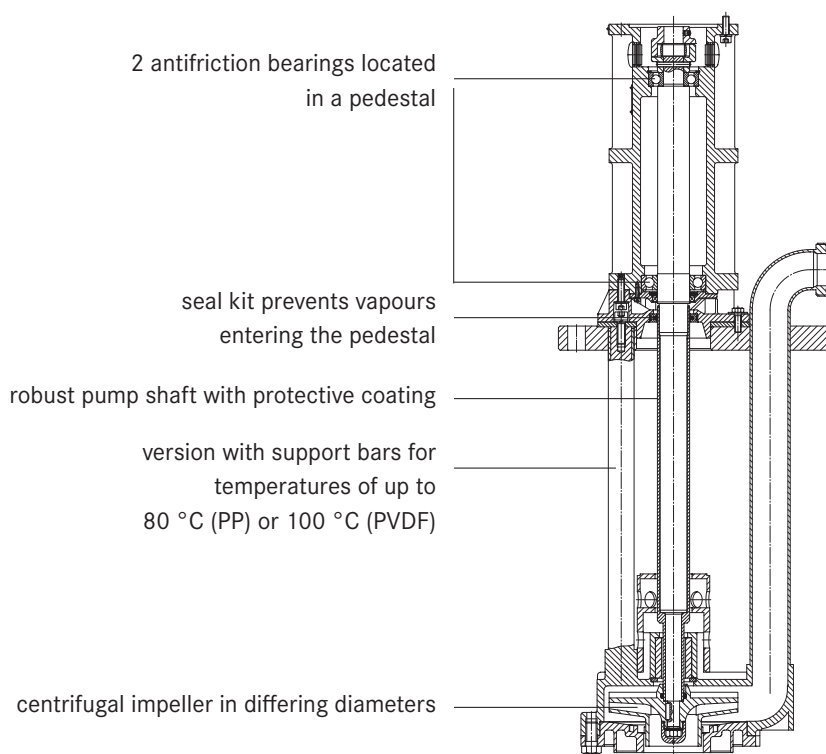

Centrifugal Immersion Pump F 726 PP in polypropylene and F 726 PVDF in polyvinylidenfluoride,

version with support bars, without drive motor

Type/Size	F 726 PP2-185	F 726 PP2-230	F 726 PVDF2-185	F 726 PVDF2-230
Delivery rate Q max.	38 m ³ /h	45 m ³ /h	38 m ³ /h	45 m ³ /h
Delivery head H max.	23 m water column	35 m water column	23 m water column	35 m water column
Viscosity max.	150 mPas	150 mPas	150 mPas	150 mPas
Temperature max.	80 °C	80 °C	100 °C	100 °C
Seal material	no bearings nor seals in contact with the liquid			
Material	shaft in stainless steel 316 Ti with protective coating in PP			
Centrifugal impeller in PP or PVDF	Ø 100 - 140 mm	Ø 130 - 160 mm	Ø 100 - 140 mm	Ø 130 - 160 mm
Pump housing	Ø 249 mm	Ø 264 mm	Ø 249 mm	Ø 264 mm
Mounting flange in PP or RCH 1.000	outside Ø 340 mm	outside Ø 340 mm	outside Ø 340 mm	outside Ø 340 mm
Thread on outlet	G 2¼ A	G 2¼ A	G 2¼ A	G 2¼ A
Part No.				
Immersion length Dimension e 300 mm	10-726 42 203	10-726 42 303	10-726 62 203	10-726 62 303
Immersion length Dimension e 400 mm	10-726 42 204	10-726 42 304	10-726 62 204	10-726 62 304
Immersion length Dimension e 500 mm	10-726 42 205	10-726 42 305	10-726 62 205	10-726 62 305

Accessories

Extension tube in PP or PVDF in steps of 100 mm, Dimension p up to max. 1500 mm.

Suction strainer in PP or PVDF welded onto the cover of the pump housing or onto the extension tube.

Drive motor for Centrifugal Immersion Pump F 726 PP and F 726 PVDF,

three-phase motors protected to IP 55, with cable terminal box

Capacity P2	Flange Ø	Voltage	Frequency	Nominal speed	Part No.
1,5 kW	160 mm	230/400 V	50 Hz	3.000 rpm	10-001 03 382
2,2 kW	160 mm	230/400 V	50 Hz	3.000 rpm	10-001 03 384
3,0 kW	160 mm	400 V	50 Hz	3.000 rpm	10-001 03 386
4,0 kW	160 mm	400 V	50 Hz	3.000 rpm	10-001 03 388
5,5 kW	160 mm	400 V	50 Hz	3.000 rpm	10-001 03 390

Scope of supply

A complete vertical centrifugal immersion pump consists of: drive motor, pump with mounting flange and the necessary accessories. Weight per pump 25 - 75 kg depending on the pump size, immersion length and motor kW.

FLUX Centrifugal Immersion Pump F 726 PP and F 726 PVDF

In polypropylene or polyvinylidenfluoride size 185 and 230

Technical data

Performance chart F 726 PP2-185 and F 726 PVDF2-185

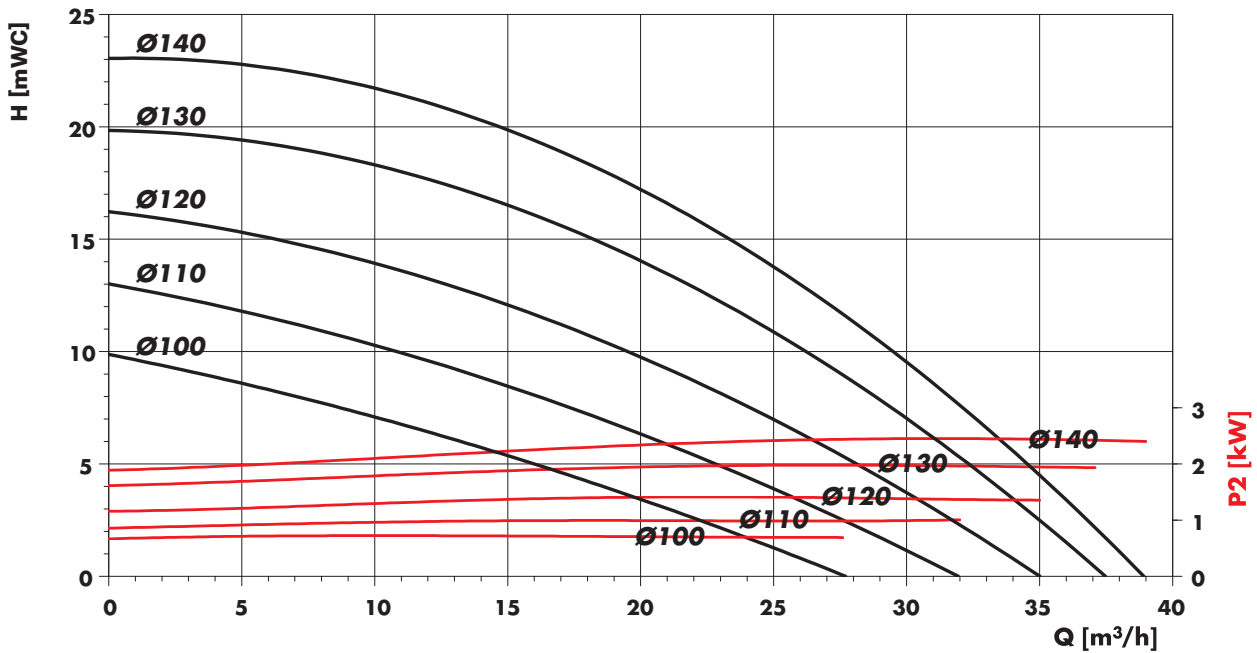

Measured values $\pm 10\%$ determined with water (20 °C). Nominal speed $n = 2.850$ rpm

In order to achieve the desired output, centrifugal impellers in differing diameters are available.

In determining the absorbed kW of the motor, multiply the absorbed kW shown in the above diagram with the specific gravity of the liquid to be pumped.

Performance chart F 726 PP2-230 and F 726 PVDF2-230

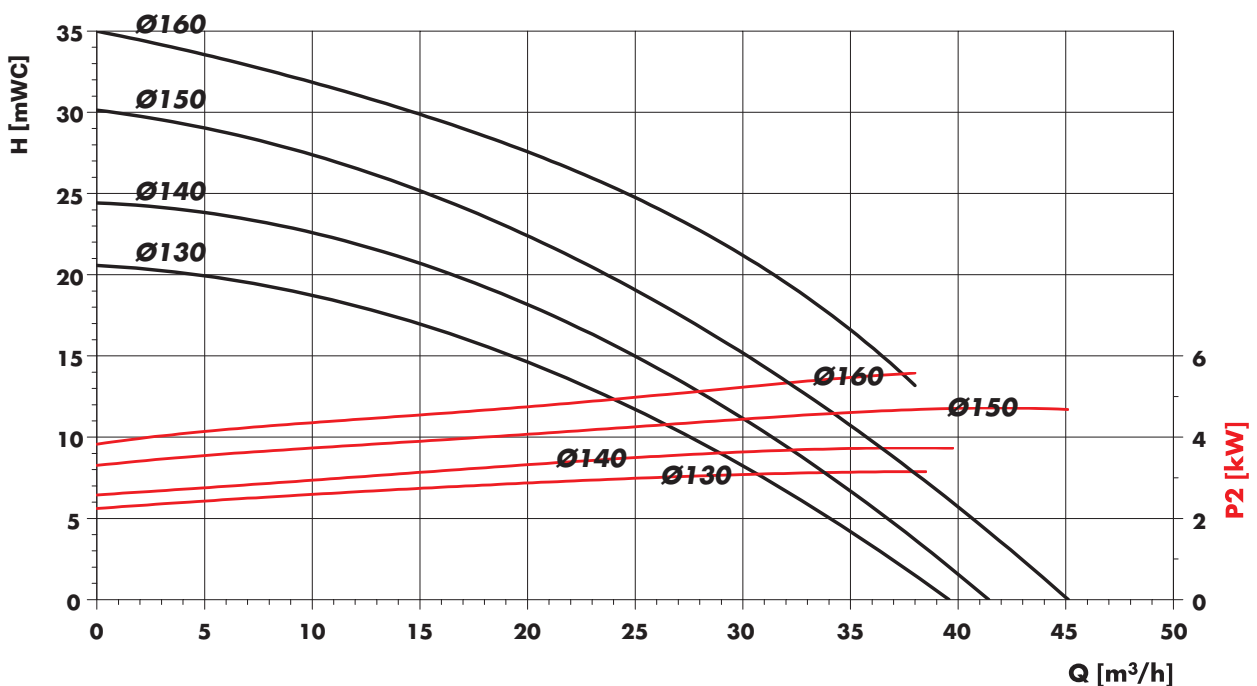

Technical data

Dimensions F 726 PP2-185 and F 726 PVDF2-185

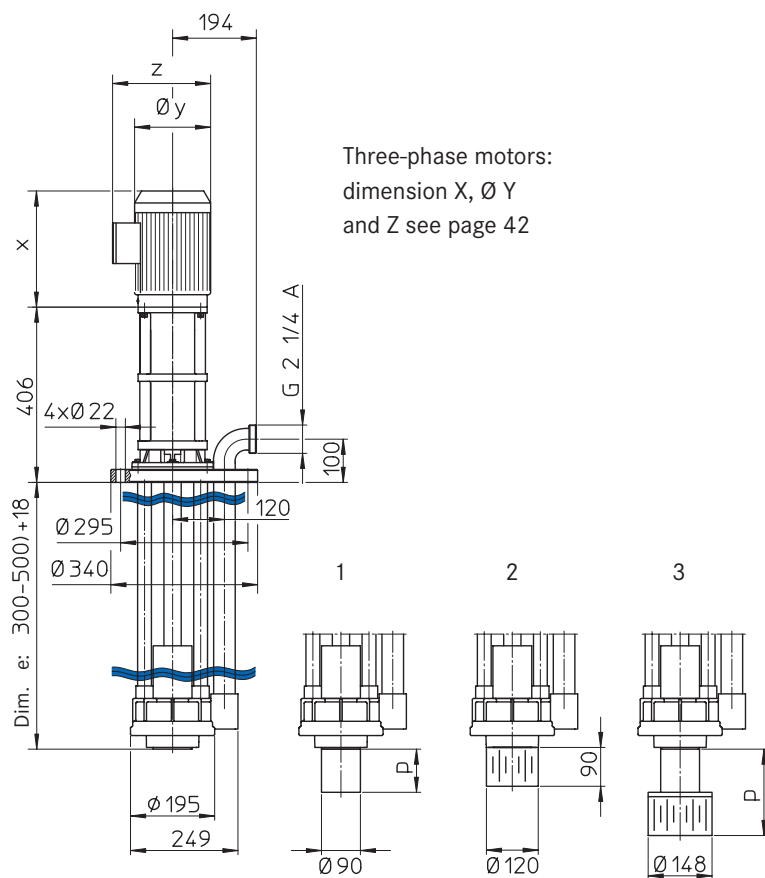

Basic model
dimension e max. 500 mm

Variant 1
with extension tube
dimension p max. 1.500 mm

Variant 2
with suction strainer

Variant 3
with extension tube
and suction strainer

Dimensions F 726 PP2-230 and F 726 PVDF2-230

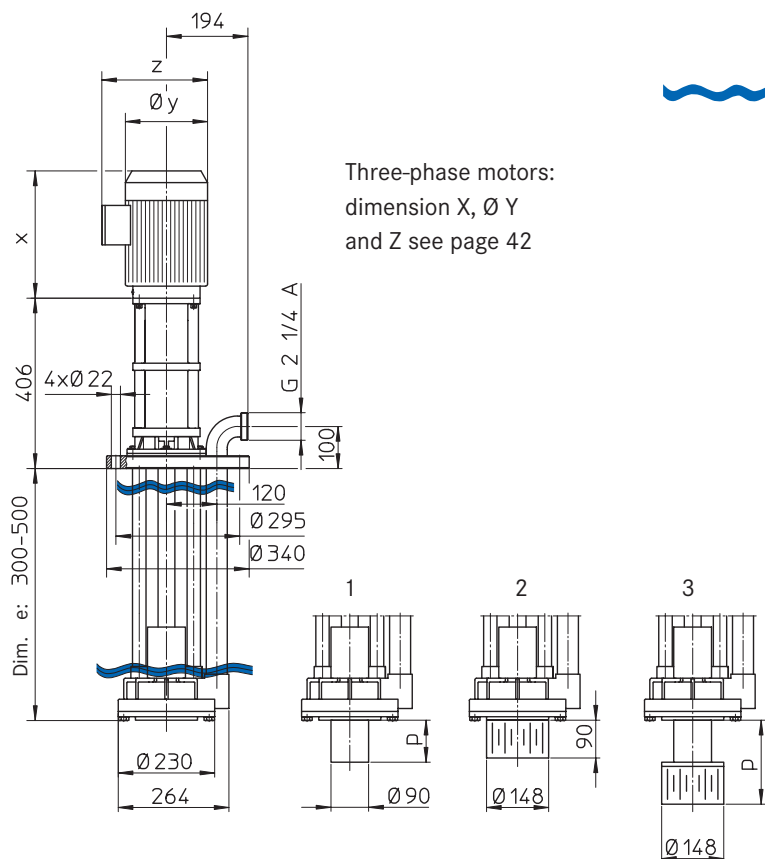

Minimum or maximum liquid level
when starting the pump.
Also valid for the variants 1, 2 and 3.

Basic model
dimension e max. 500 mm

Variant 1
with extension tube
dimension p max. 1.500 mm

Variant 2
with suction strainer

Variant 3
with extension tube
and suction strainer

Dimensions of three-phase motors protected to IP 55

Dimensions

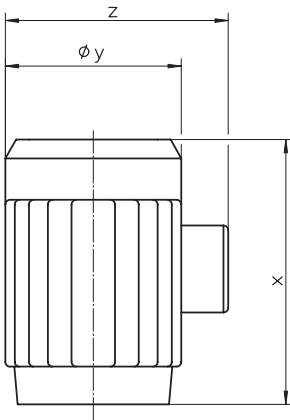

Capacity P2	Nominal speed	X	Ø Y	Z
0,37 kW	2.850 rpm	201	143	183
0,55 kW	2.850 rpm	201	143	183
0,75 kW	2.850 rpm	232	158	201
1,1 kW	2.850 rpm	232	158	201
1,5 kW	2.850 rpm	244	176	227
2,2 kW	2.850 rpm	269	176	227
3,0 kW	2.850 rpm	303	196	252
4,0 kW	2.850 rpm	320	220	277
5,5 kW	2.850 rpm	405	246	313
3,0 kW	1.450 rpm	303	196	252
4,0 kW	1.450 rpm	320	220	277
5,5 kW	1.450 rpm	405	246	313

Questionnaire

FLUX Vertical Centrifugal Immersion Pumps



Requested version

for portable application for stationary application for horizontal application

Liquid data

Description _____ Chemical Formula _____
Concentration _____ % Specific gravity _____ g/cm³
Viscosity _____ mPas/cP at _____ °C Operating temperature _____ °C
Solids in suspension _____ g/l hard soft Size of solids _____ mm
Does liquid crystallize? Yes No at _____ °C
Which materials are resistant to liquid according to previous experience?

Operating data

Delivery rate _____ m³/h Delivery head _____ m water column
Immersion length _____ mm Suction strainer Yes No
Mounting flange in special dimensions: Extension tube Yes No
outside Ø _____ mm, p.c. Ø _____ mm Dimension p = _____ mm
pressure flange Yes No
outside Ø _____ mm, p.c. Ø _____ mm Ø of the container opening _____ mm
Operating time per day _____ Number of starts _____

Drive motor

Three-phase motor Operating voltage _____ Volt _____ Hz
Is motor to be explosion-proof? Yes No

Quotation to be sent by:

Telephone E-Mail Telefax

Mr. / Mrs: _____ Title: _____

Company: _____

Address: _____

ZIP / City / Country: _____

Phone: _____ Telefax: _____

Mobile: _____ E-Mail: _____



More than just pumps

Today the FLUX name is recognised around the globe as the trademark for top standards in pump technology. Everything started with the invention of the electric drum pump in 1950. Nowadays FLUX has an extensive range of products each of which can be customized. FLUX pumps are used for example in the chemical and pharmaceutical industries; in machinery and plant engineering as well as companies in electroplating, effluent treatment and the foodstuffs sector.

Whether single-product or system solution – FLUX quality is synonymous with a long service life, excellent economy and maximum safety.

In addition to the excellent product quality FLUX customers appreciate the superb level of expertise our staff has to offer as well as their genuine customer focus.

These days FLUX-GERÄTE GMBH supplies pumps to almost 100 countries around the globe.

