

Haas ST-40 Series Lathes



The High-Performance Turning Centers

The ST-40L provides 2032 mm of Z-axis travel and includes a programmable servo tailstock; and a steady rest provision is available for additional support

ISO standard G-code programming through the user-friendly, full-function Haas CNC control, or use the optional Intuitive Programming System



2400-rpm high-torque spindle;
29,8 kW vector dual drive

Fully programmable
servo tailstock available

Belt-type chip
conveyor available

Warranty: 1 Year Parts and Labor

[Standard Features]

- 381 mm Hydraulic Chucking System
- A2-8 Spindle Nose
- 102 mm Bar Capacity
- Extended Tool Pocket
- 15" Color LCD Monitor
- Built-In USB Port
- 1 MB Program Memory
- Remote Jog Handle w/Color LCD
- Rigid Tapping
- User-Friendly Haas Control
- Made in the USA

[ST-40]

- 648 x 1118 mm Max Capacity
- 2 400-rpm Spindle
- 29,8 kW Vector Drive
- 12-Station BOT Turret

[ST-40L]

- 648 x 2032 mm Max Capacity
- 2 400-rpm Spindle
- 29,8 kW Vector Drive
- 12-Station BOT Turret
- Programmable Servo Tailstock

[Options] partial list

- 178 mm Big-Bore Spindle Option
- 41 kW Extra-Performance Option
- Programmable servo Tailstock ¹
- Live Tooling with C Axis
- High-Pressure Coolant Systems
- Automatic Tool Presetter System
- Belt-Type Chip Conveyor
- Ethernet Interface
- Haas Intuitive Programming System

¹ Standard on ST-40L



Haas Automation Europe | www.HaasCNC.com | +32 2 522 99 05 | Made in U.S.A.

Specifications subject to change without notice. Not responsible for typographical errors. Machines shown with optional equipment.

Haas ST-40 Series Lathes



The High-Performance Turning Centers

The Haas ST-40 Series high-performance turning centers provide heavy cutting ability, extreme rigidity, and high thermal stability. These large-capacity machines offer the best combination of performance and value in their class, and are available with a wide selection of high-productivity options, including high-torque live tooling and C axis. The long-bed ST-40L provides nearly double the cutting length for turning and boring long shafts and tubing.

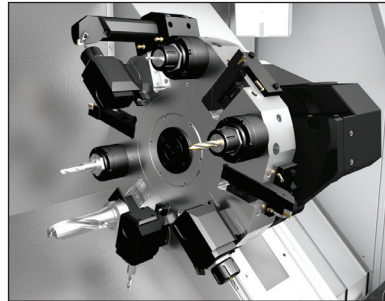
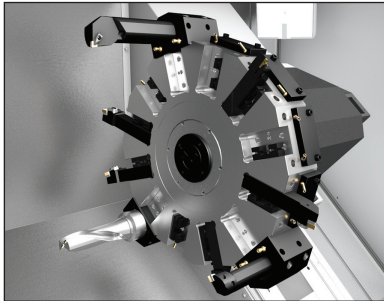

The ST-40 and ST-40L are equipped with a massive 12-station bolt-on style turret that accepts 31,75 mm stick tools, and is clamped hydraulically.

Both machines are also available with a 12-station VDI turret, or a 12-station hybrid turret that accepts both BOT tools and VDI tools, including driven tools.

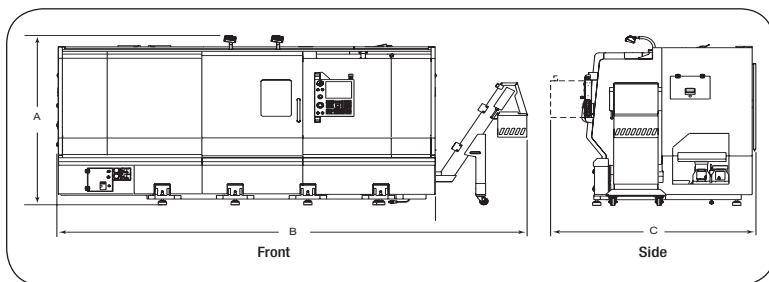

Operating Dimensions	ST-40	ST-40L
A. Max Operating Height	2261 mm	2261 mm
B. Max Operating Width w/conveyor	5817 mm	6655 mm
C. Max Operating Depth*	2616 mm	2616 mm

* Additional 914 mm required to open rear service panel.

[Specifications]

Capacities	ST-40	ST-40L
Chuck Size	381 mm	381 mm
Max Cutting Dia.	648 mm	648 mm
Max Cutting Length	1118 mm	2032 mm
Std. Bar Capacity	102 mm	102 mm

Spindle	ST-40	ST-40L
Max Speed	2400 rpm	2400 rpm
Max Motor Rating	29,8 kW	29,8 kW
Max Torque	1898 Nm @ 150 rpm	1898 Nm @ 150 rpm
Spindle Nose	A2-8	A2-8
Spindle Bore	Ø117,3 mm	Ø117,3 mm

Extra-Performance Spindle Option (with High-Torque Z-axis servo)	ST-40	ST-40L
Max Speed	2400 rpm	2400 rpm
Max Motor Rating	41 kW	41 kW
Max Torque	2847 Nm @ 150 rpm	2847 Nm @ 150 rpm
Z-Axis Max Thrust	30 025 N	30 025 N

Swing Diameter	ST-40	ST-40L
Over Front Apron	876 mm	876 mm
Over Cross Slide	648 mm	648 mm
Over Cross Tailstock	648 mm	648 mm

Travels & Feeds	ST-40	ST-40L
X Axis	432 mm	432 mm
Z Axis	1118 mm	2032 mm
X-Axis Max Thrust	24 465 N	24 465 N
Z-Axis Max Thrust	24 465 N	24 465 N
X-Axis Rapids	18,0 m/min	18,0 m/min
Z-Axis Rapids	18,0 m/min	8,1 m/min

General	ST-40	ST-40L
Power – 3-Phase	354 - 488 V	354 - 488 V
Weight	12 247 kg	13 068 kg



Specifications subject to change without notice.
Not responsible for typographical errors.
Machines shown with optional equipment.