

DI Series Displacement Transducers

FEATURES

- Large measuring range: Piston displacements from 50 to 1000 mm; 80 to 250 mm for DI 63X models
- Current-based output signal (4 to 20 mA) for displacement
- Built-in temperature measurement
- Very long life: No moving parts and therefore no wear of components (Eddy-current principle)
- Slim measuring system allowing large measuring range
- Insensitive to metallic impurities in the working fluid
- High shock and vibration resistance
- Capable of withstanding pressures up to 450 bar
- Robust construction, designed for permanent operation in hydraulic systems
- Standard temperature version, up to 80 °C (DI 5XX)
- High temperature versions, up to 125 °C (DI 60X and DI 61X) or up to 200 °C (DI 63X)
- EMC susceptibility conforms to European standards

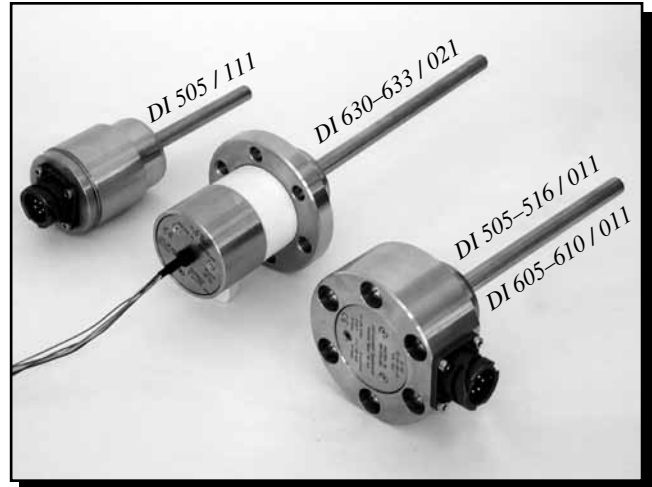

DESCRIPTION

Magtrol's line of Displacement Transducers provide contactless measurement of absolute piston position in hydraulic and pneumatic cylinders and other applications. Their robust construction, large insensitivity to shocks and very long life (due to no moving parts and therefore no wear of components) make them both cost effective and very reliable. Magtrol transducers offer a wide range of operational temperatures and admissible pressure resistance for even the most demanding applications.

The transducer provides a direct 4–20 mA output signal corresponding to the measuring range, as well as VDC temperature output. As an option Magtrol offers the CST 113 Signal Converter, which allows the complete chain to be calibrated according to the specific needs, either in current or voltage output.

APPLICATIONS

The DI series of displacement transducers were developed principally for OEM applications in the hydraulic industry. They enable the direct and reliable measurement of the position of:

- Hydraulic Cylinders
- Control Valves
- Servo Controls
- Steam Inlet Valves
- Propellers
- Stone Crushers

Their design is such that the installation cost is kept to a minimum. This cost-effectiveness results from the limitation to one fixed standard signal of 4 to 20 mA with very precise determination of the measurement interval (from 0 to full scale) on the sensing element.

BASIC CONFIGURATION

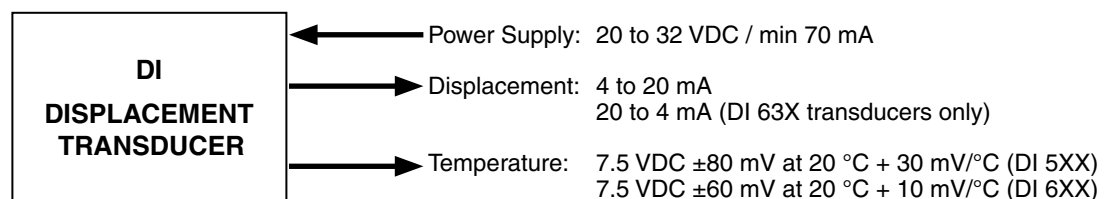

OPERATING PRINCIPLES

Eddy-Current Principle

Magtrol Displacement Transducers use the principle of Eddy-current measurement. An aluminum tube moves along the transducer's coil changing the induced Eddy-current losses, thus changing the coil impedance. An electronic circuitry housed in the transducer head, transforms the information of the measuring tube position into a linear signal. This circuitry uses modern SMD (surface-mounted device) technology, giving it robustness and reliability. The sensor is actively compensated for temperature changes.

Characteristics of the Output Signal

DI Series Displacement Transducers have a basic 3-wire configuration, providing a 4–20 mA current (20–4 mA for DI 63X transducers) proportional to the position of the aluminum tube. An indication of the temperature within the probe is also provided as a voltage output.

In closed-loop systems, a specific piston position can be repeatedly achieved with a precision better than 0.05% full scale (i.e. better than 50 μm for a measuring range of 1 m).

MODELS
DI 505–516 / 011
DI 605 / 011
DI 610 / 011

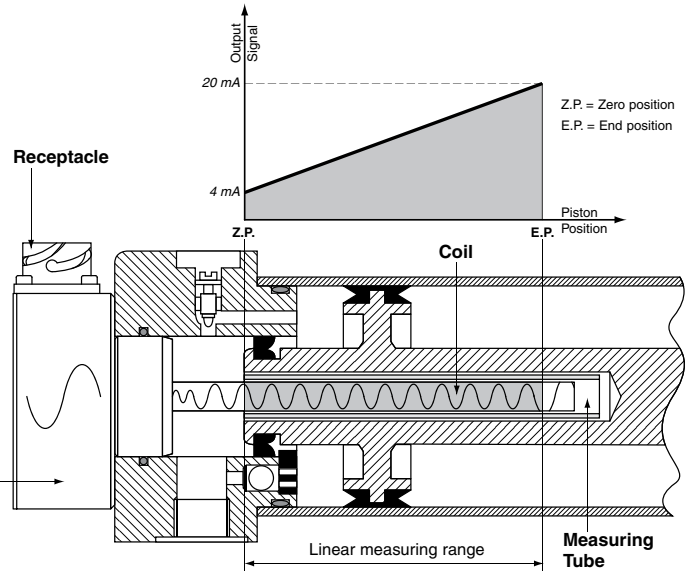

MODEL
DI 505 / 111

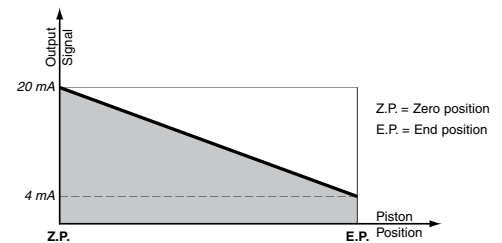
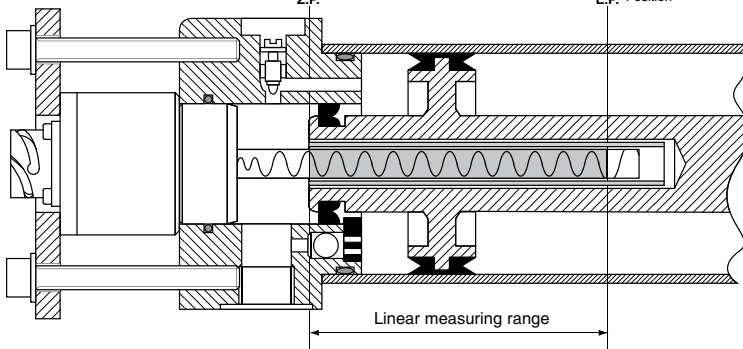
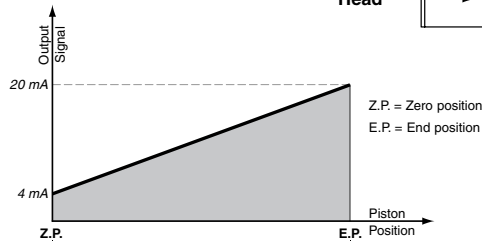

MODELS
DI 630–633 / 021

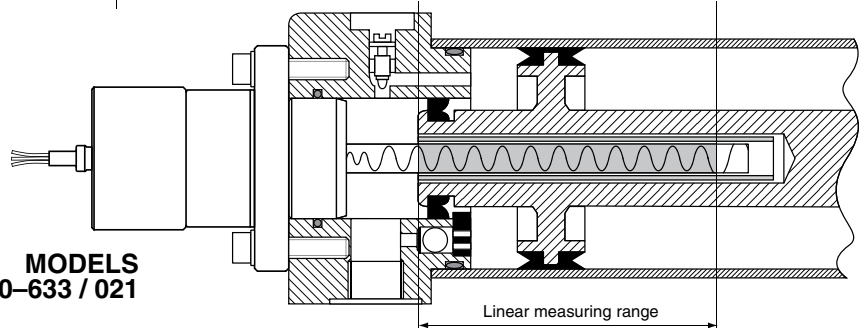

Version:	Standard Temperature		High Temperature	
Series:	DI 5XX		DI 60X and DI 61X	DI 63X
MEASUREMENT RANGES *				
Rated Values	50, 100, 160, 250, 300, 400, 630 and 1000 mm, according to dimension "D" on drawing		50, 100 and 160 mm, according to dimension "D" on drawing	80, 130, 200 and 250 mm, according to dimension "D" on drawing
Zero Position	Defined by inserting the transducer probe into the measurement tube as far as X_{min}			
Full-scale Position	Defined by inserting the transducer probe into the measurement tube as far as X_{max}			
OUTPUT SIGNAL **				
Displacement Output:	Current source with imposed 4 to 20 mA signal. The output current is independent of the load resistance, provided it remains within limits.			
<ul style="list-style-type: none"> • Zero • Full Scale • Admissible Load • Frequency Response 	Adjusted to 4 mA \pm 0.08 mA Adjusted to 20 mA \pm 0.15 mA 0 to 500 Ω 0 to 1000 Hz (-1 dB) with 4th-order Butterworth-type response		Adjusted to 20 mA \pm 0.08 mA Adjusted to 4 mA \pm 0.15 mA 0 to 500 Ω 0 to 820 Hz (-1 dB) with 4th-order Butterworth-type response	
Accuracy:	<ul style="list-style-type: none"> • Linearity Error • Resolution • Repeatability • White noise on output current 			
	0.5%, typically < 1% of FSD < 0.05% of FSD < 0.05% of FSD < 0.2 $\mu A_{eff} / \sqrt{Hz}$ (DC to 1 kHz)			
Temperature Influence:	<ul style="list-style-type: none"> • On Zero • On Sensitivity • On Drift (zero + sensitivity) 			
	< 150 ppm/ $^{\circ}C$ of FSD < 150 ppm/ $^{\circ}C$ of FSD < 1.5% of FSD over the entire operating temperature range			
Supply Voltage Influence:	<ul style="list-style-type: none"> • On Displacement Measurement • On Temperature Measurement 			
	< 10 ppm of FSD for 1 V variation (DC to 100 Hz) < 0.1 $^{\circ}C$ over the range 20 to 32 VDC			
Temperature Output:	<ul style="list-style-type: none"> • Offset Voltage • Temperature Signal • Output Resistance 			
	7.5 VDC \pm 80 mV at 20 $^{\circ}C$ 30 mV/ $^{\circ}C$, accuracy \pm 5% typically (\pm 10% max.) 1 k Ω	7.5 VDC \pm 60 mV at 20 $^{\circ}C$ 10 mV/ $^{\circ}C$, accuracy \pm 10% typically (\pm 20% max.) 1 k Ω	7.5 VDC \pm 60 mV at 20 $^{\circ}C$ 10 mV/ $^{\circ}C$, accuracy \pm 10% typically (\pm 15% max.) 1 k Ω	
POWER SUPPLY				
Supply Voltage	20 to 32 VDC			
Consumption	\leq 70 mA			
Connection	Watertight 5-pole bayonet connector; Watertight mating plug (straight or elbowed)		7 silicon wires: 0.09 mm ² length: 0.6 m	
Protection Against Polarity Inversion	No danger to the transducer in event of incorrect connection			
ENVIRONMENTAL				
Operating Temperature	-40 $^{\circ}C$ to +80 $^{\circ}C$	-40 $^{\circ}C$ to +125 $^{\circ}C$	Measuring Rod: -40 $^{\circ}C$ to +200 $^{\circ}C$ Electronics: -40 $^{\circ}C$ to +125 $^{\circ}C$	
Storage Temperature	-45 $^{\circ}C$ to +130 $^{\circ}C$			
Maximum Admissible Pressure	450 bar			
Admissible Shock	Half-sine, duration 3 ms, radial 100 g, axial 300 g			
Protection Class	IP 66, according to DIN 40050			
EMC	According to EN-50081-2 (Generic Emission Standard) and EN-50082-2 (Generic Immunity Standard)			

* Refer to drawings on pages 4 and 5.

** Calibrated standard signal. Transducer and measuring tube are calibrated in the factory for above-mentioned standard measuring ranges.

NOTE:

Original dimensions are in Metric units. All dimensions listed on this data sheet have been converted to English units, rounded up 2 or 3 decimal places.

MODELS DI 505-516/011 AND DI 605-610/011

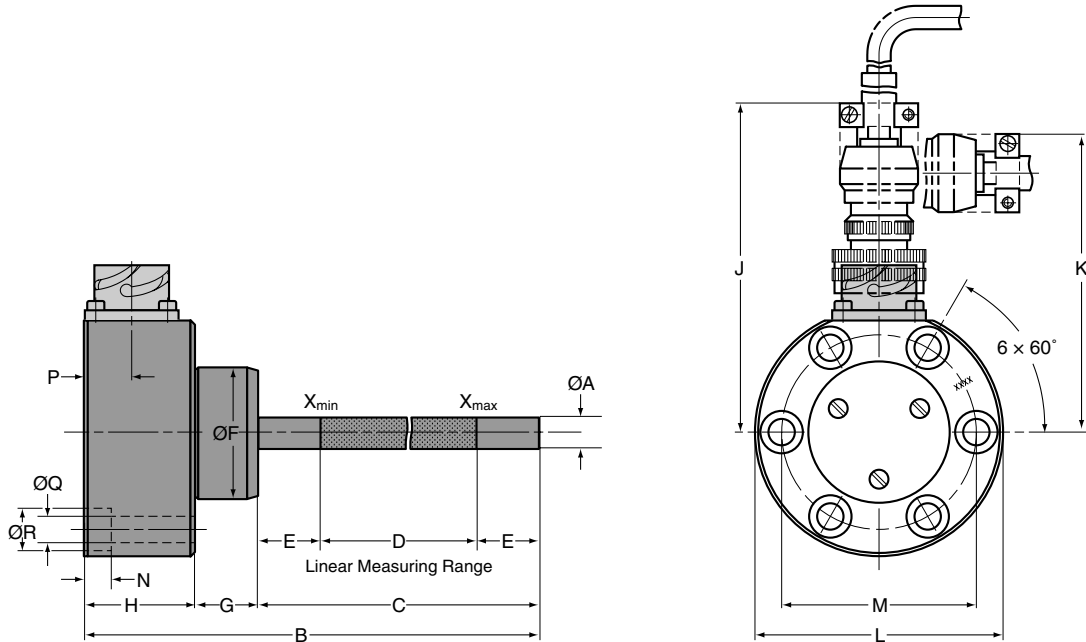

Model	units	ØA	B	C	D	E	ØF	G	H	J	K	L	M	N	P	ØQ	ØR	Weight
DI 505/011*	mm	10	145	90	50	20	42m6	20	35	≈105	≈95	79	62	8.5	15	8.4	13.5	1.15 kg
DI 605/011	in	0.39	5.71	3.54	1.97	0.79	1.6539/1.6545	0.79	1.38	4.13	3.74	3.11	2.44	0.335	0.59	0.33	0.53	2.54 lb
DI 510/011*	mm	10	195	140	100	20	42m6	20	35	≈105	≈95	79	62	8.5	15	8.4	13.5	1.25 kg
DI 610/011	in	0.39	7.68	5.51	3.94	0.79	1.6539/1.6545	0.79	1.38	4.13	3.74	3.11	2.44	0.335	0.59	0.33	0.53	2.76 lb
DI 511/011*	mm	10	255	200	160	20	42m6	20	35	≈105	≈95	79	62	8.5	15	8.4	13.5	1.30 kg
DI 611/011	in	0.39	10.04	7.87	6.30	0.79	1.6539/1.6545	0.79	1.38	4.13	3.74	3.11	2.44	0.335	0.59	0.33	0.53	2.87 lb
DI 512/011*	mm	10	345	290	250	20	42m6	20	35	≈105	≈95	79	62	8.5	15	8.4	13.5	1.40 kg
	in	0.39	13.58	11.41	9.84	0.79	1.6539/1.6545	0.79	1.38	4.13	3.74	3.11	2.44	0.335	0.59	0.33	0.53	3.09 lb
DI 513/011	mm	20	505	450	400	25	42m6	20	35	≈105	≈95	79	62	8.5	15	8.4	13.5	1.85 kg
	in	0.79	19.88	17.72	15.75	0.98	1.6539/1.6545	0.79	1.38	4.13	3.74	3.11	2.44	0.335	0.59	0.33	0.53	4.08 lb
DI 514/011	mm	20	735	680	630	25	42m6	20	35	≈105	≈95	79	62	8.5	15	8.4	13.5	2.20 kg
	in	0.79	28.94	26.77	24.80	0.98	1.6539/1.6545	0.79	1.38	4.13	3.74	3.11	2.44	0.335	0.59	0.33	0.53	4.86 lb
DI 515/011	mm	20	1105	1050	1000	25	42m6	20	35	≈105	≈95	79	62	8.5	15	8.4	13.5	2.60 kg
	in	0.79	43.50	41.33	39.37	0.98	1.6539/1.6545	0.79	1.38	4.13	3.74	3.11	2.44	0.335	0.59	0.33	0.53	5.73 lb
DI 516/011*	mm	10	395	340	300	20	42m6	20	35	≈105	≈95	79	62	8.5	15	8.4	13.5	1.70 kg
	in	0.39	15.55	13.39	11.81	0.79	1.6539/1.6545	0.79	1.38	4.13	3.74	3.11	2.44	0.335	0.59	0.33	0.53	3.75 lb

*These transducers are sometimes available with the same head as the DI 505/111 Please consult your Magtrol sales representative.

MODELS DI 630-633/021

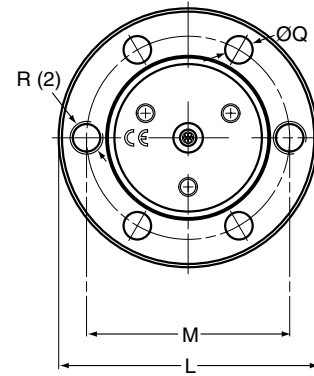
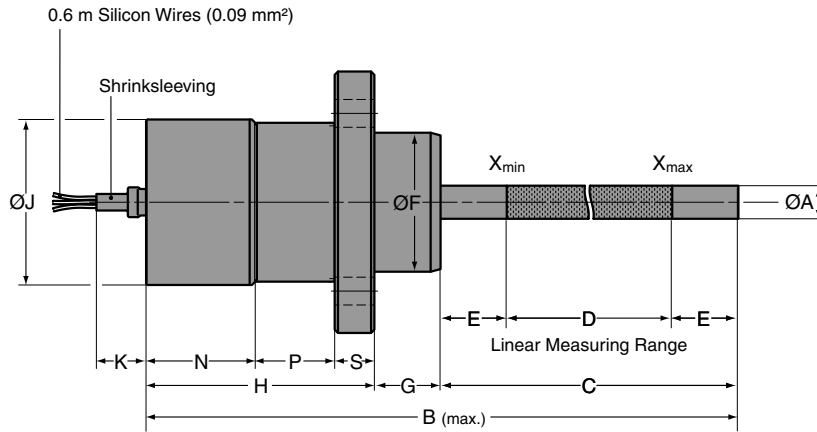

NOTE: The cover may have a $\pm 30^\circ$ angular position shift.

Model	units	ØA	B	C	D	E	ØF	G	H
DI 630/021	mm	10	209	120	80	20	42m6	20	69 ±0.05
	in	0.39	8.23	4.72	3.15	0.79	1.6539/1.6545	0.79	2.7146/2.7185
DI 631/021	mm	10	259	170	130	20	42m6	20	69 ±0.05
	in	0.39	10.20	6.69	5.12	0.79	1.6539/1.6545	0.79	2.7146/2.7185
DI 632/021	mm	10	329	240	200	20	42m6	20	69 ±0.05
	in	0.39	12.95	9.45	7.87	0.79	1.6539/1.6545	0.79	2.7146/2.7185
DI 633/021	mm	10	379	290	250	20	42m6	20	69 ±0.05
	in	0.39	14.92	11.42	9.84	0.79	1.6539/1.6545	0.79	2.7146/2.7185

Model	units	ØJ	K	ØL	M	N	P	ØQ	R	S	Weight
DI 630/021	mm	50	15	79	62	33	24	8.4	M10	12	1.0 kg
	in	1.97	0.59	3.11	2.44	1.30	0.94	0.33	---	0.47	2.20 lb
DI 631/021	mm	50	15	79	62	33	24	8.4	M10	12	1.2 kg
	in	1.97	0.59	3.11	2.44	1.30	0.94	0.33	---	0.47	2.65 lb
DI 632/021	mm	50	15	79	62	33	24	8.4	M10	12	1.5 kg
	in	1.97	0.59	3.11	2.44	1.30	0.94	0.33	---	0.47	3.31 lb
DI 633/021	mm	50	15	79	62	33	24	8.4	M10	12	1.7 kg
	in	1.97	0.59	3.11	2.44	1.30	0.94	0.33	---	0.47	3.75 lb

Note : The models DI 63x are also available with protection cover (see picture below) and 3 meter cable. Please contact Magtrol.





MODEL DI 505/111

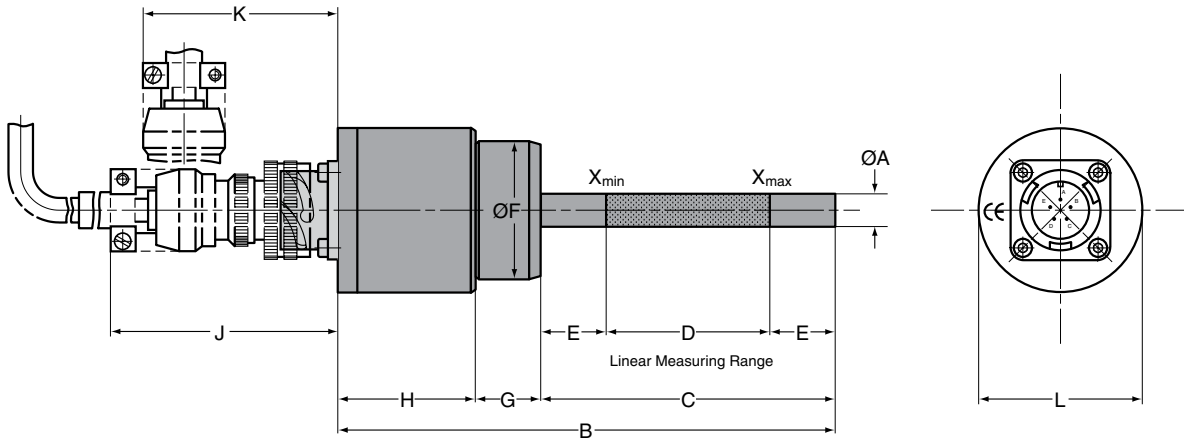

Model	units	ØA	B	C	D	E	ØF	G	H	J	K	L	Weight
DI 505/111	mm	10	153	90	50	20	42m6	20	43	70	60	50	1.1 kg
	in	0.39	6.02	3.54	1.97	0.79	1.6539/1.6545	0.79	1.69	2.76	2.36	1.97	2.43 lb

MODELS WITH THREADED HEAD M52 x 1.5

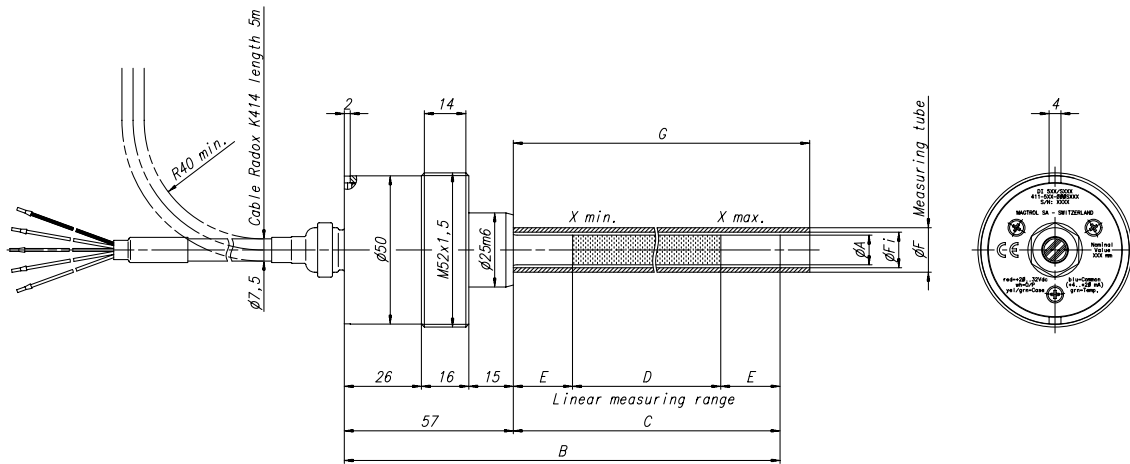

Model	units	ØA	B	C	D	E	ØF	ØFi	G
DI 510/S006	mm	10	197	140	100	20	15	12	150
	in	0.39	7.75	5.51	3.9	0.79	0.6	0.47	6
DI 511/S006	mm	10	257	200	160	20	15	12	210
	in	0.39	10.12	7.87	6.3	0.79	0.6	0.47	8.27
DI 512/S006	mm	10	347	290	250	20	15	12	300
	in	0.39	13.66	11.42	9.84	0.79	0.6	0.47	11.81
DI 516/S006	mm	10	397	340	300	20	15	12	350
	in	0.39	15.63	13.38	11.81	0.79	0.6	0.47	13.78

WIRING DIAGRAMS

DI 5XX, DI 60X and DI 61X Transducers

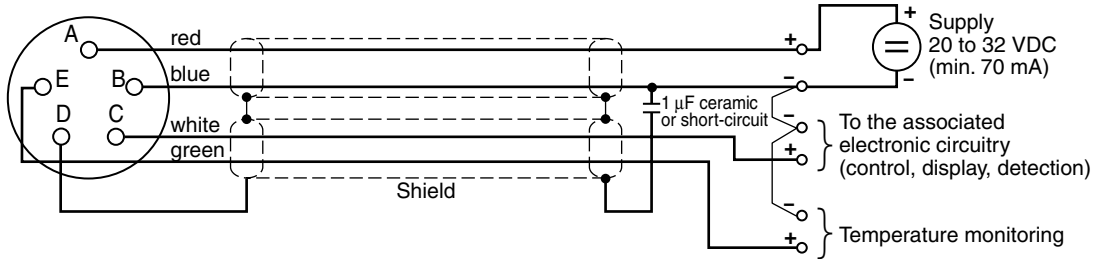

DI 63X Transducers

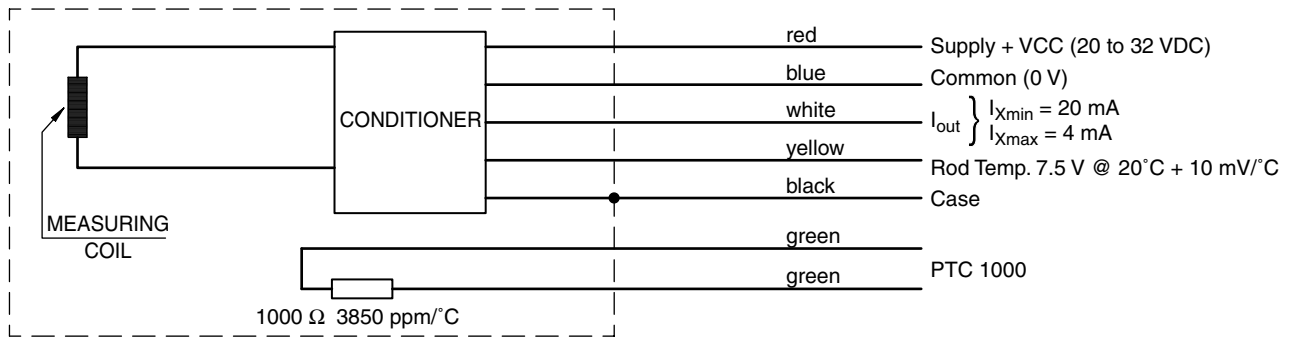

TUBE DIMENSIONS

Measurement Tube

Magtrol supplies the DI displacement transducer with the appropriate measurement tube, which is manufactured from EN AW-6060 T6 aluminum (Al Mg Si 0.5). This ensemble constitutes the calibrated system (4 to 20 mA; 20 to 4 mA for DI 63X).

Tube in Transducer Model	Outer Diameter		Inside Diameter		Length		Part Number*
	mm	in	mm	in	mm	in	
DI 505 / DI 605	13±0.15	0.5157/0.5079	11	0.43	100	3.94	411-505-021-011
DI 510 / DI 610	15±0.15	0.5945/0.5866	12	0.47	150	5.91	411-210-121-011
DI 511 / DI 611	15±0.15	0.5945/0.5866	12	0.47	210	8.27	411-211-121-011
DI 512 / DI 633	15±0.15	0.5945/0.5866	12	0.47	300	11.81	411-212-121-011
DI 513	26±0.20	1.0283/1.0189	22	0.87	460	18.11	411-213-122-011
DI 514	26±0.20	1.0283/1.0189	22	0.87	690	27.17	411-214-122-011
DI 515	28±0.20	1.1102/1.0945	24	0.94	1060	41.73	411-215-123-011
DI 516	15±0.15	0.5945/0.5866	12	0.47	350	13.78	411-216-121-011
DI 630	15±0.15	0.5945/0.5866	12	0.47	130	5.12	111-230-901-011
DI 631	15±0.15	0.5945/0.5866	12	0.47	175	6.89	111-231-901-011
DI 632	15±0.15	0.5945/0.5866	12	0.47	245	9.65	111-232-901-011

* Measuring tubes can be ordered separately, if needed, but are included with initial displacement transducer purchase.

OPTIONS AND ACCESSORIES

FOR MODELS DI 505–516 AND DI 605–611

5-Pole Mating Plug

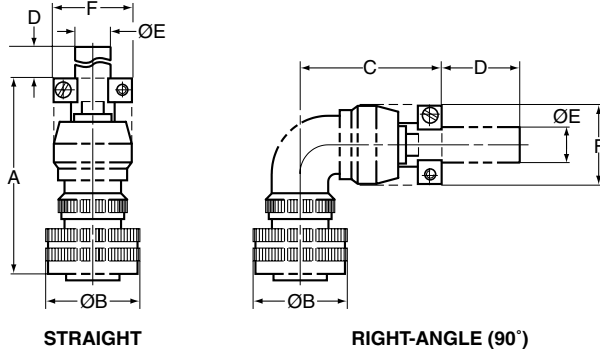

Plug Type	units	A	ØB	C	D	OE	F	Part Number
Straight	mm	≈65	30	---	≈25	11	25	957.11.08.0122
	in	2.56	1.18	---	0.98	0.43	0.98	
Right-angle	mm	---	30	≈45	≈25	11	25	957.11.08.0132
	in	---	1.18	1.77	0.98	0.43	0.98	

Accessory Ordering Information

4-Core Connection Cable: Model K-414

CONNECTION CABLE ASSEMBLY
(K-414 cable with 5-pole mating plug)

Part Number: EH 14 / 0 1

Mating Plug

- Straight _____ 4
- Right-Angle (90°) _____ 5

Cable Length

- 3 m _____ 1
- 5 m _____ 2
- 10 m _____ 3

SYSTEM OPTIONS

CST 113 Signal Converter

The CST 113 is a signal converter for transducers delivering a signal of 4 to 20 mA. Either a voltage-based signal (I/V conversion) or a current-based signal (I/I) can be chosen as the converter output, along with signal inversion if required. A wide variety of offset and gain values can be selected, matching many different applications. The use of micro switches (DIP switches) and potentiometers enable easy on-site adjustments and the independent settings make it possible to calibrate the CST 113 in one displacement, from the minimal to the maximum position of the jack.

A “transmission OK” output enables the electrical connection between the DI transducer and the CST 113 converter to be checked, thus allowing the system to be used in applications where safety is important. This operation is simply carried out

by measuring the current coming from the DI transducer. An anomaly is indicated by the opening of the output transistor.

The CST 113 power supply input features a galvanic separation to electrically isolate the power supply ground from the measuring chain ground. The CST 113 circuitry is available with either a plastic housing, for mounting on a DIN rail, or housed in aluminum IP 65.

Ordering Information

Description	Model
Signal Converter I/V and I/I:	
• with plastic housing	CST 113 / 011
• with aluminium IP 65 housing	CST 113 / 021

Due to the continual development of our products, we reserve the right to modify specifications without forewarning.



www.magtrol.com

MAGTROL INC
70 Gardenville Parkway
Buffalo, New York 14224 USA
Phone: +1 716 668 5555
Fax: +1 716 668 8705
E-mail: magtrol@magtrol.com

MAGTROL SA
Route de Montena 77
1728 Rossens/Fribourg, Switzerland
Phone: +41 (0)26 407 3000
Fax: +41 (0)26 407 3001
E-mail: magtrol@magtrol.ch

Subsidiaries in:
Germany • France
China • India
Worldwide Network
of Sales Agents

