

Technical Data Sheet TI-M11 Mechanical Valve Actuator MVA

Functional description is provided in "Technical Information TI-M10".

Further important practical advice is given in "Operating Manual BA-M11".

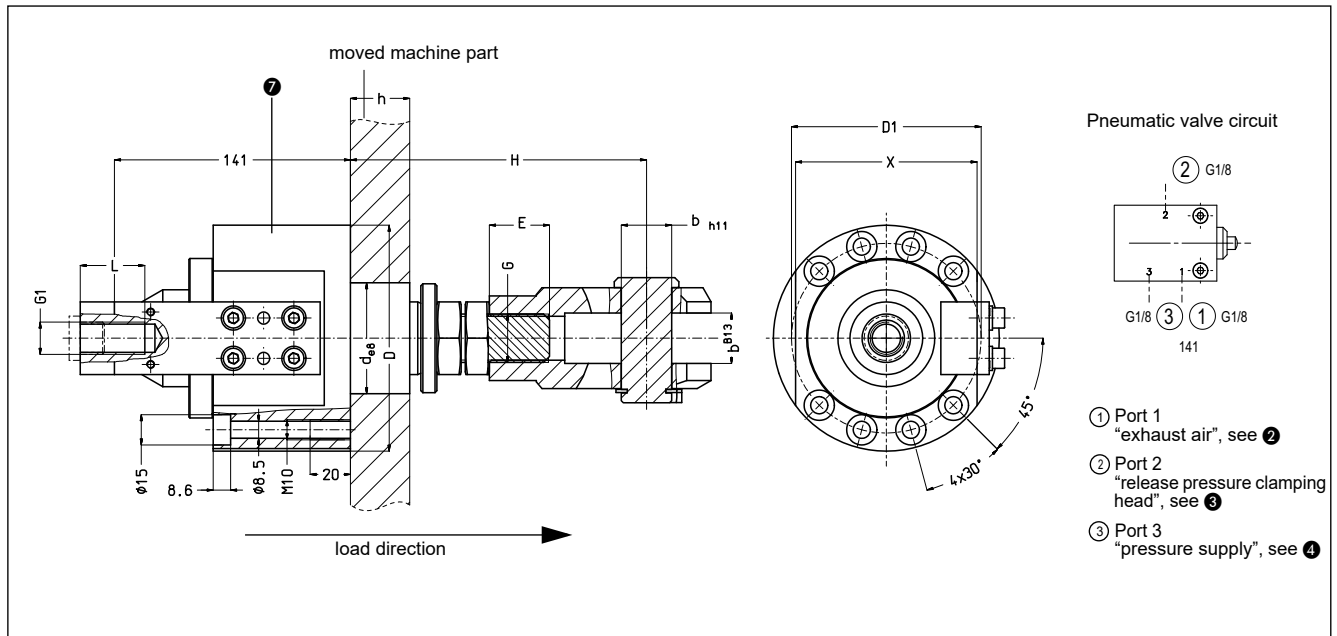

Fig. 1: Dimensions of Mechanical Valve Actuator MVA

Typ	Ident.-No.	¹ M	⁵ A	d	h	D	G	E	G1	L	H	b	X	D1	Wgt
	(order no.)	kN	kN	mm	mm	mm		mm		mm	mm	mm	mm	mm	kg
MVA 20	MVA 020 01	20	1	55	max. 40	112	M24x2	24	M16x1.5	32	179.5	25	90	94	8
MVA 35	MVA 035 01	35	1	62	max. 50	118	M30x2	30	M24x2	48	212.5	30	96	100	8.5

Subject to modification without prior notice

¹ M is the admissible load the mass to be secured exerts on the Mechanical Valve Actuator MVA. The acceleration of the load must not exceed 5 m/s². Overloading can cause breakage of the parts in the force of flow.

²³⁴ The pneumatic valve of the MVA switches pneumatic ports at operating pressures between 3.5 bar and 10 bar. The compressed air must be dried and filtered. SITEMA recommends using compressed air according to ISO 8573-1:2010 [7:4:4].

If the connection is relevant to safety, the assignment for pneumatic ports 1,2 and 3 is defined so that the safe state corresponds to the depressurized state (pneumatic valve not actuated).

If the connection is not relevant to safety, pneumatic ports 1, 2 and 3 can be assigned as required. Depending on the application, this allows the initial position (not actuated/actuated) to be defined as a closed or open.

⁵ A is the triggering force that actuates the pneumatic valve. To reach the "not actuated" state, the lifting force on the suspension element must exceed triggering force A. The tensioned suspension element then fully relieves the valve slider.

⁶ E is the minimum screw-in depth of the fork on the switch rod.

⁷ The surface of the housing parts is ZnNi coated.