

IP 20 tubular lights



Moisture-proof light
IP 40 or higher

CONCEPT

Shaft lighting system with different protection classes for new systems or retrofits. Tailored solutions that are quick and cost-effective to install:

- Mark out the first light/wall mounting plate
- Drill
- Dowel into place
- Insert cable
- Move on to next light
- ...all done

BENEFITS

- Quick installation of lights
- Quick laying of cables (no need for cable ducts, brackets, and so on)
- Easy-to-insert connecting cables
- Different all-in-one sets in accordance with IP 20, IP 40 or higher
- Components can be ordered individually

DETAILS

All-in-one sets for different shaft heights in accordance with IP 20, IP 40 or higher

Shaft lighting including illuminant, pluggable as
 – IP 20 tubular lights with a protective tube (21 Watt) or
 – IP 40 or higher moisture-proof lighting (36 Watt)
 with a full plastic cover

Feed cable from machine room to shaft lighting (10 m standard)

Pluggable connection cables (2 m standard) from light to light

OPTIONAL

- Pit control unit with, for example, emergency stop, light sensor, emergency call button and socket, fully wired
- Tailored connecting cables from the machine room switch cabinet to the pit control unit (10 m + height of shaft)
- Halogen-free versions available (not IP 20)



EMERGENCY STOP SWITCH

For example, emergency stop switch in casing in accordance with EN 81, 40 mm emergency stop switch, 1 NC, with change-over display in accordance with EN 81, released by turning or pulling. All with prepared cables in different lengths (for example, 5 m) and available in other designs.

EMERGENCY CALL BUTTON

For example, emergency call button in casing, for forwarding emergency calls, 40 mm yellow palm switch, 1 x NO, cage clamp, symbol: Emergency bell. All with prepared cables in different lengths (for example, 5 m) and available in other designs.

LIGHT SENSORS

Separate, with or without feed cable (different lengths available).

MACHINE ROOM STATION

For example, machine room station in casing with light sensor, shock-proof socket incl. light control (pulse relay) and acknowledgement light, with or without 10 m feed cable. Other cable lengths possible.

PIT CONTROL UNIT

4-function pit control unit with 40mm emergency stop switch, with viewing window, released by turning, 1 x NC, emergency call button, 1 x NO, light sensor, 1 x NO, and shockproof socket.

3-function pit control unit with 40mm emergency stop switch, with viewing window, released by turning, 1 x NC, light sensor, 1 x NO, and shockproof socket.

2-function pit control unit, light sensor 1 x NO, and shockproof socket.

All with prepared cables in different lengths and available in other designs (for example, with French/Belgian/Swiss sockets).

4-function pit control unit with 40mm emergency stop switch, with viewing window, released by turning, 1 x NC, emergency call button, 1 x NO, light sensor, 1 x NO, and shockproof socket, with prepared connection cable in different lengths and 5 m feed cable for monitoring tension weight.



CAR TOP INSPECTION STATION

For example, a 7-function service control unit (long casing), white travel button, 1 x NO, rotary selector switch (0 – 1 maintained contact switch), 3 x NC and 3 x NO, white button with arrow pointing up, 2 x NO, black pushbutton with arrow pointing down, 2 x NO, double light + alarm button, 1 x NO each, 40 mm emergency stop switch, 1 x NC, with change-over display, released by turning, shockproof socket, threading for M25 screw connection.

Other designs and pre-cabled versions available.



CAR TOP INSPECTION STATION

For example, 4-function retrieval control unit, 2 position rotary selector switch, 3 x NC, 3 x NO, up button, 1 x NC, 2 x NO, down button, 1 x NC, 2 x NO, emergency stop switch, 30 mm, with viewing window, released by turning, 2 x NC.

Other designs and pre-cabled versions available.



LIMIT SWITCH

For example, position switch, lever with roll, lever actuation, metal lever with rubber roll, D = 50, sliding contact, 2-pin, 1 x NC + 1 x NO.

Position switch with roller lever, adjustable, lever actuation, adjustable, metal lever with rubber roll, D = 50, snap contact, 2-pin, 1 x NC + 1 x NO.

For example position switch with roller lever, rubber roll and end position detent.

Other designs available.



MAIN SWITCH

Current carrying capacity from 25 to 100A, suitable for front, foot, and DIN guide rail assembly. Red handle, yellow contrast surface.

Versions with 2, 3, or 4 pins, central locking bolt and end-to-end shaft are available. The circuit breakers can be combined with 2- and 3-pin fuse holders (up to 32A).

Lockable, with or without casing, optional padlock.

ELEVATOR LIGHT CURTAIN 03.G5.B94

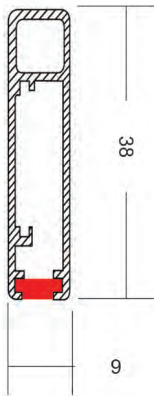

BENEFITS

- Slim 9 mm profile
- Very cost-effective

DETAILS

Crossed infra-red beams	94
Response time	< 40 ms
Active projection height (APH)	20 -1841 mm (EN81.70)
Detecting range	3000 mm (max. 5000 mm)
Ambient light	100,000 lux
Dimensions	9 mm x 38 mm x 2,000 mm
Supply voltage	24-48-60 VDC +/-15%, 230 VAC
Output (relay)	1 NO & 1 NC
Nudging / buzzer	on / off / timer
Separate power supply	1 NC / 1 NO
Operating temperature	-20° to 70° C
No auto masking	

OPTIONAL

- Universal fixing kit for various door types
- Auto masking function



Do you have questions about our products?
We're happy to help.
Phone: +49 (0) 71 34-34 38

ELEVATOR LIGHT CURTAIN 03.G5.S1X154

**BENEFITS**

- Ultra-slim 6.6 mm profile
- 32 diodes produce 154 beams
- Automatic learning (auto masking) - the light curtain recognises obstacles automatically and ignores them
- All in just three seconds
- Automatic stand-by mode. The light curtain puts itself in stand-by mode after 15 seconds to save energy and extend the service life of the sensors

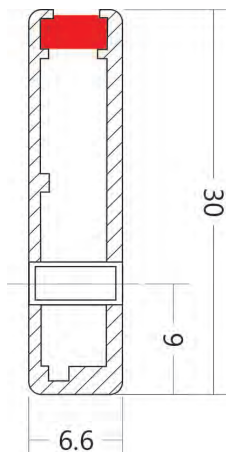
**DETAILS**

Beams	154
Diodes	32
Detecting range	0 - 4,000 mm
Operating conditions	Temperature: -20° to 65° C Ambient light: up to 100,000 lux IP 54
Tolerance	Vertical: +/- 20 mm (10°) Horizontal: +/- 3 mm (7°)
Dimensions	6.6 mm x 30 mm x 2,000 mm
Active projection height (APH)	20 - 1,841 mm
Auto masking zone	1,500 - 1,841 mm
Response time	69.2 ms
Power consumption	3 W
Output (relay)	Relay contacts: 1 NO & 1 NC
Green LED	System is ready
Red LED	Solid – beams are interrupted or system malfunction Blinking – Stand-by mode active Off – normal
Automatic stand-by mode	15 s after the door is fully closed
Supply voltage	10 – 20 VDC, 100 VDC, 110 VAC, 230 VAC

OPTIONAL

- Universal fixing kit for various door types

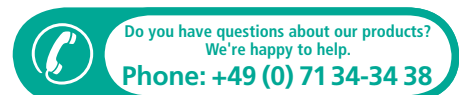

MAGNET HOLDER KITS for guide rails

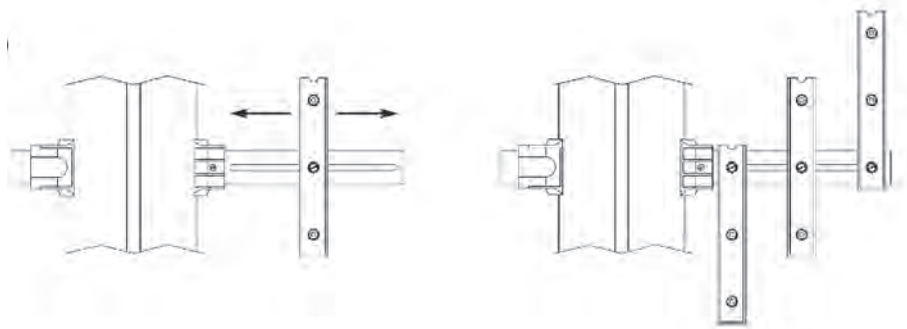

CONCEPT

A range of different modular attachment systems make it possible to place the magnets outside the guide rails. The magnet system can be attached to standard guide rails of different sizes. This makes it possible to install the magnets between two parallel guide rails.

