

# ELECTRIFICATION OF RTG CRANES



**MAKING PORTS MORE SUSTAINABLE  
WITH eRTG SOLUTIONS**

Up to 95 % savings in diesel fuel costs –  
the ECOLOGICAL solution

# BENEFITS OF GREENIFICATION

As one of the leading suppliers in the port industry, VAHLE represents the smartest solutions for greener ports. With our innovative and forward-looking product range we can be your strong partner to reach your ambitious goals. Providing you with our turnkey solutions, equipping your port with our upgrades or developing tailor-made solutions for future challenges is our passion.

The well-proven VAHLE eRTG solutions are especially developed and continuously improved for the current market demands like the requirements of decreasing your carbon footprint. Due to massive fuel savings you can competitively keep up with nowadays increased emission requirements. Furthermore it shows in an exemplary way your rising awareness for treating our environment with care.

## OPERATIONAL COSTS

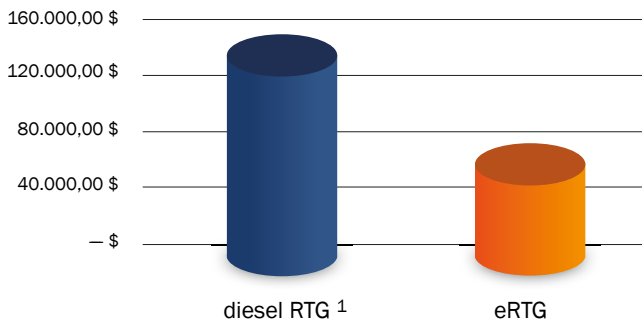

But it is not just about the ecological point, an economical as well:

We never forgot our common virtues: We know how the efficiency can be optimized while saving your money.

## CO<sub>2</sub> EMISSIONS

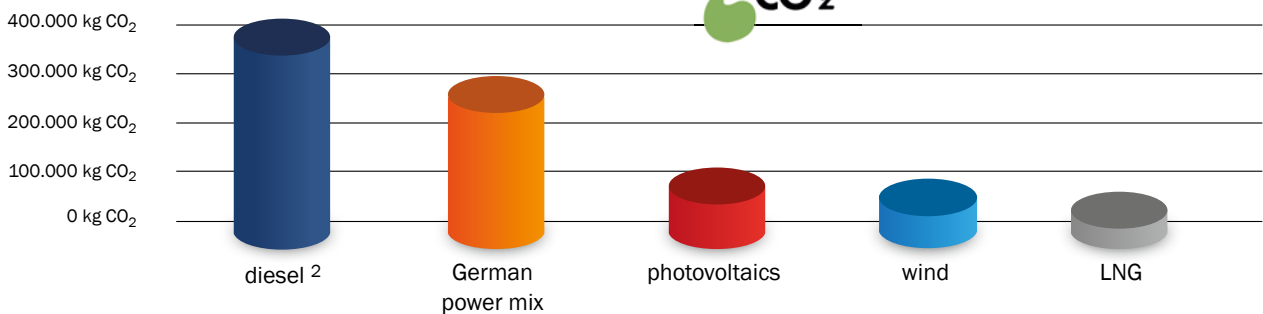

Lowering the carbon footprint of the RTG crane fleet significantly even with “normal” power mix. In combination with VAHLE energy storage technology sustainable energy can be used 24/7 and help for Greenification of your container terminal.

<sup>1</sup> Typical average savings

<sup>2</sup> 13l diesel engine / 12 hours operation time per day



There are two fundamental concepts for electrifying RTG cranes:

- Cable reel systems
- Conductor rail systems

Both concepts can be combined with VAHLE's energy storage technology to create hybrid or fully electrified RTG cranes.

The VAHLE telescopic arm with the current collector trolley is the intelligent way to save money.

Thanks to the automated entrance and exit procedure, the seamless switchover between grid and generator power supply, the autosteering system increases your efficiency and facilitates your day-to-day work.



The present innovation of a hybrid and fully electrified eRTG affects a new or a used RTG which gets converted with the telescopic arm but in spite of the standard solution the generator is not required. VAHLE adds or exchanges the generator against a powerful battery pack up to 120 kWh. A VAHLE converted completely electrified RTG contains the highest flexibility with the lowest emissions. Due to minimised diesel consumption and no longer necessary maintenance of the generator, it is currently the greenest and most cost-efficient way to run an RTG.



## STEEL SUPPORT STRUCTURE

The steel structure is the support frame for the conductor system and guides the current collector trolley. Currently there are two different setups for the conductor rails available. There is a so called 2+2 solution where two phases are arranged side by side and the third phase and the PE rail are arranged below them in parallel.

The other setup is the “4 in a row” arrangement. The three phases and the PE rail are arranged in parallel. Due to a bottom-up entrance the steel structure and conductor system could end flush with the containers without supernatant.

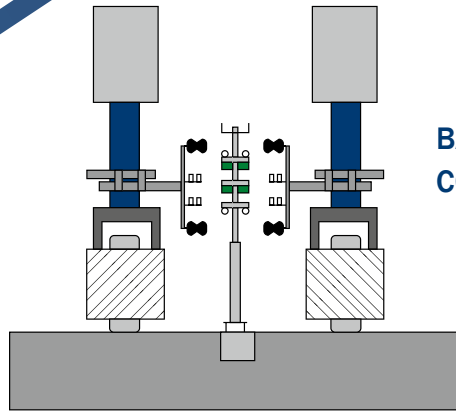

**BACK-TO-BACK  
CONNECTION ARRANGEMENT**

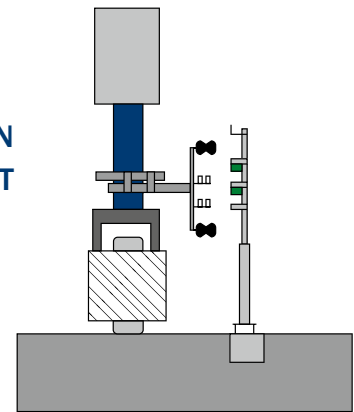

**SINGLE CONNECTION  
ARRANGEMENT**

## **ELECTRIC TELESCOPIC ARM AND CURRENT COLLECTOR TROLLEY FOR “2+2 ARRANGEMENT”**

One of the key components for the electrification is the telescopic arm with the current collector trolley attached at the arm. The arm is installed under the sill beam of the crane and provides the RTG with electric power through the conductor rails.

In order to cover typical requirements we offer three different telescopic arm lengths: 900 mm, 1300 mm and 1700 mm.

The vertical tolerance range is equal to  $\pm 200$  mm which enables the system to compensate unevennesses on the RTG runway.



# THE VAHLE TRIMOTION SYSTEM

The VAHLE Trimotion System - designed for four conductor rails in parallel - is a very compact solution for electrifying an RTG, also for limited spaces. With a maximum extension of 1700mm and two carbon brushes per phase it is VAHLE's newest development.

Three applications can be realised within one device: Electrification, Positioning and Data Communication.

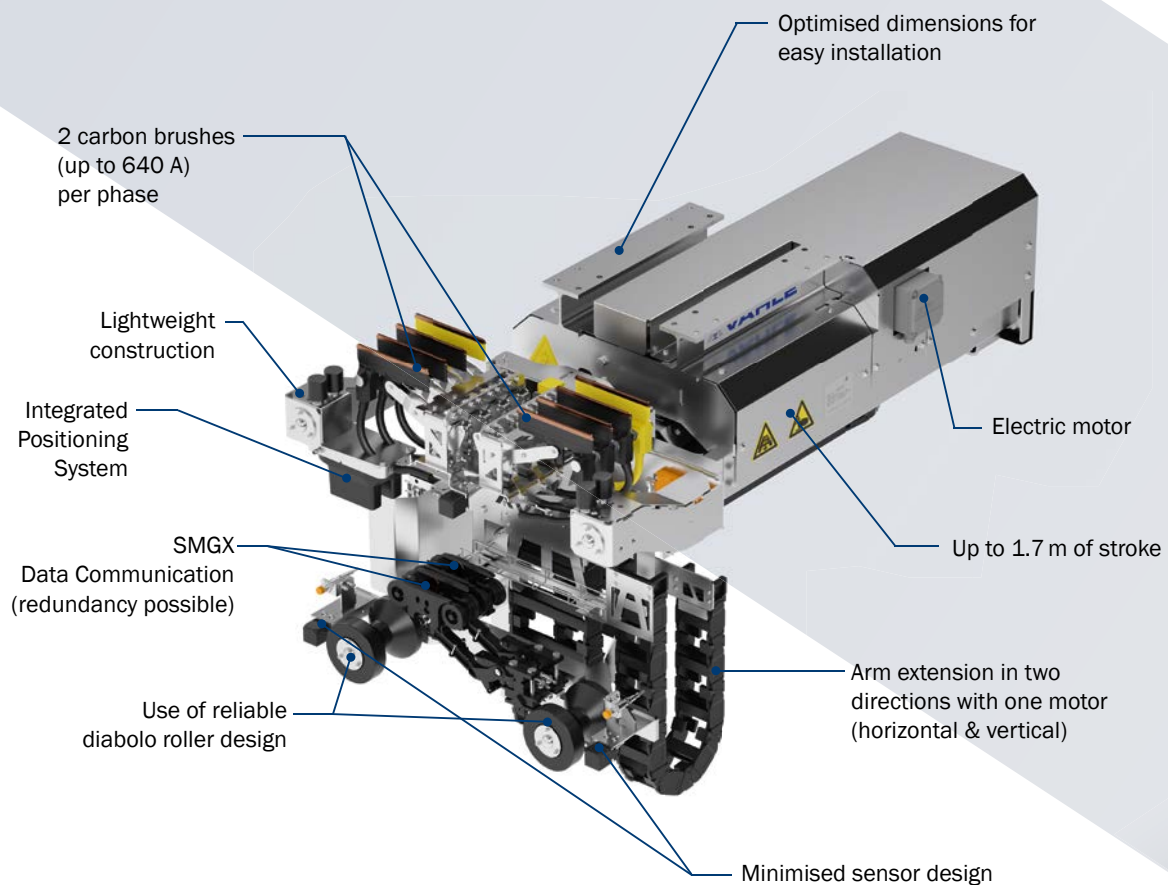

2<sup>nd</sup> step: lifting the trolley

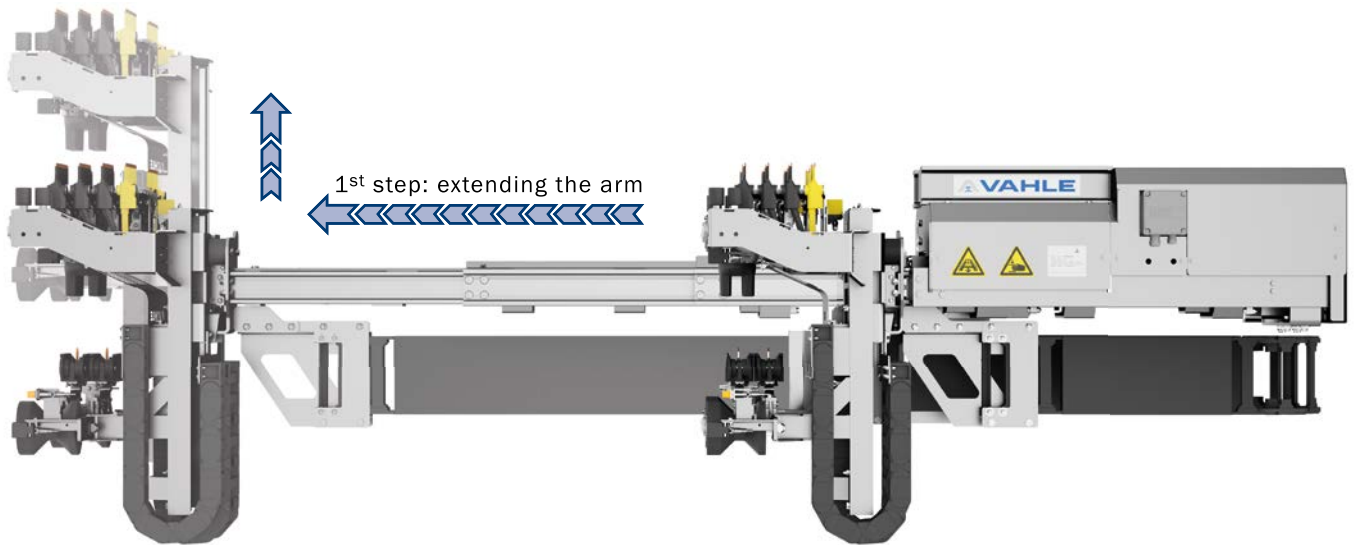

### MAIN ADVANTAGES:

- Lightweight construction allowing quick assembly
- One common design with 1700 mm extension covering all lengths
- One carbon brush capable for up to 320 A power transmission
- Easy subsequent integration of positioning and data communication systems
- Suitable for retrofit and new RTGs
- Modular design
- Driven by one motor only for vertical and horizontal movements
- Minimum of wearing parts
- High level of operational use

### ELECTRIFICATION + POSITIONING + DATA COMMUNICATION = AUTOMATION

Once you have implemented the TRIMOTION System ready for Automation you can operate the eRTGs in remote control, monitored via live video signal transmission and navigated from your control station including remote emergency stop.

## **HYBRID RTG - INCREASE YOUR SAVINGS**

The VAHLE hybrid RTG is electrified with the proven VAHLE equipment like the conductor rails, the telescopic arm and current collector trolley. Furthermore a battery pack is added to enable the RTG to change the container stack running under battery power. For moving over a longer distance the generator of the RTG supplies the required power.

## **FULLY ELECTRIFIED RTG - MAXIMISE YOUR SAVINGS**

The VAHLE fully electrified RTG is comparable to the hybrid RTG. Instead of a generator a battery pack up to 120 kWh is integrated in order to supply the RTG with electrical power for several hours independently from the grid. Cost-intensive maintenance works of the generator are no longer necessary and diesel consumption is minimised to zero.





# MAY WE INTRODUCE: THE INNOVATIVE TRIO FOR FUTURE DEMANDS

## **1<sup>st</sup> step:**

VAHLE's electrification system for minimisation of diesel consumption and reduction of the carbon footprint.

## **2<sup>nd</sup> step:**

VAHLE's positioning system for exact localisation of the RTG inside the container stack. The absolute positioning system is suitable for rough maritime environment and the next step for semi-automated and automated RTGs.

## **3<sup>rd</sup> step:**

VAHLE's data communication system for reliable, interference-free data transfer. The transmission of video and safe data with up to 100 Mbit/s allows remote operations.

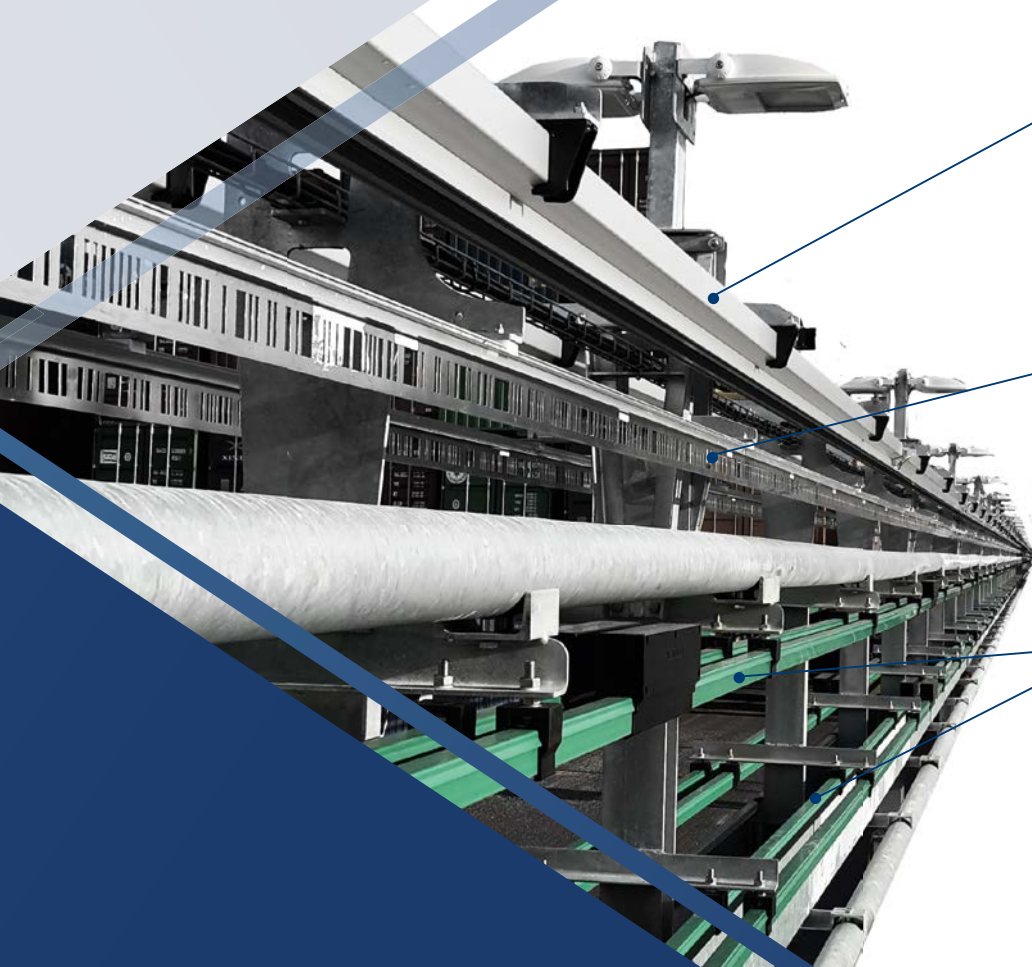

**SMGX  
Data Communication**

**Absolute  
positioning system**

**Conductor system  
power supply**

# TURNKEY SOLUTIONS



**CONSULTING**



**OPTIMISATION**



**ENGINEERING SOLUTION**

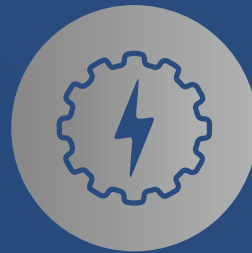

**MANUFACTURING**



# VAHLE

**Paul Vahle GmbH & Co. KG**

Westicker Str. 52

59174 Kamen

Germany

Tel.: +49 2307 704-0

Fax: +49 2307 704-444

[port-technology@vahle.de](mailto:port-technology@vahle.de)

[www.vahle.com](http://www.vahle.com)

