



# TECHNICAL DATA: SP 5008 HST

## THE 32 SERIES



	<b>5008</b>
<b>Chassis</b>	ACTIO™ – Full chassis with oscillation • Articulated • Hydrostatic transmission • 4 equal wheel drive
<b>Engine Type</b>	Direct-injection diesel - Emissions regulations: Stage 3A
N° Cylinders	4
Displacement (CC)	2190
Power kW/HP (97/68/CE)	34/46,2
Maximum engine revs	2700
Torque max (Nm/revs)	14,2/1620
Cooling	Water
Tank capacity (litres)	30
<b>Transmission</b>	Hydrostatic – Mechanical selector with 3 speed range: low/ normal/high – Stepless speed variator in both forward and reverse gears from 0 to 6 Km/h in the “low” range, from 0 to 12 Km/h in the “normal” range, from 0 to 30 Km/h in the “high” range with a “Speed-fix” selector for maintaining pre-set speeds
<b>PTO</b>	Front independent PTO with 2 speeds 540 and 1000 rpm
<b>Hydraulic Lift</b>	Double acting, with two-speed lift and descent, controlled by joystick - Capacity (Kg): 1100
Operating Pressure (bar)	150
<b>Steering</b>	Hydraulic power steering with 2 cylinders and Load Sensing system
<b>Brakes</b>	Service and parking brakes
<b>Tyres</b>	*240/70 R15 **6.50x16 ***29x12.50-15 Terra / Green / Xtra-Traction
<b>Weight (Kg)</b>	1470

### Dimensions

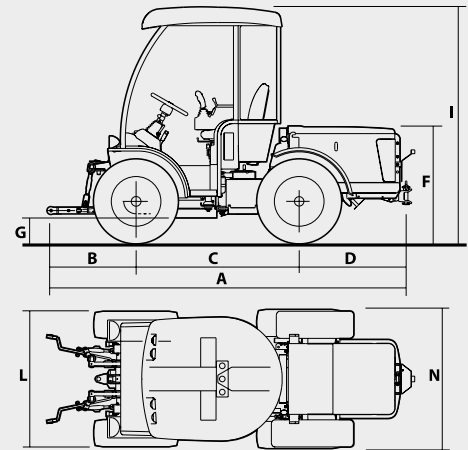

### SP 5008 HST

*	3075	718	1382	975	961	182	1964	1149	1180
**	3075	718	1382	975	990	211	1993	1116	1127
***	3075	718	1382	975	976	200	1982	1307	1321

### Standard features

Closed steel cab mounted on Silent-block, air conditioning with recirculation system, glass side doors, rear opening windows, system for the partial opening of the doors, green tinted rear windows, front windscreen wiper with 800 mm blade, 2 rear working lights, 2 rear view mirrors, 12V outlet, coat hook, glove compartments • Electrohydraulic inverter under the steering wheel • Pneumatically sprung comfort seat with head and armrests, safety belts, height adjustment, reclining back with lumbar adjustment • Front and rear differential lock • Tipping tray with sides, cm 95x90x20 • Disengaging drive wheels on front axle • Hydraulic system controlled by joystick, consisting of: 2 front double acting distributors with floating position, 1 rear replicated double acting distributor with floating position, 1 front oil reflow and 1 rear oil reflow (total 8 quick couplings) • Front/rear towing device • Horn, lighting equipment, electric power socket and plug, stop lights and turn signals • Digital multifunctional dashboard (tachometer/revolution counter, speed, fuel level, water temperature gauge) • Steering wheel adjustable in height and inclination • Safety starting switch on inverter, PTO and seat

### Optional extras

Hydraulic power lift engine side controlled by joystick • “Grammer” seat with pneumatic suspension • Hydraulic system consisting of: 2 front double acting distributors with floating position, 1 rear independent double acting distributor with floating position, 1 front oil reflow and 1 rear oil reflow (total 8 quick couplings) • Pair of front wheel ballasts • RT 1500 HDS – Front mounted rotating mower cm 150 with turbine • GRASS COLLECTOR GC1000 – Collector hopper with hydraulic discharge, load capacity lt 1000, discharge height cm 210

The description and illustrations in this brochure are provided simply for information purposes; they are not binding and may be varied at any time without notice.

**ANTONIO CARRARO SPA**

**Via Caltana, 24**

**35011 Campodarsego Padova ITALY**

**info@antoniocarraro.it**

**antoniocarraro.com**

**COD. 4 7318 134 - 06/2016**